

External alternator for ROTAX® Aircraft Engines

ATA System: 24-30-00 External alternator

1) Planning information

“PAC” Service Instruction Documents provide detailed information on non-certified ROTAX® Aircraft Engine Parts and Accessories. Referenced parts and accessories are provided without EASA certification or ASTM compliance. Certification / Compliance of referenced Parts and Accessories must be completed by the aircraft OEM.

To obtain satisfactory results, procedures specified in this publication must be accomplished with accepted methods in accordance with prevailing legal regulations.

BRP-Rotax GmbH & Co KG cannot accept any responsibility for the quality of work performed in accomplishing the requirements of this publication.

1.1) Applicability

Refer to the latest issue of the relevant Illustrated Parts Catalog.

NOTICE

The external alternator is not a part of the Engine Type Design. The external alternator has been tested and released by BRP-Rotax, but it is not certified.

The correct function in conjunction with the entire system and the certification of the external alternator is the responsibility of the aircraft manufacturer and must be carried out jointly with the aircraft.

1.2) Concurrent ASB/SB/SI and SL

None.

1.3) Reason

In the course of product maintenance and expansion of our spare parts program, external alternators sets are available.

An external alternator is not included in the scope of delivery for 915 i, 916 i Series aircraft engines. External alternator sets part no. 887259 (for 915 i Series) and part no. 887257 (for 916 i Series) are now available and include brackets for gearbox mounting.

1.4) Subject

External alternators for ROTAX® Aircraft Engines.

1.5) Compliance

NONE - For Information Only.

1.6) Approval

None.

1.7) Labor time and credit

Estimated labor hours:

Engine installed in the aircraft - - - labor time will depend on airframe installation and therefore no estimate is available from the engine manufacturer.

1.8) Mass data

Change of weight - - - see section 3.2).

SERVICE INSTRUCTION - PAC

1.9) Electrical load data

See Chapter 3.

1.10) Software modifications

No change.

1.11) References

In addition to this technical information refer to current issue of

- In general Illustrated Parts Catalog (IPC) and in particular Chapter 24-30-00.
- In general Installation Manual (IM) and in particular Chapter 24-00-00.
- In general Maintenance Manual Line (MML) and in particular Chapter 05-10-00 and 05-20-00.
- In general Maintenance Manual Heavy (MMH) and in particular Chapter 24-30-00.

NOTE: The status of the Manuals can be determined by checking the table of amendments. The 1st column of this table shows the revision status. Compare this number to that listed on the ROTAX website: www.flyrotax.com.

Updates and current revisions can be downloaded for free.

1.12) Other Publications affected

None.

1.13) Interchangeability of parts

All replacement parts within the same size are interchangeable without limitation with the current equivalent part of the same size. See also the requirements for installation and maintenance in Chapter 3.

SERVICE INSTRUCTION - PAC

2) Material Information

2.1) Material- cost and availability

Price and availability will be provided on request by ROTAX® Authorized Distributors or their independent Service Centers.

2.2) Company support information

- Any possible support by BRP-Rotax will be provided on request by ROTAX® Authorized Distributors or their independent Service Centers.

2.3) Material requirement and credit per engine

Parts requirement:

Fig.no.	Part no.	Qty/ engine	Description	Application
1	887259	1	Alternator set	915 i Series
2	887257	1	Alternator set	916 i Series

NOTE: Refer to the latest issue of the relevant Illustrated Parts Catalog.

2.4) Material requirement and credit per spare part

None.

2.5) Rework of parts

None.

2.6) Special tooling/lubricants- /adhesives- /sealing compounds

Price and availability will be supplied on request by ROTAX® Authorized Distributors or their independent Service Centers:

Fig.no	Part no.	Qty/ engine	Description	Application
1	-	1	Crimping pliers TE 58524-1*	Faston connector
2	-	1	Extractor tool TE 1-1579007-4*	Faston connector

* or equivalent

SERVICE INSTRUCTION - PAC

3) Accomplishment/Instructions

ROTAX® reserves the right to make any amendments to existing documents, which might become necessary due to this standardization, at the time of next revision or issue.

NOTE: Before maintenance, review the entire documentation to make sure you have a complete understanding of the procedure and requirements.

Accomplishment

All measures must be implemented and confirmed by at least one of the following persons or organizations:

- ROTAX® - Authorized Distributors or their independent Service Centers
- Persons with approved qualifications for the corresponding engine types. Only authorized persons (iRMT, Level Heavy Maintenance) are entitled to carry out this work

NOTE: Indicates supplementary information which may be needed to fully complete or understand an instruction.



All work has to be performed in accordance with the relevant ROTAX® Instructions for Continued Airworthiness (ICA) of the respective engine type.

General

Further material on general inspection, maintenance and repair can also be found in relevant Advisory Circular AC 43.13 from FAA.

Advisory Circular

The Advisory Circular (AC) contains maintenance methods, techniques and practices.

3.1) Illustrated Parts Catalog- related information

General



See current Illustrated Parts Catalog (IPC) for the respective engine type, Chapter 24-30-00.

3.2) Installation - related information

Optional extras

- External alternator (as option if the output of the integrated generator is inadequate).

SERVICE INSTRUCTION - PAC

3.2.1) Technical data

General note NOTE: The voltage regulator is integrated in the alternator.
Output Max. 550 W/DC at 6000 r.p.m. (complies ~ 4800 r.p.m. crankshaft speed).
Output voltage 14.2 V - 14.8 V.
Ambient temp. Ambient temperature range:

Min.	Max.
-30 °C (-22 °F)	+90 °C (194 °F)

Weight

Part no	Weight
887259	4,04 Kg (8,90 lbs)
887257	3,71 Kg (8,18 lbs)

3.2.2) Connections

See Fig 1.

Power supply wires Power supply wires to external alternator (1) have to be installed depending on the mounting position and according to the regulations of the aircraft manufacturer.
Positive terminal Positive terminal (2):
 M6 screw connection suitable for cable terminal according to DIN 46225 (tightening torque 4 Nm (35 in. lb)).
Ground Via engine block.
Control wiring Control wiring (3): Via supplied standard plug (Sumitomo 6111-2568) and 6.3x0.8 Faston connectors (female).

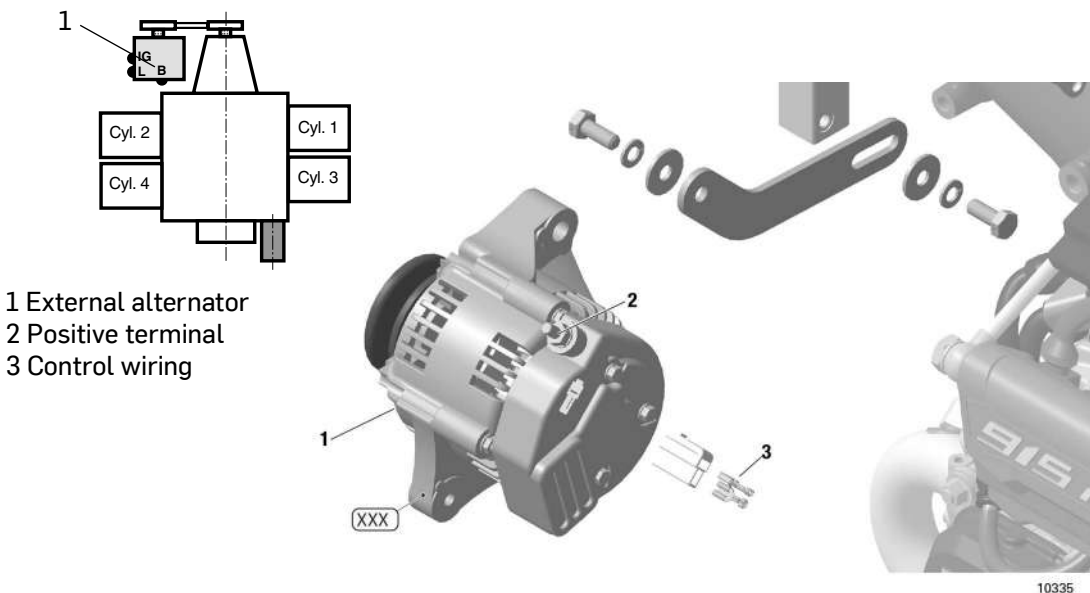

Fig. 1

d07173.fm

SERVICE INSTRUCTION - PAC

3.2.3) Requirements for correct operation of the integrated regulator

Fuse	The regulator must be protected by a slow blowing fuse or circuit breaker. Fuse or circuit breaker rating must be determined by load, wire size and length.
Load distribution	Due to slightly different output voltages of the regulators (alternator and regulator A/B of fuse box) the power is drawn by the generator with the higher output voltage at low load.
Amperage	

NOTICE

The current over engine speed graph was determined and is only effective under the following conditions.

- Ambient temperature: 20 °C (68 °F)
- Voltage: constant 13.5 V
- Tolerance: max. $\pm 5\%$

NOTE: The speed of the external alternator is 1.18 times the crankshaft speed or 3 times the propeller speed.

SERVICE INSTRUCTION - PAC

Wiring diagram See Fig. 2 and Fig. 3

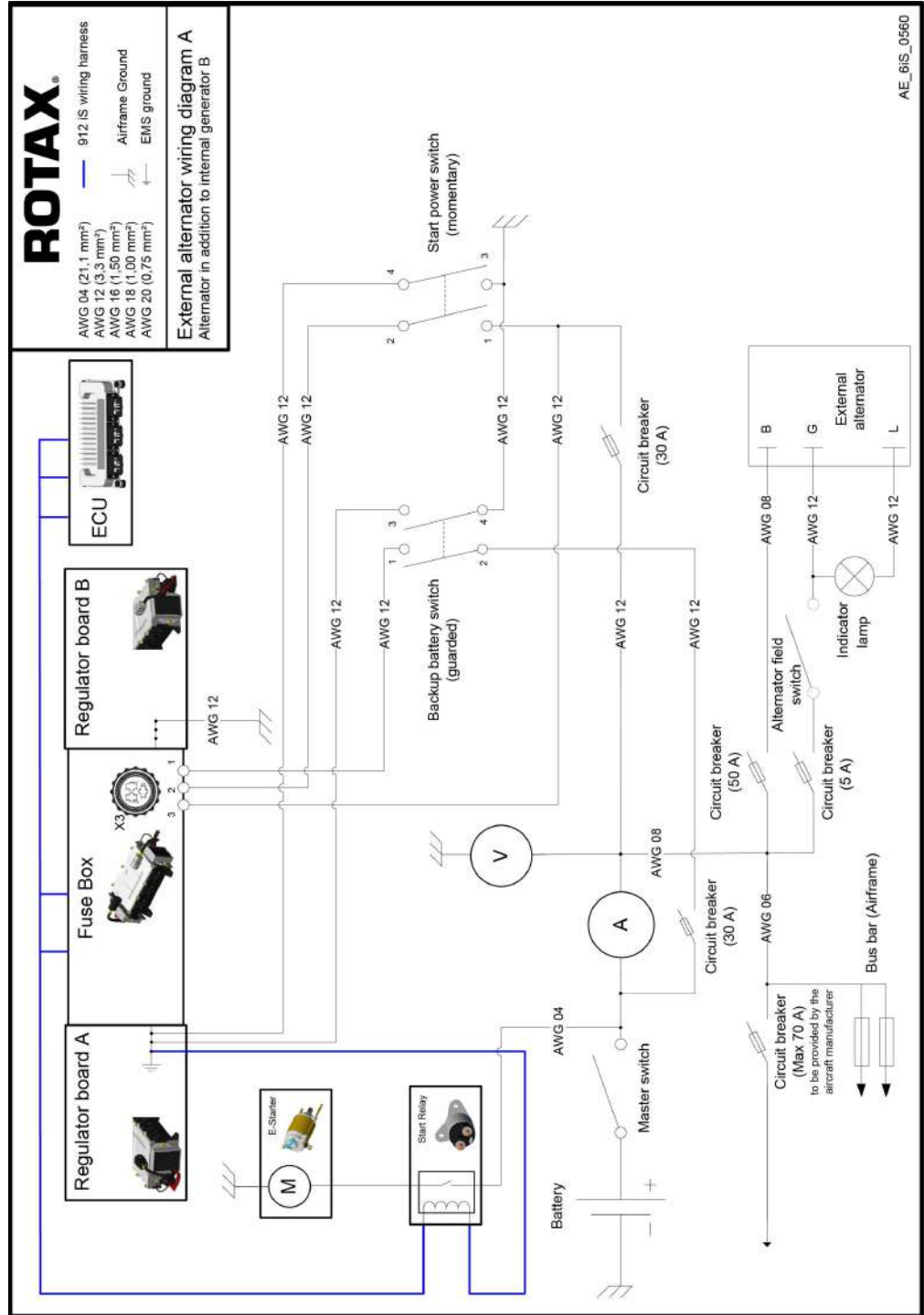

d07173.fm

Fig. 2.
External alternator Option A

SERVICE INSTRUCTION - PAC

3.3) Operation - related information

General The external alternator is a state-of-the-art, electromechanical three-phase generator (compact generator) with small outer dimensions. It has the task of supplying the electric consumers with energy and charging the starter battery with the least possible fuel consumption and low noise levels during operation of the aircraft.

Drive Drive is provided by the engine by means of a V-belt.

External alternator

Mechanical power consumption of the external alternator	
Max.	1200 W

Switch and warning lamp requirements

Switch The representation of components (such as switches, protection devices etc.) that are not included in the scope of engine delivery is purely symbolic. It does not constitute a specification of the version and shall therefore only be seen functionally. The actual interpretation / selection of the corresponding regulations is the task of the aircraft manufacturer.

EXTERNAL ALTERNATOR SWITCH	Requirement	Connector/slot
Switch type	Single Pole, Single Throw (SPST) switch	
Nominal voltage	28 VDC	
Nominal current	5 A	
Number of poles	1-pole	
Designation on wiring harness	Not connected to the engine wiring harness	

Warning lamps

EXTERNAL ALTERNATOR INDICATOR LAMP	Requirement	Connector/slot
Lamp colour	In accordance with the regulations	
Nominal voltage	12 V	
Nominal current	Maximum 300 mA	
Designation on wiring harness	Not connected to the engine wiring harness	

SERVICE INSTRUCTION - PAC

3.4) Maintenance (Line) - related information

3.4.1) Checking the V-belt tension

See Fig. 4

General note In the case of configurations with additional external alternator, inspect attachment and V-belt tension.

Checking the V-belt tension Inspect V-belt tension as per drawing below.

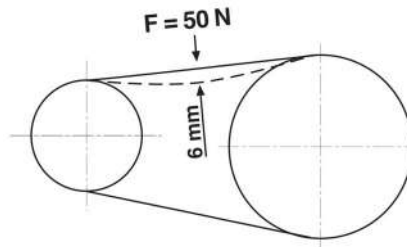

Fig. 4

3.4.2) Adjust the V-belt tension

See Fig. 5

Belt tension To adjust the belt tension:

Step	Procedure
1	Loosen the hex. screw M10 (1) and the 2 Allen screw M8 (2 and (3)).
2	Press the alternator upwards and tighten Allen screw (3).
3	Then tighten Hex. screw M10 (1) with tightening torque 40 NM (30 ft.lb) and Allen screw M8 (2) with tightening torque 22 Nm (195 in.lb).

- 1 Hex. screw M10
- 2 Allen screw M8
- 3 Allen screw M8

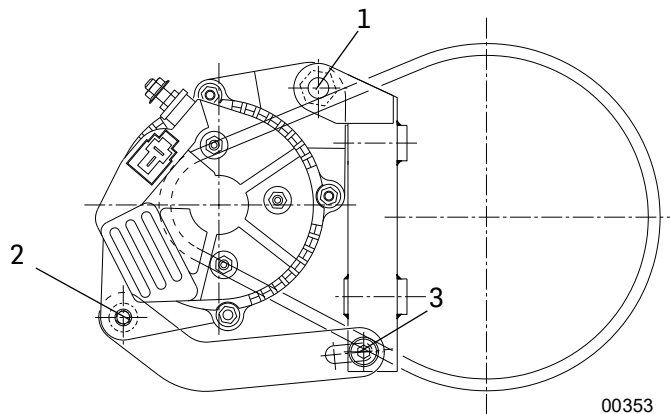

Fig. 5

NOTICE

Deflection of the V-belt must not exceed 6 mm (1/4") with a load of 50 N (11 lb) at center.

d07173.fm

SERVICE INSTRUCTION - PAC

3.5) Maintenance (Heavy) - related information

Safety information



Danger of damage to engine!
 There is a risk of short circuits and cable fires during work on the electric system. All installation work on the electric system should be carried out with the engine switched "OFF" and the battery (negative terminal) disconnected.
 Ignition, main and Lane selector switches must be "OFF".

3.5.1) Preparation

- Loosen pulley tension
- Remove the propeller. See "Documentation of aircraft manufacturer".

3.5.2) V-Belt pulley-removal

See [Fig. 6](#).

Step	Procedure
1	Loosen 8 Allen screws M5x16 with lock washers.
2	Remove pulley carries, V-belt pulley and V-belt.

- 1 Allen screw M5x16
- 2 Lock washer A5
- 3 Pulley carries
- 4 V-belt pulley
- 5 V-belt

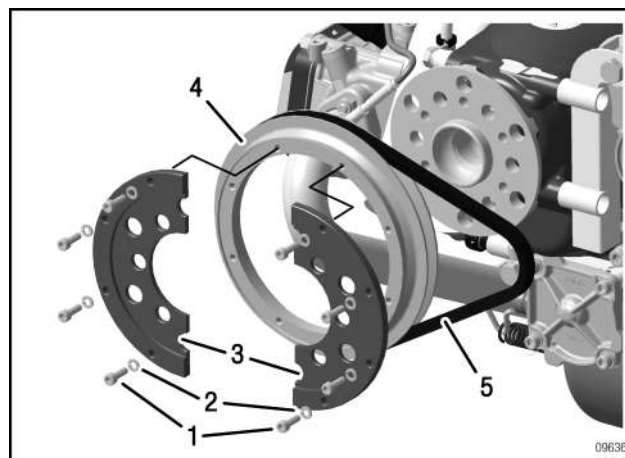

Fig. 6

d07173.fm

SERVICE INSTRUCTION - PAC

3.5.3) Alternator - removal

See Fig. 7 to Fig. 10.

Step	Procedure
1	Loosen 2 hex. screws M8x20 along with lock washers and washers.
2	Remove the tension bar underneath the external alternator.

- 1 Hex. screws M8x20
- 2 Lock washer A8
- 3 Washer 8.4
- 4 Tension bar

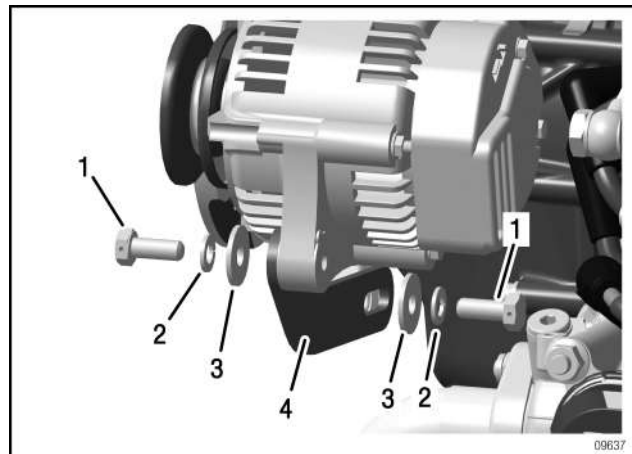

Fig. 7

3	Loosen hex. screw M10x45 and remove the alternator and thrust washer.
---	---

- 1 Hex. screws M10x45
- 2 Thrust washer 10.1/20/0.5
- 3 External alternator

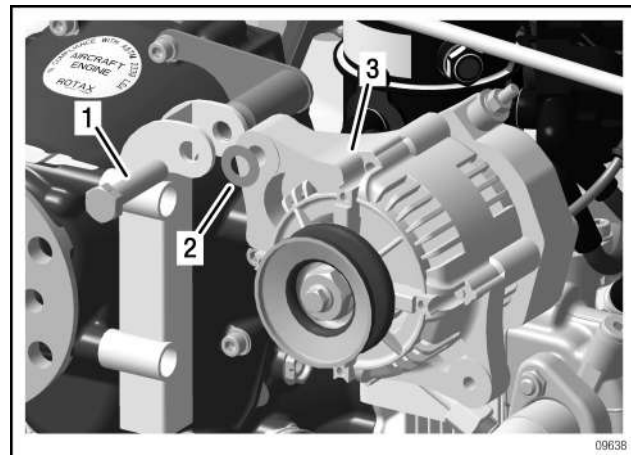

Fig. 8

d07173.fm

SERVICE INSTRUCTION - PAC

Step	Procedure
4	Loosen Allen screws M8x20 along with lock washers and remove the alternator bracket.

- 1 Alternator bracket assy.
- 2 Lock washer VHZ 8
- 3 Allen screw M8x20

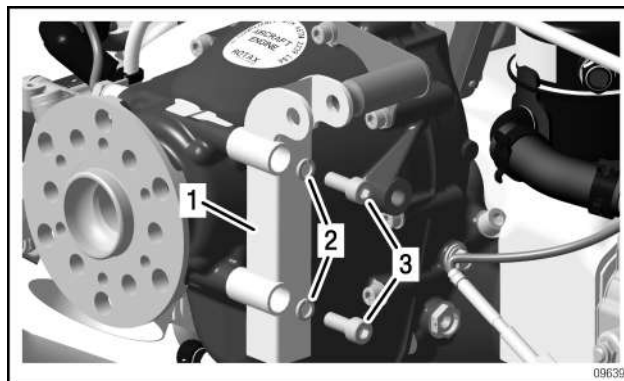

Fig. 9

Step	Procedure
5	Remove 2 Allen screws M6x50 along with lock washers and washers from the gear-box housing and alternator support assy.

- 1 Alternator support assy.
- 2 Lock washer A6
- 3 Allen screw M6x50

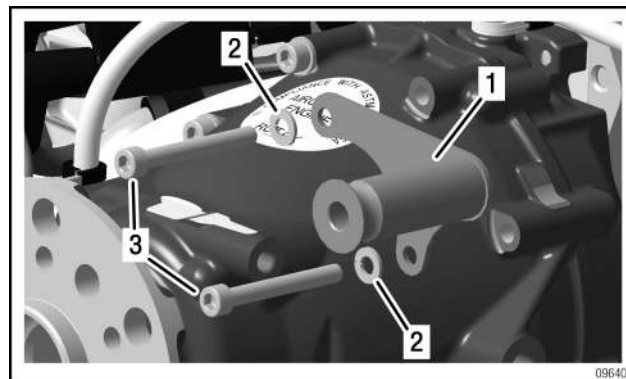

Fig. 10

d07173.fm

SERVICE INSTRUCTION - PAC

3.5.4) Fitting of the V-belt

See Fig. 11.

Step	Procedure
1	Clean and inspect propeller flange.
2	Place V-belt pulley completely over propeller flange and insert the 9.5x675 V-belt loosely into the V-belt pulley.

- 1 V-belt pulley
- 2 V-belt 9.5x675
- 3 Propeller flange

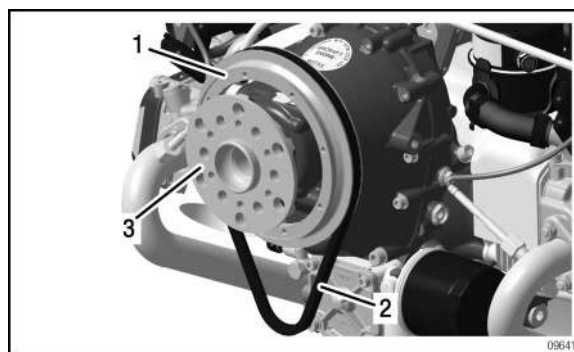

Fig. 11

NOTICE

The two pulley carriers must sit with the centring exactly on the inner side of the propeller flange.

See Fig. 12.

Step	Procedure
2	Insert both pulley carriers with the centring towards the inner side of the propeller flange.
3	Push the V-belt pulley onto the two pulley carriers and tighten with 8 Allen screws M5x16 and lock washers. Tightening torque 6 Nm (53.09 in. lb).

- 1 Allen screws M5x16
- 2 Lock washer M5
- 3 Pulley carrier

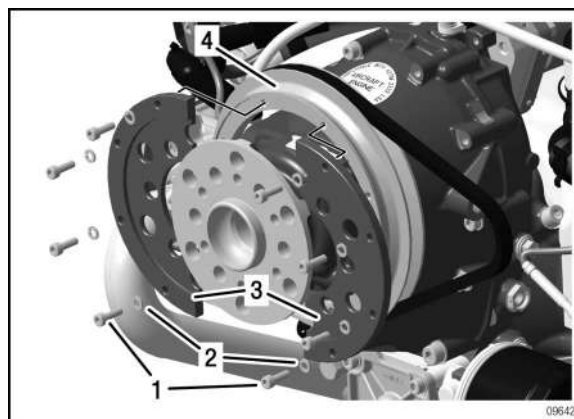

Fig. 12

d07173.fm

SERVICE INSTRUCTION - PAC

3.5.5) Installation of the alternator

See Fig. 13 to Fig. 17.

Step	Procedure
1	Fix the alternator support finger-tight by means of 2 Allen screws M6x50 and lock washers.

- 1 Alternator support assy.
- 2 Lock washer A6
- 3 Allen screws M6x50

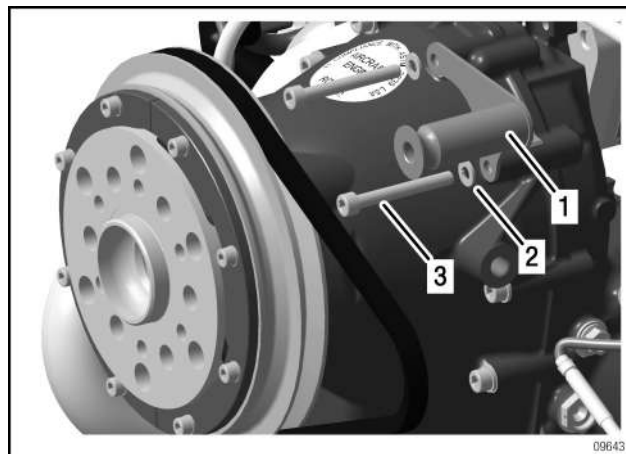

Fig. 13

Step	Procedure
2	Attach the alternator bracket finger-tight to the gearbox housing using the 2 Allen screws M8x20 and lock washers VHZ 8.

- 1 Alternator bracket assy.
- 2 Allen screws M8x20
- 3 Lock washers VHZ 8

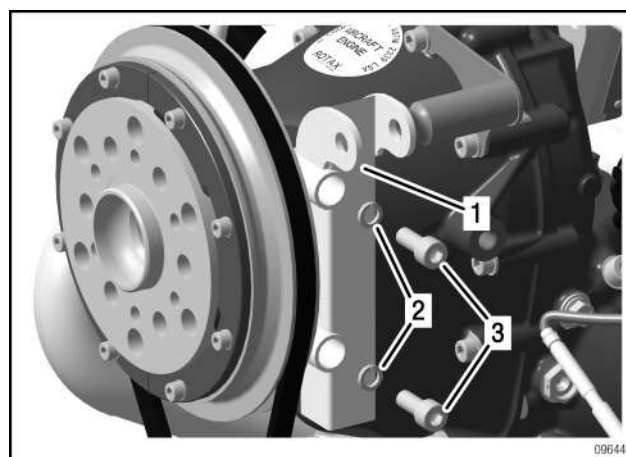

Fig. 14

d07173.fm

SERVICE INSTRUCTION - PAC

Step	Procedure
3	Push the alternator into the lug of the alternator bracket and fix initially finger-tight with hex. screws M10x45 and thrust washer 10.1/20/0.5.

- 1 Alternator
- 2 Washer 10.1/20/0.5
- 3 Hex. screw M10x45

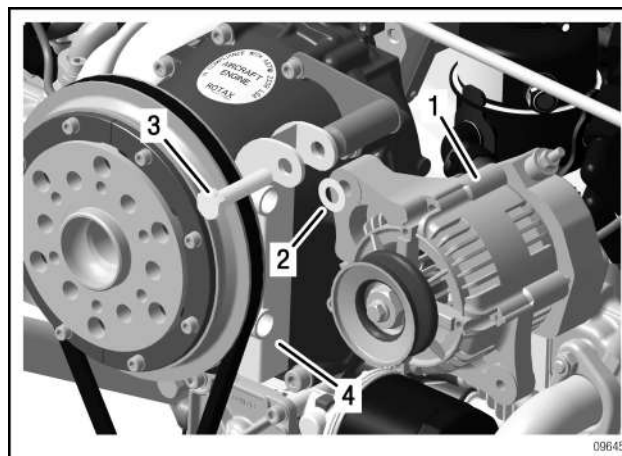

Fig. 15

Step	Procedure
4	Tighten the pre-mounted Allen screws M6 and M8. Tightening torque 10 Nm (89 in. lb).
5	Place the V-belt in the V-belt pulley of the alternator.

- 1 V-belt 9.5x675
- 2 Allen screw M8x20
- 3 Allen screws M6x50

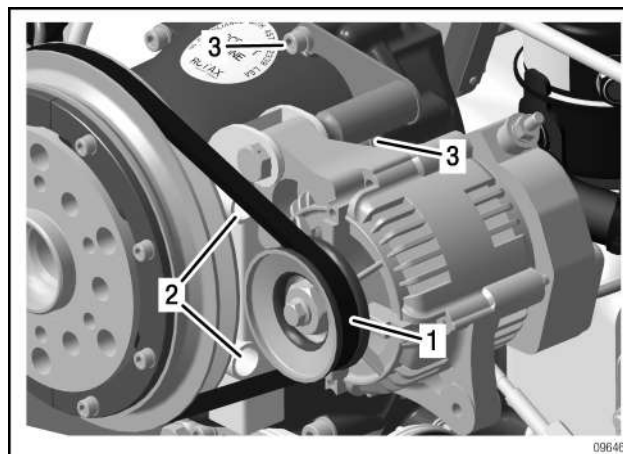

Fig. 16

d07173.fm

SERVICE INSTRUCTION - PAC

Step	Procedure
6	Attach the tension bar finger-tight to the alternator bracket using 2 hex. screws M8x20 with a lock washer and a washer.

- 1 Hex. screws M8x20
- 2 Lock washer A8
- 3 Washer 8.4
- 4 Tension bar

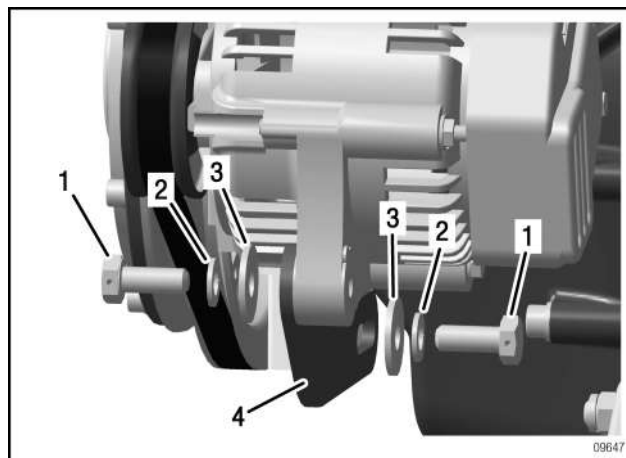

Fig. 17

Step	Procedure
7	Adjust the pulley tension and tighten M10 and M8 hex. screws with safety wire. Tightening torque M10: 40 Nm (354 in.lb). Tightening torque M8: 22 Nm (194.7 in.lb).

3.5.6) V-belt tension



See Chapter [3.4.2](#)) Adjust the V-belt tension.

SERVICE INSTRUCTION - PAC

3.6) Connecting the external alternator into the electric circuit

There are two options for connection of the external alternator:

OPTION A: Connection to main switch at battery.

See [Fig. 18](#)

Step	OPTION A - Procedure
1	Connect alternator terminal "B" to the main switch at the battery with a flexible multi-strand wire with proper cross-section according to the requirements in the relevant aircraft installation and a 50 A fuse.
2	Connect terminals "IG" and "L" into the circuit in accordance with the wiring diagram (Fig. 2) using connectors and housing provided.

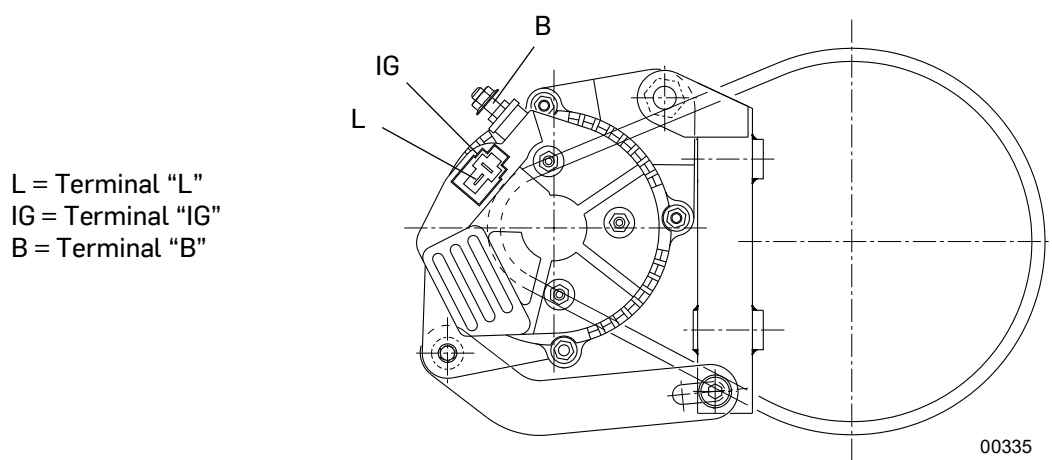

Fig. 18

SERVICE INSTRUCTION - PAC

OPTION B: Connection as replacement of generator B and regulator B.
See [Fig. 19](#).

Step	OPTION B - Procedure
1	Dis-connect the generator connector (1) from regulator B (2)

- 1 Generator connector
- 2 Regulator B connector



AE_6IS_0556

Fig. 19

See [Fig. 20](#) and [Fig. 21](#).

Step	OPTION B - Procedure
2	Insert amphenol plug (1) into open connector on regulator and amphenol plug into the open Generator B connector (2). NOTE: Use part no. 481510 Connector Set Stator Generator B or equivalent.
3	Connect alternator terminal "B" to pin 2 (1) of the fusebox "X3" connector Fig. 3 . NOTE: See current SI-PAC-012 Connector set airframe side (HICX3) for ROTAX Aircraft Engines.
4	Ensure that ground stud (2) for regulator B is connected to airframe ground with flexible multi-strand wire of min. 4 mm ² cross section (12 AWG).

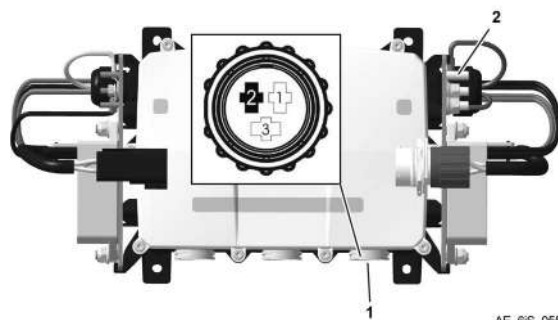

AE_6IS_0557

- 1 Pin 2
- 2 Ground stud

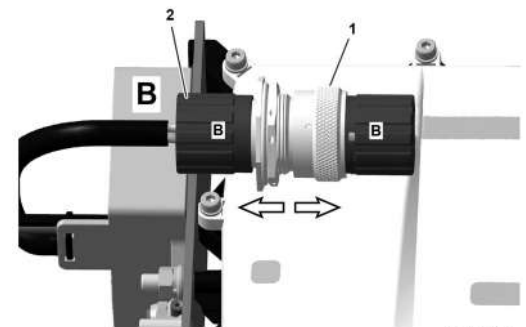

AE_6IS_0554

- 1 Amphenol connector Regulator B
- 2 Regulator B connector

Fig. 20

d07173.fm

SERVICE INSTRUCTION - PAC

Step	OPTION B - Procedure
5	Connect terminals "IG" and "L" into the circuit in accordance with the wiring diagram () using connectors and housing provided.
6	Using a multimeter (1), check for continuity between the ground connections regulator A (2) and the ground connections regulator B (3). Continuity must NOT be present.

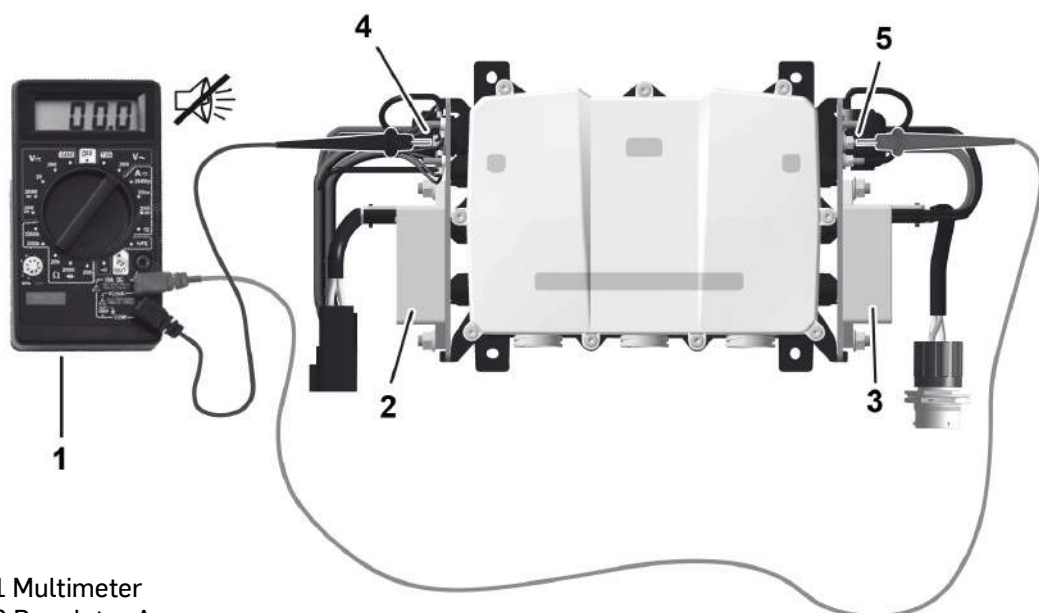

- 1 Multimeter
- 2 Regulator A
- 3 Regulator B
- 4 Ground connections regulator A
- 5 Ground connections regulator B

AE 6iS_0555

Fig. 21

SERVICE INSTRUCTION - PAC

Dynamic propeller balance

Dynamic propeller balancing is required after external alternator set installation. Max tolerated imbalance is 0.5 gram (0.0011 lb) or industry standard of max. 0.05 IPS.

NOTICE

Engine vibrations can be caused by an improperly balanced propeller. Operation without dynamic propeller balancing may cause engine damage.

- Restore aircraft to original operating configuration.
- Connect negative terminal of aircraft battery.

3.7) Test run

Conduct test run.

In case of uninstalled engines test run is accomplished with the mandatory test run after installation into aircraft.



See current Maintenance Manual Line for the respective engine type, Chapter 12-20-00.

Perform a leakage check of the whole system, see current Maintenance Manual Line (MML) for the respective engine type.

3.8) Summary

The execution of the Service Instruction - PAC must be confirmed in the logbook.

| A revision bar outside of the page margin indicates a change to text or graphic.

Translation into other languages might be performed in the course of language localization but does not lie within ROTAX® scope of responsibility.

In any case the original text in English language and the metric units are authoritative.

3.9) Inquiries

Inquiries regarding this Service Instruction - PAC should be sent to the ROTAX® Authorized Distributor of your area.

A list of all ROTAX® Authorized Distributors or their independent Service Centers is provided on <https://dealerlocator.flyrotax.com/>.

SERVICE INSTRUCTION - PAC

4) Appendix

The following drawing should convey additional information:

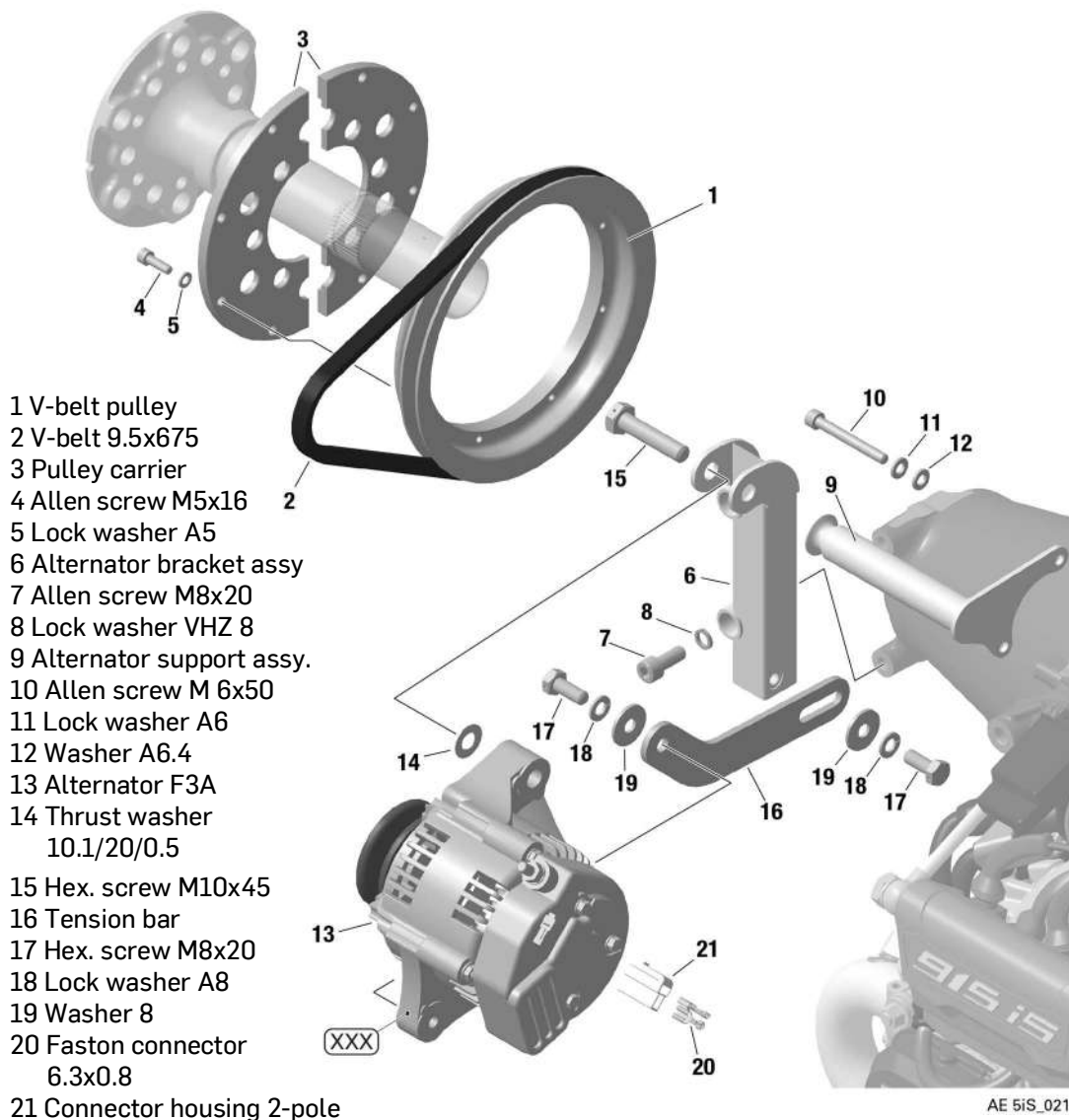

Fig. 22
Alternator set

NOTE: The illustrations in this document show the typical construction. They may not represent full detail or the exact shape of the parts which have the same or similar function.

Exploded views are not technical drawings and are for reference only. For specific detail, refer to the current documents of the respective engine type.