



ROTAX

OPERATORS MANUAL

FOR ROTAX ENGINE TYPE 912 SERIES

REF NO.: OM-912 | PART NO.: 899700



 **WARNING**

Before starting the engine, read the Operators Manual, as it contains important safety relevant information. Failure to do so may result in personal injuries including death. Consult the original equipment manufacturers handbook for additional instructions!

These technical data and the information embodied therein are the property of BRP-Rotax GmbH & CO KG, Austria, acc, BGBl 1984 no. 448, and shall not, without prior written permission of BRP-Rotax GmbH & Co KG, be disclosed in whole or in part to third parties. This legend shall be included on any reproduction of these data, in whole or in part. The Manual must remain with the engine/aircraft in case of sale.

ROTAX[®] is a trade mark of BRP-Rotax GmbH & Co KG. In the following document the short form of BRP-Rotax GmbH & Co KG = BRP-Rotax is used. Other product names in this documentation are used purely for ease of identification and may be trademarks of the respective company or owner.

Copyright 2023 © - all rights reserved.

Translation into other languages might be performed in the course of language localization but does not lie within ROTAX[®] scope of responsibility. In any case the original text in English language and the metric units are authoritative.

Table of Content

Chapter	INTRO – Introduction
Chapter	LEP – LIST OF EFFECTIVE PAGES
Chapter	TOA – Table of amendments
Chapter	1 – General note
Chapter	2 – Operating instructions
Chapter	3 – Abnormal operation
Chapter	4 – Standard operation
Chapter	5 – Performance and Fuel consumption
Chapter	7 – System Description
Chapter	8 – Preservation and storage
Chapter	9 – Supplement

**INTENTIONALLY LEFT
BLANK**

INTRO) Introduction

Topics in this chapter

Foreword

BRP-Rotax GmbH & Co KG (hereinafter “BRP-Rotax”) provides “Instructions for Continued Airworthiness”, which are based on the design, tests and certification of the engine and its components. These instructions apply only to engines and components supplied by BRP-Rotax.

Before operating the engine, read this Operators Manual (OM) carefully. If any passages of the Manual are not clearly understood or in case of any questions, please contact our ROTAX® Authorized Distributors or their independent Service Centers.

This Operators Manual (OM) contains important information about safe operation of the engine together with descriptions of the systems, technical data, operating media and the operational limits of the engine.

The specified information and procedures apply only to the engine and not to specific applications in particular aircraft. The aircraft manufacturers Operators Manual is therefore definitive in terms of the operation of the engine, as it contains all of the aircraft-specific instructions

BRP-Rotax wishes you much pleasure and satisfaction flying your aircraft powered by this ROTAX® aircraft engine.

Document structure

The structure of the Manual follows whenever it is possible the structure of the “GAMA Specification #1 for Pilot’s Operating Handbook”.

**INTENTIONALLY LEFT
BLANK**

LEP) LIST OF EFFECTIVE PAGES

Each new revision to the Operators Manual will have a new List of Effective Pages.

Chapter	Page	Date	Chapter	Page	Date
	cover page			4	January 01 2023
INTRO	1	January 01 2023	3	5	January 01 2023
	2	January 01 2023		6	January 01 2023
LEP	1	January 01 2023		7	January 01 2023
	2	January 01 2023		8	January 01 2023
TOA	1	January 01 2023		9	January 01 2023
	2	January 01 2023		10	January 01 2023
1	1	January 01 2023		11	January 01 2023
	2	January 01 2023		12	January 01 2023
	3	January 01 2023		1	January 01 2023
	4	January 01 2023		2	January 01 2023
	5	January 01 2023		3	January 01 2023
	6	January 01 2023	4	January 01 2023	
	7	January 01 2023	5	January 01 2023	
	8	January 01 2023	6	January 01 2023	
	9	January 01 2023	7	January 01 2023	
	10	January 01 2023	8	January 01 2023	
	11	January 01 2023	1	January 01 2023	
	12	January 01 2023	2	January 01 2023	
	13	January 01 2023	3	January 01 2023	
	14	January 01 2023	4	January 01 2023	
	15	January 01 2023	5	January 01 2023	
	16	January 01 2023	6	January 01 2023	
2	1	January 01 2023	7	January 01 2023	
	2	January 01 2023	8	January 01 2023	
	3	January 01 2023	9	January 01 2023	
			4		

Chapter	Page	Date	Chapter	Page	Date	
5	10	January 01 2023		4	January 01 2023	
	11	January 01 2023		5	January 01 2023	
	12	January 01 2023		6	January 01 2023	
	1	January 01 2023		7	January 01 2023	
	2	January 01 2023		8	January 01 2023	
	3	January 01 2023		9	January 01 2023	
	4	January 01 2023		10	January 01 2023	
	5	January 01 2023		8	1	January 01 2023
	6	January 01 2023			2	January 01 2023
	7	January 01 2023			3	January 01 2023
7	8	January 01 2023		4	January 01 2023	
	1	January 01 2023	9	1	January 01 2023	
	2	January 01 2023		2	January 01 2023	
	3	January 01 2023		rear page		

Summary of amendments

Summary of the relevant amendments in this context, but without any claim to completeness.

current no.	chapter	page	date of change	comments
0	1 up to 9	all	Nov. 01 2016	New layout and change of company name
1	1 up to 9	all	Jan. 01 2023	New text– Intentionally Left Blank
1	1	1-2	Jan. 01 2023	New text
1	1	1–14, 1–17	Jan. 01 2023	from Chapter 1 to Chapter 7
1	3, 4	all	Jan. 01 2023	Chapter changed
1	6	all	Jan. 01 2023	Deleted (part of IM)
1	8	8-2	Jan. 01 2023	New text: Corrosion
1	9	9-2	Jan. 01 2023	New form

1) General note

Topics in this chapter

1.1 General	2
1.2 Abbreviations and terms (depending on respective engine type)	3
1.3 Safety	8
1.4 Safety information	10
1.5 Technical documentation.....	13
1.6 Type description (912 Series)	15

1.1) General

Purpose

The purpose of this Operators Manual (OM) is to familiarize the aircraft manufacturers installing this aircraft engine with operating instructions and safety information.

This document is not intended for use by end customers (private aircraft owners, flight schools...) for operating the engine. Due to various executions of engine installations, only the aircraft manufacturer is able to provide end customers with operation and safety information tailored for a specific aircraft.

Nevertheless, all provided information in this Operators Manual (OM) (such as operating limits, safety information, operation instructions...) must be adhered to. The aircraft manufacturer is obliged to forward this information to the end customer in an appropriate way (e.g. within the aircraft specific Operators Manual (OM)).

For detailed information related to aircraft and aircraft/engine installation, maintenance, safety or flight operation, consult the documentation provided by the aircraft manufacturer and/or its dealer. For additional information on engines, their maintenance or parts, you can also contact your nearest ROTAX® authorized aircraft engines distributor or their independent Service Center.

Engine serial number

When making inquiries or ordering parts, always indicate the engine serial number. Due to continuous product improvement, engines of the same engine type might require different support and spare parts. The engine serial number is located on the top of the crankcase, magneto side.

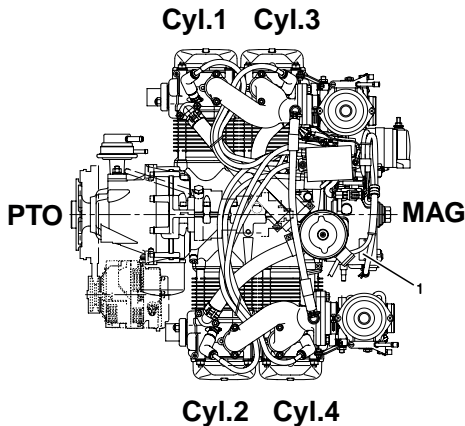



Figure 1: Pos. 1: Engine serial number

1.2) Abbreviations and terms (depending on respective engine type)

Abbreviations	Description
*	Reference to another section
	center of gravity
	The drop symbol indicates use of sealing agents, adhesives or lubricants (only in the Maintenance Manual Heavy)
°C	Degrees Celsius (Centigrade)
°F	Degrees Fahrenheit
rpm	Revolutions per minute
A	Ampere
AAPTS	Ambient Air Pressure Temperature Sensor
AC	alternating current
AD	Airworthiness Directives
Ah	Ampere hour
A/C	Aircraft
AC-DC	EMS Modul voltage converter
AR	as required
assy.	assembly
ASB	Alert Service Bulletin
ACG	Austro Control GmbH
ACL	Anti Collision Light
API	American Petrol Institute
ASTM	American Society for Testing and Materials
ATA	Air Transport Association
AWG	American Wire Gauge
CAN	Controller Area Network
CCS	Camshaft position sensor
Coil 1–4	Ignition coils 1–4
CPS 1+2	Crankshaft Position Sensor 1+2

Abbreviations	Description
CSA	Constant Speed Actuator
CTS	Cooling Temperature Sensor
CW	clockwise
CCW	counter-clockwise
CGSB	Canadian General Standards Board
DCDI	Dual Capacitor Discharge Ignition
DC	direct current
DOA	Design Organisation Approval
DOT	Department of Transport
EASA	European Aviation Safety Agency
IM	Installation Manual
ECU	Engine Control Unit
EGT	Exhaust Gas Temperature
INTRO	Introduction
EMS	Engine Management System
EMS GND	Engine system internal ground reference which is intended to be disconnected from aircraft common ground during flight
EMC	Electromagnetic compatibility
EN	European Standard
ETFE	Ethylene Tetrafluoroethylene
FAA	Federal Aviation Administration
FAR	Federal Aviation Regulations
FOD	Foreign object damage
FL	Flight Level
Fuse box	Power conditioning and distribution for the Engine Management System
hr.	hours
HIC A	Harness Interface Connector A
HIC B	Harness Interface Connector B
IAT	Indicated Air Temperature

Abbreviations	Description
ICA	Instructions for Continued Airworthiness
IFR	Instrument Flight Rules
IFSD	In-flight-shutdown
INJ 1–8	Injector 1–8
IPC	Illustrated Parts Catalog
ips	inch per second
iRMT	independent ROTAX Maintenance Technician
ISA	International Standard Atmosphere
kg	Kilograms
KNOCK	Knock sensor
Lane A	System A of Engine Management System
Lane B	System B of Engine Management System
LOPC	Loss of power control
MAPS 1 & 2	Manifold Air Pressure Sensor 1 & 2
MATS 1 & 2	Manifold Air Temperature Sensor 1 & 2
MON	Motor Octane Number
MAG	Magneto Side
N	Newton
n.a.	not available
NDT	Non Destructive Testing
NEW	Part must be replaced against NEW (mentioned in figures)
Nm	Newtonmeter
NVFR	Night Visual Flight Rules
OAT	Outside Air Temperature
OHM	Overhaul Manual
OHV	Over Head Valve
OM	Operators Manual
OPS	Oil Pressure Sensor

Abbreviations	Description
OTS	Oil Temperature Sensor
PCD	Pitch Circle Diameters
PCV	Pressure Control Valve
PMA	Permanent magnet alternator
POA	Production Organization Approval
PS	Power supply
PTFE	Polytetrafluoroethylene (Teflon)
PTO	Power Take Off
Rev.	Revision
ROTAX®	is a trademark of BRP-Rotax GmbH & Co KG
RON	Research Octane Number
RON 424	ROTAX® Standard 424
s.v.	still valid (only Illustrated Parts Catalog)
S/N	Serial Number
SAE	Society of Automotive Engineers
SEP	Single Engine Piston
SB	Service Bulletin
SI	Service Instruction
SI-PAC	Service Instruction Parts and Accessories
SPST	Single pole single throw
STP	Shielded twisted pair wire
SL	Service Letter
SMD	Surface Mounted Devices
TBO	Time Between Overhaul
TC	Type certificate
part no.	part number
TOA	Table Of Amendments
TOC	Table Of Contents
TPS	Throttle Position Sensor
TSN	Time Since New

Abbreviations	Description
TSNP	Time Since New Part
TSO	Time Since Overhaul
V	Volt
VFR	Visual Flight Rules
LEP	List of Effective Pages
MM	Maintenance Manual
MEP	Multi Engine Piston
X3	Connector on Engine Management System wiring harness which serves as an interface for power supply
XXXX	shows the component serial number

1.3) Safety

Although reading such information does not eliminate any hazards, it promotes understanding, and applying the information will promote correct use of the engine. Always apply common workshop safety rules.

The information and descriptions of components and systems contained in this Manual are correct at the time of publication. BRP-Rotax maintains a policy of continuous improvement of its products without imposing upon itself any obligation to retrofit products previously manufactured.

Revisions

BRP-Rotax reserves the right to remove, replace or discontinue any design, specification, feature or other at any time, and without incurring obligation.

Measurement

Specifications are given in the SI metric system with the imperial and US customary measurement system equivalents in parenthesis.

Symbols used

This Manual uses the following symbols to emphasize particular information. This information is important and must be observed.

⚠ WARNING

Identifies an instruction which, if not followed, may cause serious injury or even fatal injury.

⚠ CAUTION

Identifies an instruction which, if not followed, may cause minor or moderate injury.

NOTICE

Identifies an instruction which, if not followed, may severely damage the engine or could void any warranty.

NOTE

Indicates supplementary information which may be needed to fully complete or understand an instruction.

ENVIRONMENTAL NOTE

Environmental notes give you tips on environmental protection.

A revision bar outside the page margin indicates a change to text or graphic.

1.4) Safety information

Use for intended purpose

⚠ WARNING

Non-compliance can result in serious injuries or death!

Never fly the aircraft equipped with this engine at locations, air speeds, altitudes or in other situations which do not allow a successful no-power landing after sudden engine stoppage.

- This engine is not suitable for acrobatics (inverted flight, etc.). Flight attitudes outside the permissible limits are not allowed.
- This engine has exclusively been developed and tested for gyrocopter, pusher and tractor applications. In case of any other usage, the OEM is responsible for testing and the correct function of the engine.
- It should be clearly understood that the choice, selection and use of this particular engine on any aircraft is at the sole discretion and responsibility of the aircraft manufacturer, assembler and owner/user.
- Due to the varying designs, equipment and types of aircraft, BRP-Rotax grants no warranty on the suitability of its engine's use on any particular aircraft. Further, BRP-Rotax grants no warranty on this engine's suitability with any other part, components or system which may be selected by the aircraft manufacturer, assembler or user for aircraft application.

⚠ WARNING

Non-compliance can result in serious injuries or death!

For each use of DAY VFR, NIGHT VFR or IFR in an aircraft the applicable legal requirements and other existing regulations must be adhered to.

- Certain areas, altitudes and conditions present greater risk than others. The engine may require humidity or dust/sand preventative equipment, or additional maintenance may be required.
- You should be aware that any engine may seize or stall at any time. This could lead to a crash landing and possible severe injury or death. For this reason, we recommend strict compliance with the maintenance and operation and any additional information which may be given to you by your dealer.

- Training**
- Whether you are a qualified pilot or a novice, complete knowledge of the aircraft, its controls and operation is mandatory before a solo flight. Flying any type of aircraft involves a certain amount of risk. Be informed and prepared for any situation or hazard associated with flying.
 - A recognized training program and continued education for piloting an aircraft is absolutely necessary for all aircraft pilots. Make sure you also obtain as much information as possible about your aircraft, its maintenance and operation from your dealer.
 - Engine-specific training courses are provided by the authorized distributors according to manufacturer specifications (iRMT).
- Regulations**
- Respect all legal requirements or local rules pertaining to flight operation in your flying area. Only fly when and where conditions, topography, and airspeeds are safest.
 - Consult your aircraft dealer or manufacturer and obtain the necessary information, especially before flying in new areas.
- Instrumentation**
- Select and use proper aircraft instrumentation. This instrumentation is not included in the ROTAX® engine package. Verification to the latest regulations such as FAR or EASA has to be conducted by the aircraft manufacturer.
- Engine log book**
- Keep an engine log book and respect engine and aircraft maintenance schedules. Keep the engine in top operating condition at all times. Do not operate any aircraft which is not properly maintained or has engine operating irregularities which have not been corrected.
- Maintenance (iRMT)**
- Since special training, tools and equipment are required, engine servicing shall only be performed by an authorized ROTAX® aircraft engine distributor or their independent service center. BRP-Rotax requires that any service or maintenance work be carried out and verified by a technician that has a current iRMT rating.
 - When the engine will not be operated for a longer period protect the engine and fuel system from contamination and environmental exposure.
- Engine operation**
- Never operate the engine without sufficient quantities of operating fluids (oil, coolant, fuel).
 - Never exceed the maximum permitted operational limits.
 - In the interest of safety, the aircraft must not be left unattended while the engine is running.

- To eliminate the risk of injury or damage, ensure any loose equipment or tools are properly secured before starting the engine.
- Allow the engine to cool at idle for several minutes before turning off the engine.

Vacuum pump

- This engine may be equipped with a vacuum pump. The safety warning accompanying the vacuum pump must be given to the owner/operator of the aircraft into which the vacuum pump is installed.

1.5) Technical documentation

These documents form the instructions ensuring continued airworthiness of ROTAX® aircraft engines.

The information contained herein is based on data and experience that are considered applicable for authorized mechanics (iRMT, see Maintenance Manual Line (MML)) under normal conditions.

Due to the fast technical progress and fulfillment of particular specifications of the customers it may occur that existing laws, safety prescriptions, constructional and operational regulations may not be sufficient or cannot be transferred completely to the object bought, in particular for special constructions.

Documentation

- Installation Manual
- Operators Manual
- Maintenance Manual (Line and Heavy Maintenance)
- Overhaul Manual
- Illustrated Parts Catalog
- Alert Service Bulletins
- Service Bulletins
- Service Instructions
- Service Instruction–Parts and Accessories
- Service Letters



Status

The status of Manuals can be determined by checking the table of amendments. The first column of this table indicates the revision status which should be compared with the revision provided on the ROTAX®-Website: www.FLYROTAX.com Amendments and current versions can be downloaded free of charge.

Replacement pages

Furthermore the Manual is constructed in such a way that single pages can be replaced instead of the complete document. The list of effective pages is given in the chapter LEP. The particular edition and revision number is given on the footer of each page.

Reference

Any reference to a document refers to the latest edition issued by BRP-Rotax if not stated otherwise.



This symbol informs you of additional references (data sheets, Manuals, etc.) associated with the given subject.

Illustrations

The illustrations in this Manual are merely sketches and show typical arrangements. They may not represent full detail or the exact shape of the parts but should outline the same or similar function. Therefore deriving dimensions or other details from illustrations is not permitted.

TYPICAL indicates a general view which may not represent exact details..

NOTE

The Illustrations in this Manual are stored in a graphic data base system and are provided with a consecutive irrelevant number.

This number (e.g. AE 5iS001) is of no significance for the content.

1.6 Type description (912 Series)

The type description consists of the following:

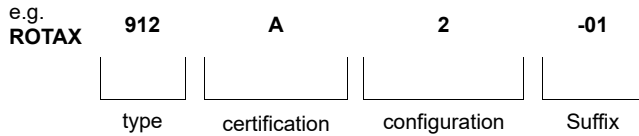

Designation

Designation		Description
Type	912	4 –cyl. horizontally opposed, normal aspirated engine
Certification	A	Certified to JAR 22 (TC No. EASA.E.121)
	F, S	Certified to FAR 33 (TC No. E00051 EN) JAR-E (TC No. EASA.E.121)
	UL, ULS	Non-certified aircraft engines
Configuration	2	Prop shaft with flange for fixed pitch propeller.
	3	Prop shaft with flange for constant speed propeller and drive for hydraulic governor for constant speed propeller.
Suffix	-XX	Explanation of the type designation suffix, see SB-912-068

Options

Available options (optional equipment) for the engine type mentioned above:

	external alternator	vacuum pump	drive for rev counter/ hour meter	governor
for configuration 2	yes	yes	yes	no
for configuration 3	yes	no	yes	yes

NOTE

Conversion of the configuration 2 to configuration 3 may be accomplished by ROTAX® authorized aircraft engines distributors or their Independent service centers.

**INTENTIONALLY LEFT
BLANK**

2) Operating instructions

Topics in this chapter

2.1 Operating limits (912 A/F/UL).....	2
2.2 Operating limits (912 S/U/LS)	5
2.3 Operating media-Coolant.....	9
2.4 Operating media – Fuel.....	10
2.5 Operating media-Lubricants.....	11

The data of the certified engine are based on the type certificate of type 912 A JAR 22 (TC No. EASA.E.121), 912 F/S FAR 33 (TC No. E00051 EN), JAR-E (TC No. EASA.E. 121).

Introduction

The operating limits for certified engines are also given in the type certificate for the relevant engine type.

This chapter of the Operators Manual (OM) contains the operating limits that must be observed and adhered to while operating this type of engine.

2.1) Operating limits (912 A/F/UL)

Performance

Performance data relate to ISA (International Standard Atmosphere) conditions without Governor, external alternator etc.

Take-off performance	59.6 kW at 5800 rpm
Max. continuous performance	58 kW at 5500 rpm

Speed

Speed	
Take-off speed	5800 rpm (max. 5 min.)
Max. continuous speed	5500 rpm
Idle speed	min. 1400 rpm

Acceleration

Limit of engine operation at zero gravity and in **negative “g”** condition.

Max: 5 seconds at max. -0.5g.

Oil pressure

Oil pressure	
Max.	7 bar (102 psi)
Min.	0.8 bar (11.6 psi) (below 3500 rpm) 1.5 bar (22 psi) ¹
Normal	2.0 to 5.0 bar (29–72.5 psi) (above 3500 rpm) 1.5 to 5.0 bar (22 psi-72.5 psi) ¹

NOTICE

Oil pressure max. for a short period admissible at cold start.

Oil temperature

Oil temperature	
Max.	140 °C (285 °F)
Min.	50 °C (122 °F)
normal operating temperature approx. 90 to 110 °C (190-230 °F)	

1. 912 UL to S/N 4 402 387/912 A to S/N 4 410 266 /912 F to S/N 4 412 764

EGT

Exhaust gas temperature	
Max.	880 °C (1616 °F)

Conventional coolant

Applicable for engine S/N without Suffix -01. [See also Chapter 2.3.](#)

Coolant temperature: (coolant exit temperature)	
Max.	120 °C (248 °F)

Cylinder head temperature:	
Max.	150 °C (302 °F)
Permanent monitoring of coolant temperature and cylinder head temperature is necessary.	

Waterless coolant

[See also Chapter 2.3](#)

Cylinder head temperature:	
Max.	150 °C (302 °F)
Permanent monitoring of cylinder head temperature is necessary.	

Conventional coolant

[See also Chapter 2.3](#)

Applicable for engine S/N with Suffix -01.

Coolant temperature limit measured in the cylinder head	Engine type
Max. 120 °C (248 °F)	912 A/F/UL
Permanent monitoring of coolant temperature is necessary.	

Engine start, operating temperature

Max.	50 °C (122 °F) (ambient temperature)
Min.	-25 °C (-13 °F) (oil temperature)

Fuel pressure

⚠ WARNING

Non-compliance can result in serious injuries or death!
Fuel pressure in excess of stated limit can lead to an override of the float valve with subsequent engine stop.

The aircraft engine manufacturer strongly recommends the installation of an additional pump, unless this has not been covered by legal obligations so far.

Fuel pressure	
Max.	0.4 bar (5.8 psi) (0.5 bar (7.26 psi)) ²
Min.	0.15 bar (2.2 psi)

NOTE

Low fuel pressure indications are possible and allowed. But the pressure must stabilize to the operating limit within 10 seconds. If not, the cause should be determined and rectified. Due to the technical design and installation conditions (construction of the return line, etc.) pressure fluctuations, at the fuel pump are possible. These pressure fluctuations within the specified operating limits are not considered a problem.

Propeller governor

Power consumption of the hydraulic propeller governor:	
Max.	600 W

Vacuum pump

Power consumption of the vacuum pump:	
Max.	300 W

External alternator

Power consumption of the external alternator:	
Max.	1200 W

2. applicable only for fuel pump from S/N 11.0036

Bank angle

Deviation from bank angle:	
Max.	40°

NOTE

Up to this value the dry sump lubrication system warrants lubrication in every flight situation.

2.2) Operating limits (912 S/ULS)

Performance

Performance data relate to ISA (International Standard Atmosphere) conditions without Governor, external alternator etc.

Take-off performance	73.5 kW at 5800 rpm
Max. continuous performance	69 kW at 5500 rpm

Speed

Speed	
Take-off speed	5800 rpm (max. 5 min.)
Max. continuous speed	5500 rpm
Idle speed	min. 1400 rpm

Acceleration

Limit of engine operation at zero gravity and in **negative „g“** condition.
Max. 5 seconds at max. -0.5 g

Oil pressure

Oil pressure	
Max.	7 bar (101.5 psi)
Min.	0.8 bar (11.6 psi) (below 3500 rpm)
Normal	2.0 to 5.0 bar (29-72.5 psi) (above 3500 rpm)

NOTICE

Oil pressure max. for a short period admissible at cold start.

Oil temperature

Oil temperature	
Max.	130 °C (266 °F)
Min.	50 °C (122 °F)
normal operating temperature: approx. 90 to 110 °C (190-230 °F)	

EGT

Exhaust gas temperature	
Max.	880 °C (1616 °F)

Conventional coolant

See also [Chapter 2.3](#).

Applicable for engine S/N without Suffix -01.

Coolant temperature: (coolant exit temperature)	
Max.	120 °C (248 °F)

Cylinder head temperature	
Max.	135 °C (275 °F)
Permanent monitoring of coolant temperature and cylinder head temperature is necessary.	

Waterless coolant

Cylinder head temperature	
Max.	135 °C (275 °F)
Permanent monitoring of cylinder head temperature is necessary.	

Conventional coolant

Applicable for engine S/N with Suffix -01.

Coolant temperature limit measured in cylinder head	Engine type
Max. 120 °C (248 °F)	912 S/ULS
Permanent monitoring of coolant temperature is necessary.	

Engine start, operating temperature

Max.	50 °C (122 °F) (ambient temperature)
Min.	-25 °C (-13 °F) (Oil temperature)

Fuel pressure

⚠ WARNING

Non-compliance can result in serious injuries or death!
Exceeding the max admissible fuel pressure will override the float valve of the carburetor and lead to engine stoppage.

The aircraft engine manufacturer strongly recommends the installation of an additional pump, unless this has not been covered by legal obligations so far.

Fuel pressure

Max.	0.4 bar (5.8 psi) (0.5 bar (7.26 psi)) ³
Min.	0.15 bar (2.2 psi)

NOTE

Low fuel pressure indications are possible and allowed. But the pressure must stabilize to the operating limit within 10 seconds. If not, the cause should be determined and rectified. Due to the technical design and installation conditions (construction of the return line, etc.) pressure fluctuations, at the fuel pump are possible. These pressure fluctuations within the specified operating limits are not considered a problem.

Propeller governor

Power consumption of the hydraulic propeller governor:

Max.	600 W
------	-------

Vacuum pump

Power consumption of the vacuum pump:

Max.	300 W
------	-------

3. applicable only for fuel pump from S/N 11.0036

External alternator

Power consumption of the external alternator:	
Max.	1200 W

Bank angle

Deviation from bank angle:	
Max.	40°

NOTE

Up to this value the dry sump lubrication system warrants lubrication in every flight situation.

2.3) Operating media-Coolant

NOTICE

Obey the latest edition of Service Instruction SI-912-016, for the selection of the correct operating media.

Conventional coolant

Conventional coolant mixed with water has the advantage of a higher specific thermal capacity than water-less coolant.

Application

When correctly applied, there is sufficient protection against vapor bubble formation, freezing or thickening of the coolant within the operating limits.

Use the coolant specified in the manufacturer's documentation.

Mixture

NOTICE

Obey the operating media manufacturer's instructions!

Applicable for engine S/N without Suffix -01.

Designation	Mixture ratio %	
	Concentrate	Water
conventional e.g. BASF Glysantine anticorrosion	50*	50
waterless e.g. Aero Cool 180°	100	0

* coolant component can be increased up to max. 65 %.

Applicable for engine S/N with Suffix -01.

Designation	Mixture ratio %	
	Concentrate	Water
conventional e.g. BASF Glysantine anticorrosion	50*	50

* coolant component can be increased up to max. 65 %.

2.4) Operating media – Fuel

NOTICE
Obey the latest edition of Service Instruction SI-912-016, for the selection of the correct operating media.

NOTICE
Use only fuel suitable for the respective climatic zone.

NOTE

Risk of vapour formation if using winter fuel for summer operation.

The fuels with following specifications can be used.

Antiknock properties

	Usage/Description	
	912 A/F/UL	912 S/ULS
Anti knock properties	Min. RON 90 (min. AKI ⁴ 87)	Min. RON 95 (min. AKI ⁴ 91)

NOTE

For fuels according to ASTM D4814 specifications following AKI (Anti Knock Index) value has to be observed: e.g. min. AKI 91.

MOGAS

	Usage/Description	
	MOGAS	912 S/ULS
European standard	EN 228 normal EN 228 super EN 228 super plus	EN 228 super EN 228 super plus

AVGAS

AVGAS 100LL places greater stress on the valve seats due to its high lead content and forms increased deposits in the combustion chamber and lead sediments in the oil system.

4. Anti Knock Index (RON+MON)/2

	Usage/Description	
AVGAS	912 A/F/UL	912 S/ULS
Aviation Standard	AVGAS 100 LL (ASTM D910)	AVGAS 100 LL (ASTM D910)

2.5) Operating media-Lubricants

NOTICE
<p>Obey the manufacturer's instructions about the lubricants. If the engine is mainly run on AVGAS more frequent oil changes will be required. See Service Information SI-912-016, latest edition.</p>

Oil type



At the selection of suitable lubricants refer to the additional information in the Service Information SI-912-016, latest edition.

Oil consumption

Max. 0.06 l/h (0.13 liq pt/h)

Oil specification

- Use only oil with RON 424 classification

NOTE

The ROTAX® Norm 424 (RON 424) is a BRP-Rotax internal standard, which is only available on special request via the ROTAX® authorized distributor and will not be disclosed to third parties without prior consent.

- Due to the high stresses in the reduction gears, oils with gear additives such as high performance motor cycle oils are required.
- Because of the incorporated overload clutch, oils with friction modifier additives are unsuitable as this could result in clutch slippage during normal operation.
- Heavy duty 4-stroke motor cycle oils meet most of the requirements. These oils are normally not mineral oils but semi- or full synthetic oils.
- Oils primarily for Diesel engines have **insufficient high temperature properties and additives which favour clutch slipping, and are generally unsuitable.**

Oil viscosity

Use of multi-grade oils is recommended.

NOTE

Multi-viscosity grade oils are less sensitive to temperature variations than single grade oils. They are suitable for use throughout the seasons, ensure rapid lubrication of all engine components at cold start and get less fluid at higher temperatures.

Table of lubrication

Since the temperature range of neighboring SAE grades overlap, there is no need for change of oil viscosity at short duration of ambient temperature fluctuations.

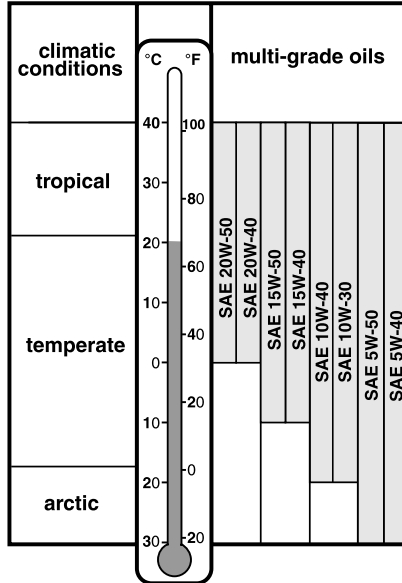

AE 2_0064

Figure 1: Temperature range

3) Abnormal operation

Topics in this chapter

3.1 Re-Start during flight	3
3.2 Exceeding max. admissible engine speed	3
3.3 Temperature	3
3.3.1 Exceeding of max. admissible cooling system temperature	3
3.3.2 Exceeding of max. admissible cyl. head temperature	3
3.3.3 Exceeding of max. admissible coolant temperature	4
3.3.4 Exceeding of max. admissible oil temperature	4
3.4 Oil pressure	4
3.4.1 Oil pressure below minimum - on ground	5
3.4.2 Oil pressure above permitted range at low ambient temperatures.....	5
3.5 Engine on fire or fire in the engine compartment	5
3.6 Troubleshooting	6

⚠ WARNING

Non-compliance can result in serious injuries or death!

Unless stated otherwise in this chapter, operating an engine with limited airworthiness is not permitted. At unusual engine behavior conduct checks as per Maintenance Manual Line (MML) Chapter 05-50-00 before the next flight. Only qualified staff (authorized by the Aviation Authorities) trained on this particular engine, is allowed to carry out maintenance and repair work.

The following description of procedures depends on the respective type of installation in the aircraft and shall therefore only be seen functionally.

3.1) Re-Start during flight

If the propeller continues to rotate during flight by windmilling, but the speed is not sufficient to start the engine, the electric starter can be used. It is not required to wait until the propeller stops rotating.

3.2) Exceeding max. admissible engine speed

Exceeding engine speed

Reduce the engine speed. Any exceeding of the max. admissible engine speed must be entered by the pilot into logbook, stating the exact time and duration of engine over speed.

- A maintenance inspection should be carried out

3.3) Temperature

NOTICE

Reduce engine power setting to the minimum necessary and carry out precautionary landing.

3.3.1) Exceeding of max. admissible cooling system temperature

NOTICE

Reduce engine power setting to the minimum necessary and carry out precautionary landing.

3.3.2) Exceeding of max. admissible cyl. head temperature

NOTICE

Reduce engine power setting to the minimum necessary and carry out precautionary landing.

Cylinder head temperature max.

Applicable for engine S/N without Suffix -01.

- Any exceeding of the max. admissible cylinder head temperature must be entered by the pilot into the logbook, stating duration and extent of over-temperature condition.
- Carry out an unscheduled maintenance check according to Maintenance Manual Line (MML) chapter 05-50-00.

3.3.3) Exceeding of max. admissible coolant temperature

NOTICE

Reduce engine power setting to the minimum necessary and carry out precautionary landing.

Coolant temperature max.

Applicable for engine S/N with Suffix -01.

- Any exceeding of the max. admissible coolant temperature must be entered by the pilot into the logbook, stating duration and extent of over-temperature condition.
- Carry out an unscheduled maintenance check according to Maintenance Manual Line (MML) chapter 05-50-00.

3.3.4) Exceeding of max. admissible oil temperature

NOTICE

Reduce engine power setting to the minimum necessary and carry out precautionary landing.

Exceeding oil temperature

- Any exceeding of the max. oil temperature must be entered by the pilot in the logbook, stating duration and extent of over-temperature condition.
- A maintenance inspection should be carried out.

3.4) Oil pressure

NOTICE

Reduce engine power setting to the minimum necessary and carry out precautionary landing.

Oil pressure

Oil pressure below minimum - during flight

- Check oil system.
- A maintenance inspection should be carried out.

3.4.1) Oil pressure below minimum - on ground

Oil pressure too low

Immediately stop the engine and check for reason. Check oil system.

- Check oil quantity in oil tank.
- Check oil quality. See Chapter: Operating media-Lubricants.
- A maintenance inspection should be carried out.

3.4.2) Oil pressure above permitted range at low ambient temperatures

NOTICE

Reduce engine power setting to the minimum necessary and carry out precautionary landing.

Oil pressure too high

- Reduce engine speed and check the oil pressure again once it has reached a higher oil temperature
- A maintenance inspection should be carried out

3.5) Engine on fire or fire in the engine compartment

NOTICE

Carry out emergency procedures as prescribed in the flight manual of the aircraft manufacturer.

- After landing locate the cause of fire and resolve the error before next flight by qualified staff (authorized by the Aviation Authorities)
- An entry in the logbook must be made
- A maintenance inspection should be carried out

3.6) Troubleshooting

⚠ WARNING

Non-compliance can result in serious injuries or death!
Only qualified staff (authorized by the Aviation Authorities) trained on this particular engine, is allowed to carry out maintenance and repair work.

NOTICE

If the following hints regarding remedy do not solve the problem, contact an authorized distributor. The engine must not be operated until the problem is rectified.



All checks in accordance with the Maintenance Manual , current issue.

Starting problems

Engine does not start

Possible cause	Remedy
Ignition OFF	Switch ON
Closed fuel valve or clogged filter.	Open valve, clean or renew filter, check fuel system for leaks.
No fuel in tank.	Refuel.
Starting speed too low, faulty or discharged battery.	Fit fully charged battery.
Starting speed too low, start problems on cold engine.	Use top quality, low friction oil; allow for sufficient cooling period to counter for performance drop on hot starter; preheat engine.
Wrong fuel (Jetfuel or Diesel).	Change of fuel.

Engine run

Engine keeps running while ignition switch is turned off

Possible cause	Remedy
Overheating of engine.	Let engine cool down at idling at approx. 2000 rpm.

Knocking under load

Possible cause	Remedy
Octane rating of fuel too low.	Use fuel with higher octane rating.

Engine idles rough after warm-up period, smoky exhaust emission.

Possible cause	Remedy
Starting carb (Choke) activated.	Close starting carb (Choke).

Oil pressure

Low oil pressure

Possible cause	Remedy
Not enough oil in oil tank.	Refill oil.
Oil too hot.	Cool down oil.

High oil pressure

Possible cause	Remedy
Oil too cold.	Cover oil cooler or install thermostat.
Wrong viscosity of oil.	Change oil to lower viscosity.

Oil level

Oil level is increasing

Possible cause	Remedy
Oil too cold during engine operation.	Cover oil cooler surface, maintain the oil temperature prescribed.
Contamination with diesel fuel.	Check fuel for diesel contamination and purge entire fuel system if diesel is found.

Possible cause	Remedy
Starting speed too low.	Preheat engine.
Faulty or discharged battery.	Fit fully charged battery.
High oil pressure.	At cold start an oil pressure reading of up to around 7 bar (101.5 psi) does not indicate a malfunction.
Oil pressure too low after cold start.	Too much resistance in the oil suction system at low temperatures due to cold oil. Stop engine and preheat oil. After a cold start the oil tank must be observed and the oil pressure should be above 1.5 bar (22 psi). Otherwise, the speed must be lowered again, because not enough cold oil can be sucked. If oil pressure is reading lower than 1 bar (15 psi) oils with lower viscosity are to be used. See SI-912-001, current issue.

NOTE

Oil pressure must be measured at idle at an oil temperature of minimum 50 °C (122 °F). Be sure the oil pressure does not go below minimum at idle.

4) Standard operation

Topics in this chapter

4.1 Daily checks	2
4.2 Before engine start	5
4.3 Pre-flight checks	5
4.4 Engine start	6
4.5 After engine start	8
4.6 Take-off	9
4.7 Cruising	9
4.8 Engine shut-off.....	10
4.9 Cold weather operation	10

Introduction

To warrant reliability and efficiency of the engine, meet and carefully observe all the operating and maintenance instructions.

The following description of procedures depends on the respective type of installation in the aircraft and shall therefore only be seen functionally.

NOTE

The control elements mentioned in this chapter are only symbolic and should support the understanding of the procedures. The execution of control elements is in the responsibility of the aircraft manufacturer.

4.1) Daily checks

Safety

To warrant reliability and efficiency of the engine, meet and carefully observe all the operating and maintenance instructions.

⚠ WARNING

Risk of burns and scalds! Hot engine parts!
Conduct checks on cold engine only!

⚠ WARNING

Non-compliance can result in serious injuries or death!
Ignition "OFF" Before moving the propeller switch off both ignition circuit and secure the aircraft. Have the cockpit occupied by a competent person.

NOTICE

If established abnormalities (e.g. excessive resistance of the engine, noise etc.) inspection in accordance with the relevant Maintenance Manual is necessary. Do not release the engine into service before rectification.

Coolant level

NOTICE

Operating media must be observed.
Inappropriate coolant quantity can lead to serious engine damage.

The specifications given in [Chapter 2.3](#) must be adhered to when refilling coolant.

Step	Procedure
1	Verify coolant level in the expansion tank , replenish as required up to top. The max. coolant level must be flush with the bottom of the filler neck.
2	Verify coolant level in the overflow bottle , replenish as required. The coolant level must be between max. and min. mark.

ENVIRONMENTAL NOTE

Protect the environment!
Do not harm the environment by spilling coolant. Dispose coolant in an environmentally friendly manner.

Expansion tank

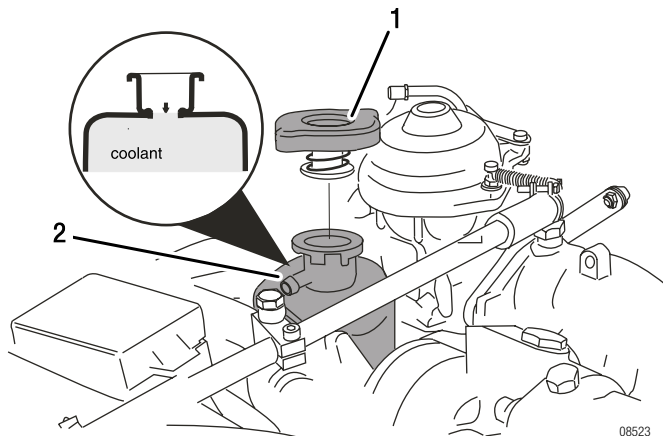

08523

Figure 1: Expansion tank

1 Radiator cap

2 Expansion tank

Overflow bottle

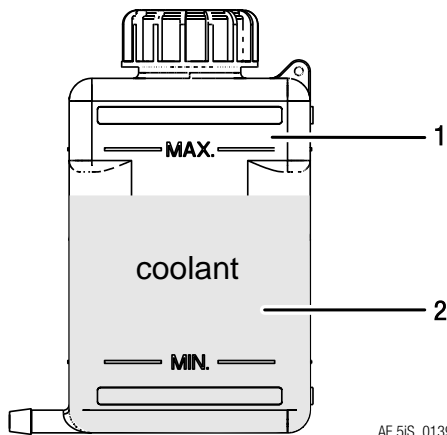

AE 5IS_0139

Figure 2: Overflow bottle

1 Overflow bottle

2 Coolant

Mech./electronic components

Check of mechanical/electronic components.

Step	Procedure
1	Turn propeller slowly by hand in direction of engine rotation several times and observe engine for odd noises or excessive resistance and normal compression.
2	Verify free movement of throttle valve and the complete range.
3	Inspect for damages, leakage and general condition of exhaust system.
4	Visual inspection for mechanical and thermal damages of sensor, actuators and the wiring harness.

Gearbox

Version **without** overload clutch:
No further checks are necessary.

Version **with** overload clutch:

Step	Procedure
1	Turn the propeller by hand back and forth, feeling the free rotation of 30° before the crankshaft starts to rotate. If propeller can be turned between the dogs with little force (lower than 25 Nm (19 ft.lb)), further inspection is required.

Carburetor

Step	Procedure
1	Verify free movement of throttle cable and starting carburetor over the complete range. Check from the cockpit.

Exhaust system

Step	Procedure
1	Inspect for damages, leakage and general condition.

4.2) Before engine start

Carry out pre-flight checks.

4.3) Pre-flight checks

Safety

⚠ WARNING	
Risk of burns and scalds! Hot engine parts! Conduct checks on cold engine only!	

Operating media

Step	Procedure
1	Check for any oil-, coolant- and fuel leaks. If leaks are evident, rectify and repair them before next flight.

Oil level

NOTICE	
Operating media must be observed. Inappropriate oil quantity can lead to serious engine damage.	

The specifications given in [Chapter 2.4](#) must be adhered to when refilling oil.

Step	Procedure
1	NOTE <i>Propeller shouldn't be turned in reverse of the normal direction of engine rotation.</i> Remove bayonet cap from the oil tank, turn the propeller slowly by hand in direction of engine rotation several times to pump residual oil from the engine into the oil tank.
2	It is essential to build up compression in the combustion chamber. Maintain the pressure for a few seconds to let the gas flow via the piston rings into the crankcase. The speed of rotation is not important but rather the continuous pressure and the amount of gas which is transferred into the crankcase.
3	This process is finished when air is returning back to the oil tank and can be noticed by an audible gurgle from the open oil tank.

Step	Procedure
4	<p>Check oil level and add oil if necessary. The oil level should be in the upper half (between the "50%" and the "max" mark) and should never falls below the "min." mark of the oil dipstick. Prior to long flights oil should be added so that the oil level reaches the "max" mark. Avoid oil levels exceeding the "max" mark, since excess oil could be poured out through the venting system. Difference between max.- and min.- mark = 0.45 litre (0.95 liq pt). Oil consumption max 0.06 l/h (0.13 liq pt/h).</p>
5	Re-install bayonet cap.

ENVIRONMENTAL NOTE

Protect the environment.

Do not harm the environment by spilling oil. Dispose of oil in an environmentally friendly manner.

4.4) Engine start

⚠ WARNING

Non-compliance can result in serious injuries or death!

Do not start the engine if any person is near the engine.

Engine start

Step	Designation	Procedure
1	Fuel valve	open
2	Starting carb (choke)	activated
	IF engine in operating temperature	Then start the engine without choke.
3	Throttle lever	set on idle position
4	Master switch	ON
5	Ignition	both circuits switched on

NOTICE

Do not actuate starter button (switch) as long as the engine is running. Wait until complete stop of engine!

Step	Designation	Procedure
6	Starter button	actuate

NOTICE

Activate starter for maximum of 10 consecutive seconds only, followed by a cooling period of 2 minutes.

Step	Designation	Procedure
7	As soon as engine runs	adjust throttle to achieve smooth running at approx. 2500 rpm.
8	Oil pressure	check if oil pressure has risen within 10 seconds and monitor oil pressure. Increase of engine speed is only permitted at steady oil pressure readings above 2 bar (30 psi).

NOTICE

At an engine start with low oil temperature, continue to observe the oil pressure as it could drop again due to the increased flow resistance in the suction line. Engine rpm may only be increased so far as the oil pressure re-mains steady.

Step	Designation	Procedure
9	Starting carb (choke)	de-activate

NOTICE

Since the engine comprises a reduction gear with shock absorber, take special care of the following:

Step	Procedure
1	To prevent impact load, start with throttle lever in idle position or at the most up to 10% open.
2	For the same reason, wait for around 3 sec. after throttling back to partial load to reach constant speed before re-acceleration..
3	For checking the two ignition circuits, only one circuit may be switched off and on at a time.

4.5) After engine start**⚠ WARNING**

Non-compliance can result in serious injuries or death!
Do not start the engine if any person is near the engine.

Warming up period

Step	Procedure
1	Start warming up period at approx. 2000 rpm for approx. 2 minutes.
2	Continue at 2500 rpm, duration depending on ambient temperature, until oil temperature reaches 50 °C (122 ° F).
3	Check temperatures and pressure.

Throttle response**NOTICE**

After a full-load ground test allow a cooling run at idle speed to prevent vapour formation in the cylinder head.

Step	Procedure
1	Full throttle ground test (consult Aircraft Operators Manual (OM) since engine speed depends on the propeller used).

Ignition check

After engine warm – up and prior to take –off, check the two ignition circuits at **4000 rpm** (approx. 1700 rpm propeller).

Step	Procedure
1	Speed (engine rpm) drop with only one ignition circuit must not exceed 500 rpm (approx. 210 rpm propeller).
2	150 rpm (approx. 65 rpm propeller) max. difference of speed (engine rpm) by use of either circuit, A or B.

NOTE

The propeller speed depends on the actual reduction ratio.

Propeller governor

Check of hydraulic propeller governor:

Check control of the hydraulic propeller governor to specifications of the manufacturer.

NOTE

Cycling the propeller governor puts a relatively high load on the engine. Unnecessary cycling or additional checks should be avoided.

4.6) Take-off

⚠ WARNING
Non-compliance can result in serious injuries or death! Monitor Operating limits. Limits must not be exceeded.

Climb

Climbing with engine running at take-off performance is permissible (max. 5 minutes).

See [Chapter 2.1 Operating limits](#)

4.7) Cruising

Performance

Step	Procedure
1	Set performance as per performance specifications Chapter 5 and respect operating limits as per Chapter 2.1 Operating limits .

Oil temperature

Step	Procedure
1	Avoid operation below normal oil temperature (90 to 110 °C / 194 to 230 °F), as possible formation of condensation water in the lubrication system badly influences the oil quality. To evaporate possibly accumulated condensation water, at least once a day 100 °C (212 °F) oil temperature must be reached.

4.8) Engine shut-off

Normally the cooling down of the engine during descending and taxiing will be sufficient to allow the engine to be shut off as soon as the aircraft is stopped.

At increased operating temperatures make an engine cooling run of at least minimum 2 minutes.

4.9) Cold weather operation

Generally, an engine service should be carried out before the start of the cold season.

Coolant

For selection of coolant and mixing ratio, see [Chapter 2.3](#).

Lubricant

For selection of oil, see table of Lubricants [Chapter 2.5](#).

Cold start

- With throttle closed and choke activated (open throttle renders starting carb ineffective)
- Be aware, no spark below crankshaft speed of 220 rpm (propeller speed of 90 rpm)
- As performance of electric starter is greatly reduced when hot, limit starting to periods not much longer than 10 sec.
With a well charged battery, adding a second battery will not improve cold starts

Remedy - Cold start

Step	Procedure
1	Use of multigrade oil with the low end viscosity code of 5 or 10.
2	Check electrode gap of spark plugs and if worn fit new spark plugs. See Maintenance Manual Line (MML) of the respective engine type.
3	Preheat engine.

Icing in the air intake system

Icing due to humidity.

Carburetor icing due to humidity may occur on the venturi and on the throttle valve due to fuel evaporation and leads to performance loss and change in mixture.

Remedy

- Carburetor heat is the only effective remedy. See Flight Manual or other operating instructions regarding the carburetor heat supplied by the aircraft manufacturer.

Icing due to water fuel

Icing due to water in fuel.

NOTICE

Fuels containing alcohol always carry a small amount of water in solution. In case of temperature changes or increase of alcohol content, water or a mixture of alcohol and water may settle and could cause troubles.

Water in fuel will accumulate at the lower parts of the fuel system and leads to freezing of fuel lines, filters or jets.

Remedy

- Use non-contaminated fuel (filtered through suede)
- Generously sized water separators
- Fuel lines routing inclined and without undrained low points
- Prevent condensation of humidity, i. e avoid temperature differences between aircraft and fuel

**INTENTIONALLY LEFT
BLANK**

5) Performance and Fuel consumption

Topics in this chapter

5.1 Performance data	2
5.2 Fuel consumption	8

I Introduction

The performance tables and performance graphs on the next few pages are intended to show you what kind of performance to expect from your engine in terms of power output. The indicated power can be achieved by following the procedures laid out in the Operators Manual (OM) and ensuring that the engine is well-maintained.

5.1) Performance data

Performance graphs
Engine 912 A/F/UL

Performance graphs for stand. conditions (ISA)

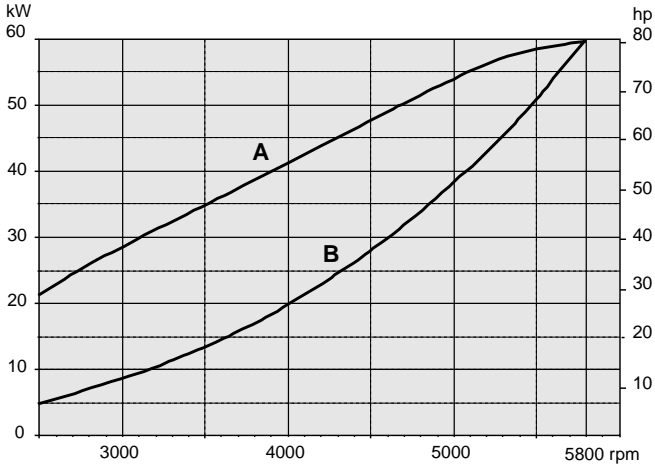

Figure 1: Performance graphs 912 A/F/UL

A max. engine output

B power requirement of propeller

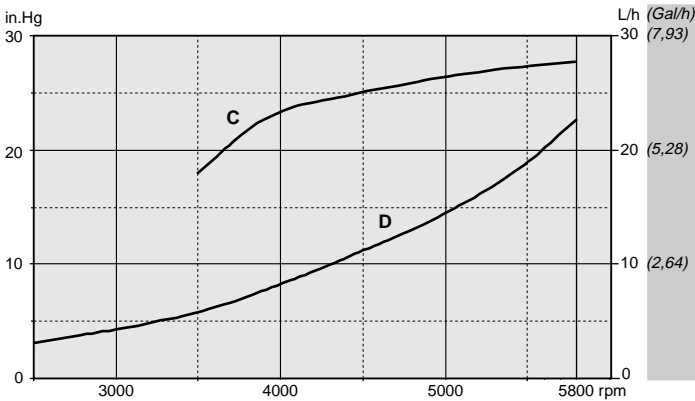

Figure 2: Values along propeller curve

C manifold pressure

D fuel consumption

**Performance data
Engine 912 A/F/UL**

Performance data for variable pitch propeller

Engine speed over 5500 rpm is restricted to 5 minutes.
Run the engine in accordance with the following table.

Power setting	Engine speed (rpm)	Performance (kW)/(HP)	Torque (Nm)/(ft. lb)	Manifold pressure (in. Hg)
Take-off power	5800	59.6 / 80	98.1 / 72.35	full throttle
max. continuous power	5500	58.0 / 78	100.7 / 74.27	full throttle
75 %	5000	43.5 / 58	83.1 / 61.29	27.2
65 %	4800	37.7 / 50	75.0 / 55.32	26.5
55 %	4300	31.9 / 43	70.8 / 52.22	26.3

NOTE

Further essential information regarding engine behavior see Service Letter SL-912-016, latest edition.

**Performance data
Engine 912 A/F/UL**

Performance data variable pitch propeller

The following graph shows the performance drop with increasing flight altitude. The curves show the performance at 5800, 5500, 5000, 4500 and 4000 rpm, at full throttle.

At deviation of temperature conditions from standard atmosphere conditions the engine performance to be expected can be calculated from the performance indicated, multiplied by standard temperature, divided by actual temperature in K.

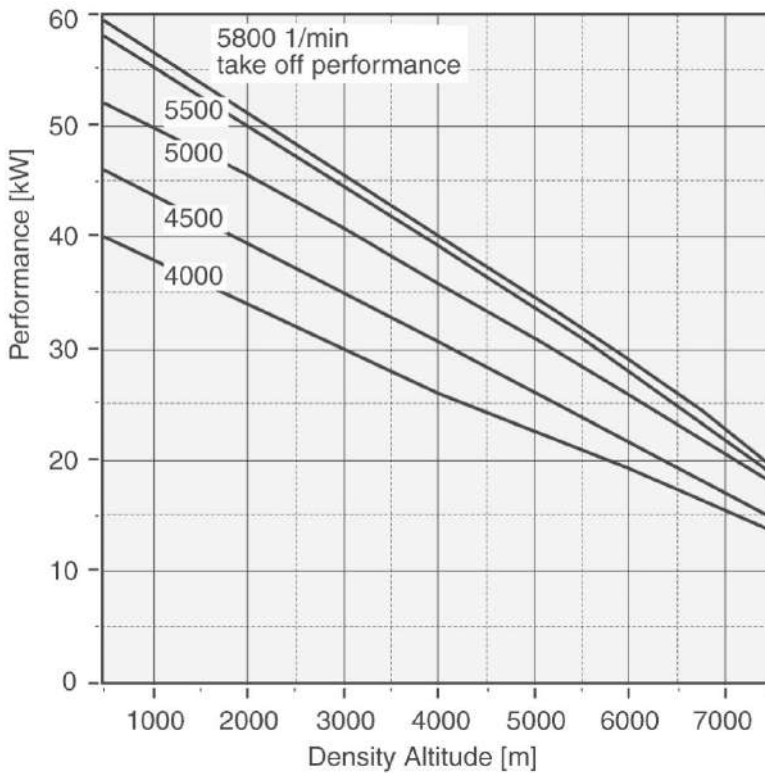

$$P_{\text{act.}} = P_{\text{stand.}} \frac{T_{\text{standard}}}{T_{\text{actually}}}$$

$$T \text{ [K]} = t \text{ [}^\circ\text{C]} + 273$$

Figure 3: Performance graphs 912 A/F/UL

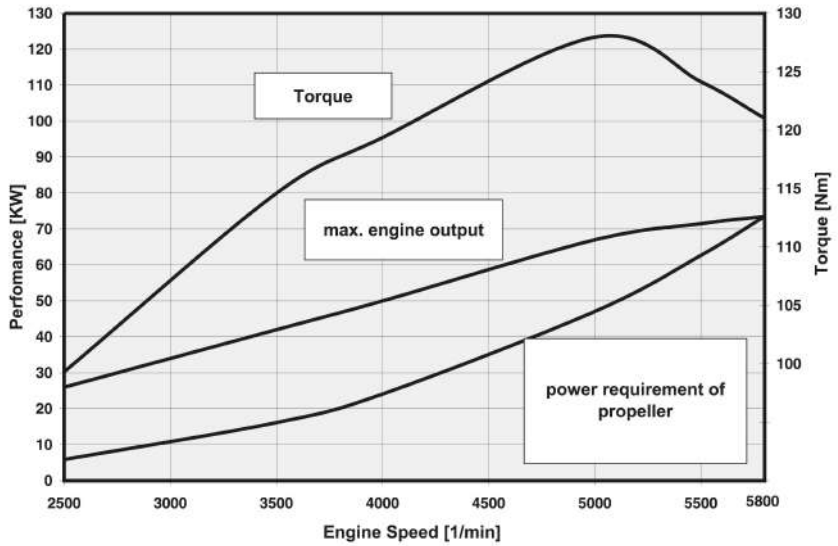

Figure 4: Performance graphs Engine 912 S/ULS

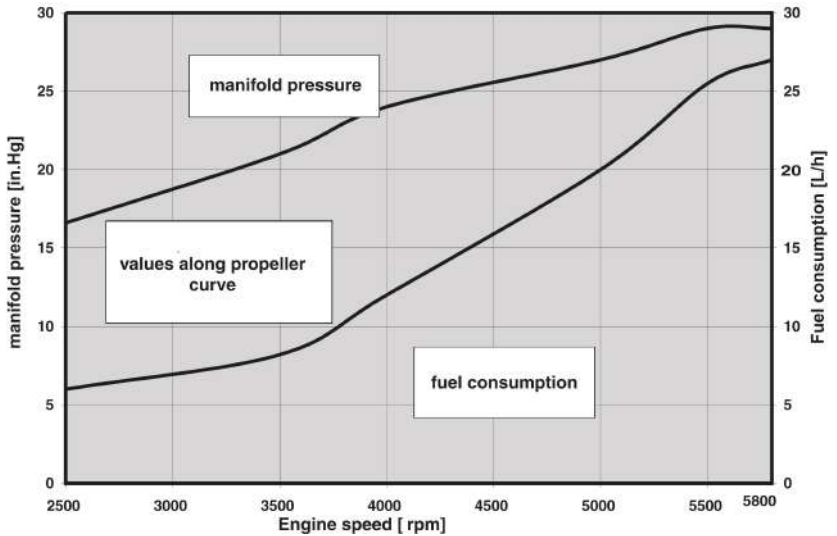

Figure 5: Performance graphs Motor 912 S/ULS

Performance data for variable pitch propeller

Engine speed over 5500 rpm is restricted to 5 minutes.
Run the engine in accordance with the following table.

Power setting	Engine speed (rpm)	Performance (kW) / (HP)	Torque (Nm) / (ft. lb)	Manifold pressure (in.Hg)
Take-off power	5800	73.5 / 100	121.0 / 89.24	27.5
Max. continuous power	5500	69.0 / 90	119.8 / 88.36	27
75 %	5000	51.0 / 68	97.4 / 71.84	26
65 %	4800	44.6 / 60	88.7 / 65.42	26
55 %	4300	38.0 / 50	84.3 / 62.17	24

NOTE

Further essential information regarding engine behavior see Service Letter SL-912-016, latest edition.

Performance graph for non standard conditions

The following graph shows the performance drop with increasing flight altitude. The curves show the performance at 5800, 5500, 5000, 4800 and 4300 rpm, at full throttle. At deviation of temperature conditions from standard atmosphere conditions the engine performance to be expected can be calculated from the performance indicated, multiplied by standard temperature, divided by actual temperature in °K.

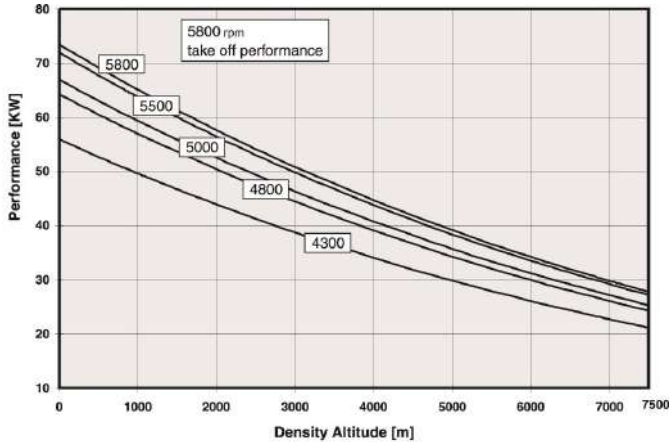

$$P_{act.} = P_{stand.} \cdot \frac{T_{standard}}{T_{actually}}$$

$$T [K] = t [^{\circ}C] + 273$$

Figure 6: Performance graph

5.2) Fuel consumption

Fuel consumption	912 A/F/UL	912 S/ULS
At take-off performance	24.0 l/h (6.3 gal/h)	27.0 l/h (7.1 gal/h)
At max. continuous performance	22.6 l/h (5.6 gal/h)	25.0 l/h (6.6 gal/h)
At 75 % continuous performance	16.2 l/h (4.3 gal/h)	18.5 l/h (4.9 gal/h)
Specific consumption at max. continuous performance	285 g/kWh (0.47 lb/hph)	285 g/kWh (0.47 lb/hph)

7) System Description

Topics in this chapter

7.1 General specification	2
7.1.1 Basic specification	2
7.1.2 Technical data	2
7.1.3 Engine components.....	3
7.1.4 Cylinder arrangement	3
7.1.5 Direction of rotation	4
7.2 Cooling system	5
7.3 Fuel system	6
7.4 Lubrication system	7
7.5 Electric system	8
7.6 Propeller gearbox	9

Introduction

This chapter of the Operators Manual (OM) contains information about the general engine specification as well as a description of cooling system, fuel system, lubrication system, electric system and the propeller gearbox.

The system description refers only to the engine and not to a specific application in a particular aircraft. The aircraft manufacturer's Operators Manual (OM) is therefore definitive in terms of the operation of the engine, as it contains all the aircraft specific instructions.

The design shown in this chapter does not represent a specified execution but should support the understanding of the system.

7.1) General specification

7.1.1) Basic specification

- 4 stroke, 4 cyl. horizontally opposed, spark ignition engine, single central camshaft hydraulic tappets - push rods - OHV (Over Head Valve)
- Liquid cooled cylinder heads
- Ram air cooled cylinders
- Dry sump forced lubrication
- Dual ignition of breakerless, capacitor discharge design
- 2 constant depression carburetors
- Mechanical fuel pump
- Electric starter (12 V 0.7 kW), 912 S/ULS (12 V 0.9 kW)
- Integrated AC generator with external rectifier regulator
- Propeller drive via integrated gearbox with mechanical shock absorber and overload clutch

NOTE

The overload clutch is installed on all serial production aircraft engines which are certified and non-certified aircraft engines of the configuration 3.

Optional

- Electric starter (12 V 0.9 kW)
- External alternator (12 V 40 A DC)
- Vacuum pump drive
- Hydraulic constant speed propeller governor drive

7.1.2) Technical data

Description	912 A/F/UL	912 S/ULS
Bore	79.5 mm (3.13 in)	84 mm (3.31 in)
Stroke	61 mm (2.40 in)	61 mm (2.40 in)
Displacement	1211 cm ³ (73.9 in ³)	1352 cm ³ (82.5 in ³)
Compression ratio.	9.0 : 1	10.8 : 1

7.1.3) Engine components

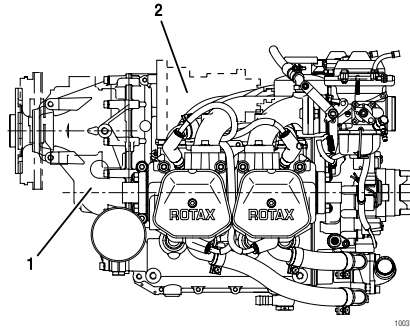

Figure 1: Engine components

- | | |
|-----------------------------|---|
| <p>1 Propeller gear box</p> | <p>2 Vacuum pump or hydraulic governor for constant speed propeller</p> |
|-----------------------------|---|

7.1.4) Cylinder arrangement

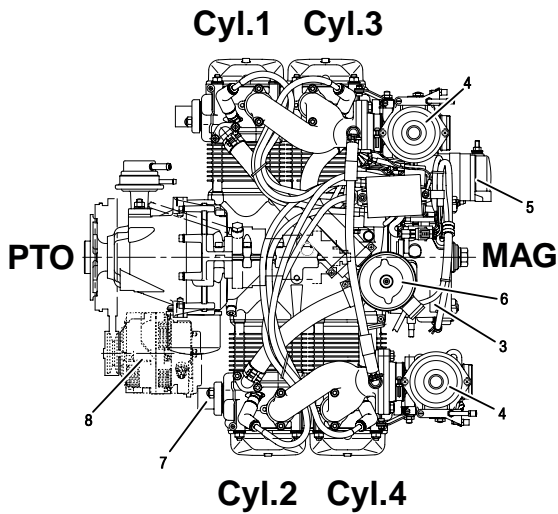

Figure 2: Cylinder arrangement

7.1.5) Direction of rotation

Direction of rotation on propeller shaft: counter clockwise, viewed from the front.

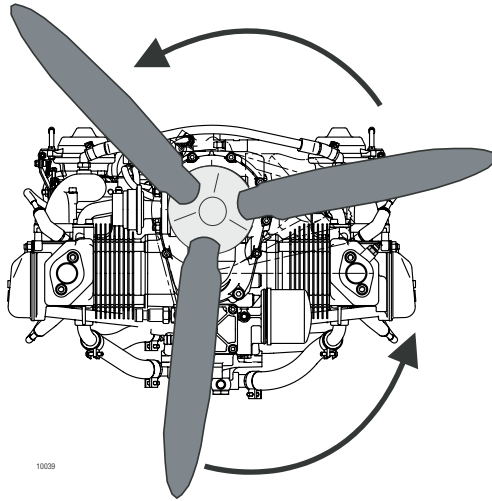

Figure 3: Normal direction of propeller rotation (engine)

7.2) Cooling system

System Overview

The cooling system of the engine is designed for liquid cooling of the cylinder heads and ram-air cooling of the cylinders. The cooling system of the cylinder heads is a closed circuit with an expansion tank.

Coolant flow

The coolant flow is forced by a water pump, driven from the camshaft, from the radiator to the cylinder heads. From the top of the cylinder heads the coolant passes on to the expansion tank. Since the standard location of the radiator is below engine level, the expansion tank located on the top of the engine allows for coolant expansion.

Expansion tank

From the expansion tank the coolant is sucked back to the water pump. In common installations the coolant passes a radiator in between. Additionally the expansion tank is closed by a pressure cap (with excess pressure valve and return valve). At temperature rise of the coolant the excess pressure valve opens and the coolant will escape via hose at atmospheric pressure. In common installation this hose is connected to an overflow bottle. This overflow bottle allows the coolant to be sucked back into the cooling circuit as the engine is cooling down.

NOTE

The coolant temperature sensors are located in cylinder head 2 and 3.

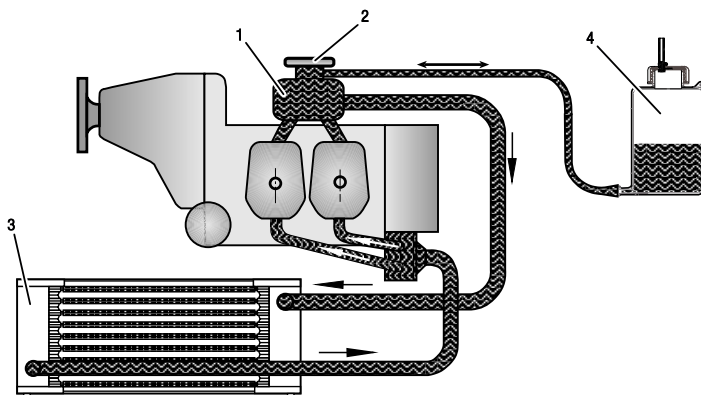

09152

Figure 4: Cooling system (symbolic)

- | | | | |
|---|----------------|---|-----------------|
| 1 | Expansion tank | 2 | Pressure cap |
| 3 | Radiator | 4 | Overflow bottle |

7.3) Fuel system

- Fuel** The fuel flows from the tank via a coarse filter the fire cock and fine filter to the mechanical fuel pump. From the pump fuel passes on via the fuel manifold to the two carburetors.
- Return line** Via the return line surplus fuel flows back to the fuel tank and suction side of fuel system.

NOTE

The return line serves to avoid formation of vapor lock.

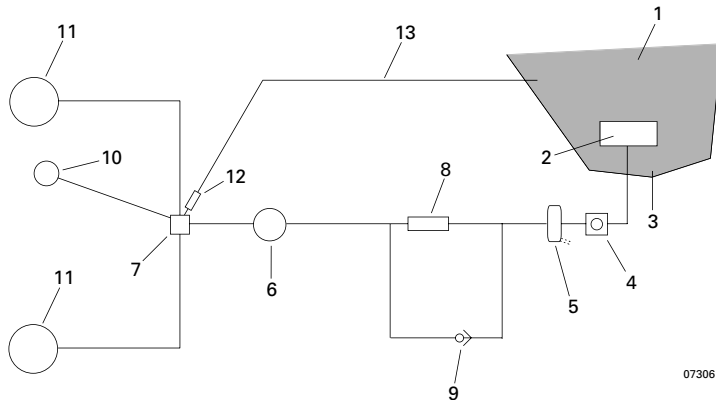

- | | |
|--|---|
| 1 Fuel tank | 2 Coarse filter |
| 3 Drain valve | 4 Fire cock |
| 5 Fine filter/water trap | 6 Mechanical fuel pump (standard configuration) |
| 7 Fuel manifold (not standard configuration) | 8 Electrical fuel pump |
| 9 1x check valve | 10 Fuel pressure gauge |
| 11 Carburetor | 12 Restrictor jet |
| 13 Return line from engine to tank | |

Figure 5: Fuel system

7.4) Lubrication system

The engines is provided with a dry sump forced lubrication system with a main oil pump with integrated pressure regulator. The airframe manufacturer is responsible for the main layout and the component selection for the lubrication system.

Lubrication

The main oil pump sucks the motor oil from the oil tank via oil radiator and forces it through the oil filter to the points of lubrication.

NOTE

The oil radiator is optional.

Crankcase

The surplus of oil emerging from the points of lubrication accumulates on the bottom of crankcase and is forced back to the oil tank by the piston blow-by gases.

Oil pump

The oil pump is driven by the camshaft.

Oil circuit vented

The oil circuit is vented via bore on the oil tank.

Oil temperature sensor

The oil temperature sensor for reading of the oil inlet temperature is located on the oil pump housing.

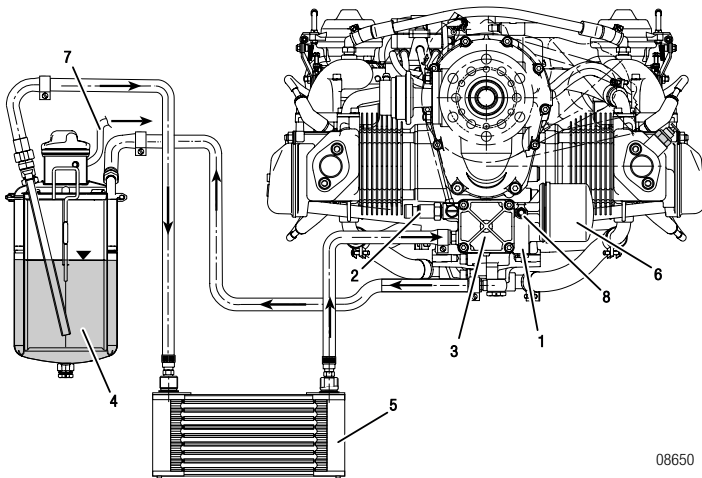

08650

Figure 6: Lubrication system

- | | | | |
|---|--------------------|---|------------------------------|
| 1 | Pressure regulator | 2 | Oil pressure sensor |
| 3 | Oil pump | 4 | Oil tank |
| 5 | Oil radiator | 6 | Oil filter |
| 7 | Venting tube | 8 | Oil temperature sensor (oil) |

7.5) Electric system

The ROTAX® 912 engine is equipped with a dual ignition unit of a breakless, capacitor discharge design, with an integrated generator.

The ignition unit needs no external power supply.

Charging coils

Two independent charging coils located on the generator stator supply one ignition circuit each. The energy is stored in capacitors of the electronic modules. At the moment of ignition 2 each of the 4 external trigger coils actuate the discharge of the capacitors via the primary circuit of the dual ignition coils.

NOTE

An additional trigger coil is provided for rev counter signal.

Firing order: 1 - 4 - 2 - 3

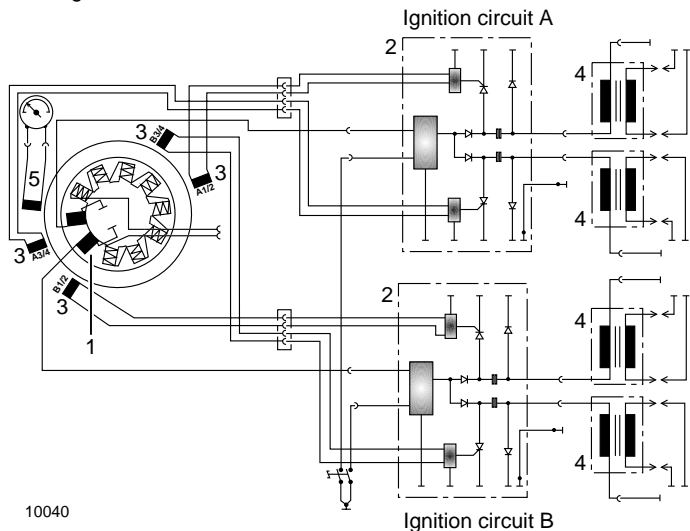

- | | | | |
|---|-----------------------------------|---|---------------------|
| 1 | Charging coils | 2 | Electronic modules |
| 3 | Trigger coils for ignition signal | 4 | Dual ignition coils |
| 5 | Trigger coil for speed signal | | |

Figure 7: Ignition circuit

7.6) Propeller gearbox

Reduction ratio

For the engine type 912 one reduction ratio is available.

Reduction ratio	912 A/F/UL	912 S/ULS
crankshaft: propeller shaft	2.27:1	2.43:1
	2.43:1 (option)	

Overload clutch

Depending on engine type, certification and configuration the propeller gearbox is supplied with or without an overload clutch.

NOTE

This overload clutch will prevent any undue load to the crankshaft in case of ground contact of the propeller.

NOTE

The overload clutch is installed on serial production on all certified aircraft engines and on the non-certified aircraft engines of configuration 3.

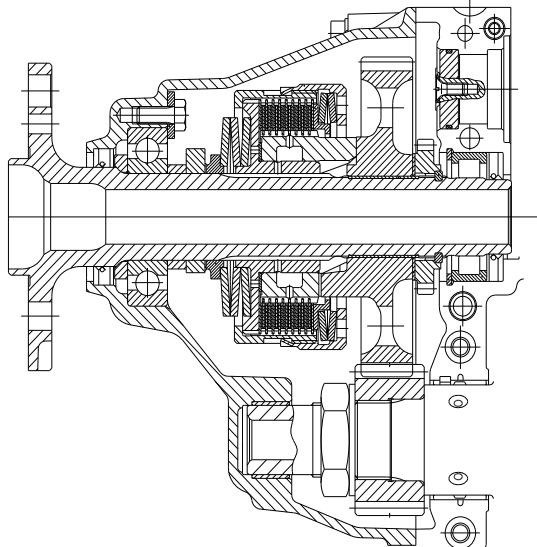

Figure 8: Overload clutch

Fig. shows a propeller gearbox of configuration 2 with the integrated overload clutch.

Torsional shock absorber

The design incorporates a torsional shock absorber. The shock absorbing is based on progressive torsional cushioning due to axial spring load acting on a dog hub.

Backlash

On the gearbox version with overload clutch the design incorporates a friction damped free play at the dogs to warrant proper engine idling. Due to this backlash at the dogs a distinct torsional impact arises at start, stop and at sudden load changes, but due to the built-in overload clutch it will remain harmless.

NOTE

This overload clutch will also prevent any undue load to the crankshaft in case of ground contact of the propeller.

See Service Letter SL-912-015

Vacuum pump or hydraulic governor

Alternatively either a vacuum pump or a hydraulic governor for constant speed propeller can be used. The drive is in each case via the propeller reduction gear.

8) Preservation and storage

Topics in this chapter

8.1 Engine preservation and storage	2
8.2 Engine back to operation	3

Safety

All checks to be carried out as specified in the current Maintenance Manual Line (MML) (last revision).



As well as the maintenance and special checks, see Maintenance Manual Line (MML) for the engine type 912.

⚠ WARNING

Non-compliance can result in serious injuries or death!

Only qualified staff (authorized by the Aviation Authorities) trained on this particular engine, is allowed to carry out maintenance and repair work.

NOTE

Other useful information for service and airworthiness of your engine you'll find on

www.rotax-owner.com.

NOTICE

Carry out all directives of Service Bulletins (SB), according to their priority. Observe applicable Service Instructions (SI) and Service Letter (SL).

8.1) Engine preservation and storage

General

Environmental corrosion (on the external surfaces) is a naturally occurring process which can inevitably affect the continued airworthiness of the engine, engine mounted components and accessories. Susceptibility to corrosion is influenced by a number of factors, including but not limited to, geographical location, season and usage. All general preventive (technical) measures, identification, control and treatment of corrosive attack on aircraft structures and engine materials has to be carried out in accordance with Advisory Circular AC 43-4B from FAA and also in accordance with the information of the aircraft manufacturer's Instruction for Continued Airworthiness. Furthermore the preservation procedures for stored and inactive aircraft (engines) provides an effective means for combating and minimizing the corrosion condition and should be adhered to.

Advisory Circular AC 43-4B: This advisory circular (AC) is a summary of the current available data regarding identification and treatment of corrosive attack on aircraft structures and engine materials. Corrosion inspection frequency, corrosion identification, and especially corrosion treatment continues to be the responsibility of the operator. These inspections should be accomplished per this AC, the manufacturer's recommendations, or the operator's own maintenance program. The procedures in this AC are an acceptable means, but not the only acceptable means, of corrosion treatment. The information in this AC is applicable to aircraft for which the manufacturer has not published corrosion control information.

WARNING

Risk of burns and scalds! Hot engine parts!
Conduct checks on cold engine only!

Due to the special material of the cylinder wall, there is no need for extra protection against corrosion for ROTAX® aircraft engines. At extreme climatic conditions and/or for long out of service periods we recommend the following to protect the valve guides against corrosion:

Step	Procedure
1	Operate the engine until the temperatures have stabilized for a period of 5 min. (engine oil temperature between 50 to 70 °C (122 to 160 °F)).
2	Shut-off engine.
3	Allow the engine to cool down.

Step	Procedure
4	Change oil.
5	Remove the top spark plugs and spray into openings with corrosion inhibiting oil.
6	Turn the propeller several times by hand in direction of the engine rotation, so that the corrosion inhibiting oil reaches all necessary points.
7	Install the spark plugs in accordance to the Maintenance Manual.
8	Close all openings on the cold engine, such as exhaust end pipe, venting tube, air filter etc. against entry of dirt and humidity.
9	Spray all steel external engine parts with corrosion inhibiting oil. Drain carburetor float chambers.

8.2) Engine back to operation

If preservation (including oil change) took place within a year of storage, oil renewal will not be necessary. For longer storage periods repeat preservation annually.

Step	Procedure
1	Remove all plugs and caps.
2	Clean spark plugs with plastic brush and solvent.
3	Reinstall.

**INTENTIONALLY LEFT
BLANK**

9) Supplement

Topics in this chapter

9.1 Form	2
----------------	---

See [Form](#).

According to the regulation of EASA part 21.A.3 the manufacturer shall evaluate field information and report to the authority. In case of any relevant occurrences that may involve malfunction of the engine, the form on the next page should be filled out and sent to the responsible ROTAX® authorized aircraft engines distributor or their independent Service Center.

NOTE

The form is also available from the official ROTAX® AIRCRAFT ENGINES Website in electronic version.

Authorized Distributor

Overview of ROTAX® authorized aircraft engines distributor or their independent Service Center.

Refer to the official ROTAX® AIRCRAFT ENGINES Website www.FLYROTAX.com.

9.1) Form

ROTAX.

CUSTOMER SERVICE INFORMATION REPORT

WHEN / WHERE / WHAT

Accident / Incident Date _____ State / Country _____

Location of Occurrence _____

Headline _____

Narrative

AIRCRAFT IDENTIFICATION

Aircraft registration _____ Aircraft category _____

Manufacturer _____ Model / Series _____

Serial Number _____ Aircraft total time _____

FLIGHT DETAILS

Flight phase _____ Operator _____

Last departure point _____ Planned destination _____

ENGINE INFORMATION

Type _____ Serial Number _____

Time since new [h] _____ Time since overhaul [h] _____

Date overhaul _____ Date inspection / maintenance _____

PROPELLER INFORMATION

Manufacturer _____ Model / Series _____

Serial Number _____ Propeller position _____

FLYROTAX.COM

* and TM are Trademarks of BRP-Rotax GmbH & Co KG.
© 2020 BRP-Rotax GmbH & Co KG. All rights reserved

EASAZJJ048



Figure 1: Form

Index

A

Abbreviations	3
Abnormal operation.....	1
After engine start	8

B

Basic specification	2
Before engine start.....	5

C

Cold weather operation	10
Cooling system	5
Cruising	9
cylinder arrangement	3

D

Daily checks	2
Direction of rotation	4

E

Electric system	8
Engine back to operation	3
Engine components	3
Engine preservation and storage.....	2
Engine shut-off	10
Engine start.....	5–6
Exceeding cylinder head temperature	3
Exceeding engine speed	3
Exceeding of max. admissible coolant temperature	4
Exceeding of max. admissible cooling system temperature	3
Exceeding oil temperature	4

F

Fire, Engine, compartment	5
Form.....	2
Fuel consumption	8
Fuel system.....	6

G

General.....	2
General specification.....	2

L

List of effective pages.....	1
Lubrication system	7

O

Oil pressure.....	4–5
Oil pressure below minimum - on ground	5
Operating limits (912 A/F/UL).....	2
Operating limits(912 S/ULS)	5
Operating media Fuel.....	10
Operating media-Coolant	9
Operating media-Lubricants.....	11

P

Performance data	2
Pre-flight checks	5
Propeller gearbox	9

R

Re-Start during flight	3
------------------------------	---

S		Take-off.....9
Safety notice	8, 10	Technical data2
Start.....	9	Technical documentation 13
		Temperature3
		Terms3
T		Trouble shooting6
Table of amendments.....	1	Type description 912 Series..... 15

ROTAX®



ORIGINAL TRUST
**ROTAX
GENUINE
PARTS**
ORIGINAL QUALITY
ORIGINAL VALUE

**DON'T SETTLE
FOR LESS.**



**IN A WORLD
FULL OF FAKES,
STAY ORIGINAL.**

GENUINE PARTS

ORIGINAL QUALITY. ORIGINAL VALUE. ORIGINAL TRUST.

The high levels of safety, reliability, and performance you decided on when choosing your aircraft engine are also reflected in every single part they are built of. Find your extra peace of mind by using only Rotax Genuine Parts when your engine is serviced.

Rotax Genuine Parts are manufactured to strict quality standards for an exact fit and precise operation. They ensure that your aircraft will continue to perform at maximum levels with minimum downtime and a long service life.

Rotax Genuine Parts meet Design/Production Organisation Approval (DOA/POA) and quality standards (EASA/ASTM).

All Rotax Genuine Parts come with a coverage for the first 24 consecutive months or the first 100 hours of operation, whichever occurs first.

**There is no Rotax warranty on non-genuine parts.
If a non-genuine part causes an event on a Rotax engine,
it may nullify any warranty.**

* applies to all Rotax engine series except Rotax 582 UL

** This offer only applies if allowed under the applicable law. Some jurisdictions may not allow, or may limit, the validity of some or part of the offer; therefore conditions may vary or not be available in some locations. For more details ask your local distributor.

ROTAX®



Engine serial no.

Type of aircraft

Aircraft registration no.

Rotax® authorized distributor



FLYROTAX.COM

® and TM are Trademarks of BRP-Rotax GmbH & Co KG.

© 2023 BRP-Rotax GmbH & Co KG. All rights reserved.

