

ROTAX®

915 iS

ROTAX

MAINTENANCE MANUAL LINE

FOR ROTAX ENGINE TYPE 915 i A / C24 SERIES
REF NO.: MML-915 i A / C24 | PART NO.: 898863



WARNING

Before starting any maintenance work, please read the Maintenance Manual completely as it contains important safety relevant information. Failure to do so may result in personal injuries including death. Consult the original equipment manufacturers handbook for additional instructions!

These technical data and the information embodied therein are the property of BRP-Rotax GmbH & CO KG, Austria, acc, BGBl 1984 no. 448, and shall not, without prior written permission of BRP-Rotax GmbH & Co KG, be disclosed in whole or in part to third parties. This legend shall be included on any reproduction of these data, in whole or in part. The Manual must remain with the engine/aircraft in case of sale.

ROTAX® is a trade mark of BRP-Rotax GmbH & Co KG. In the following document the short form of BRP-Rotax GmbH & Co KG = BRP-Rotax is used.

Other product names in this documentation are used purely for ease of identification and may be trademarks of the respective company or owner.

Copyright 2025 © - all rights reserved.

Translation into other languages might be performed in the course of language localization but does not lie within ROTAX® scope of responsibility.

In any case the original text in English language and the metric units are authoritative.

BRP-Rotax
MAINTENANCE MANUAL LINE

Table of Content

Chapter	INTRO – GENERAL NOTE
Chapter	LEP – LIST OF EFFECTIVE PAGES
Chapter	TOA – TABLE OF AMENDMENTS
Chapter	00–00–00 – GENERAL NOTE
Chapter	04–00–00 – AIRWORTHINESS LIMITATIONS
Chapter	05–00–00 – MAINTENANCE
Chapter	05–10–00 – TIME LIMITS
Chapter	05–20–00 – SCHEDULED MAINTENANCE CHECKS
Chapter	05–50–00 – UNSCHEDULED MAINTENANCE CHECKS
Chapter	12–00–00 – MAINTENANCE OF THE SYSTEMS
Chapter	12–10–00 – REPLENISHING OPERATING FLUIDS
Chapter	12–20–00 – SCHEDULED MAINTENANCE

BRP-Rotax
MAINTENANCE MANUAL LINE

INTENTIONALLY LEFT
BLANK

BRP-Rotax
MAINTENANCE MANUAL LINE

Chapter: INTRO
GENERAL NOTE

Foreword

Before carrying out maintenance work on the engine, read this Maintenance Manual carefully.

If any passages of the Manual are not clearly understood or in case of any questions, please contact your nearest ROTAX® Authorized Aircraft Engines Distributors or their independent Service Centers.

BRP-Rotax wishes you much pleasure and satisfaction flying your aircraft powered by this ROTAX®-aircraft engine.

The structure of the Manual follows whenever it is possible the structure of the ATA (Air Transport Association) standards. The aim is the compatibility with the aircraft manufacturers documentation, which means they must then adapt the documentation to their standard.

BRP-Rotax
MAINTENANCE MANUAL LINE

INTENTIONALLY LEFT
BLANK

**BRP-Rotax
MAINTENANCE MANUAL LINE**

**Chapter: LEP
LIST OF EFFECTIVE PAGES**

Each new revision to the Maintenance Manual Line will have a new List of Effective Pages.

chapter	page	date
	Cover page	
INTRO	1	May 01 2025
	2	May 01 2025
LEP	1	May 01 2025
	2	May 01 2025
	3	May 01 2025
	4	May 01 2025
TOA	1	May 01 2025
	2	May 01 2025
	3	May 01 2025
	4	May 01 2025
00-00-00	1	May 01 2025
	2	May 01 2025
	3	May 01 2025
	4	May 01 2025
	5	May 01 2025
	6	May 01 2025
	7	May 01 2025
	8	May 01 2025
	9	May 01 2025
	10	May 01 2025
	11	May 01 2025
	12	May 01 2025
	13	May 01 2025
	14	May 01 2025
	15	May 01 2025

chapter	page	date
	16	May 01 2025
	17	May 01 2025
	18	May 01 2025
04-00-00	1	May 01 2025
	2	May 01 2025
05-00-00	1	May 01 2025
	2	May 01 2025
	3	May 01 2025
	4	May 01 2025
	5	May 01 2025
	6	May 01 2025
	7	May 01 2025
	8	May 01 2025
	9	May 01 2025
	10	May 01 2025
	11	May 01 2025
	12	May 01 2025
	13	May 01 2025
	14	May 01 2025
05-10-00	1	May 01 2025
	2	May 01 2025
	3	May 01 2025
	4	May 01 2025
	5	May 01 2025
	6	May 01 2025
	7	May 01 2025

BRP-Rotax
MAINTENANCE MANUAL LINE

chapter	page	date
05-20-00	8	May 01 2025
	1	May 01 2025
	2	May 01 2025
	3	May 01 2025
	4	May 01 2025
	5	May 01 2025
	6	May 01 2025
	7	May 01 2025
	8	May 01 2025
	9	May 01 2025
	10	May 01 2025
	11	May 01 2025
	12	May 01 2025
	13	May 01 2025
	14	May 01 2025
	15	May 01 2025
	16	May 01 2025
	05-50-00	17
18		May 01 2025
1		May 01 2025
2		May 01 2025
3		May 01 2025
4		May 01 2025
5		May 01 2025
6		May 01 2025
7		May 01 2025
8		May 01 2025
9		May 01 2025
10	May 01 2025	
11	May 01 2025	

chapter	page	date
	12	May 01 2025
	13	May 01 2025
	14	May 01 2025
	15	May 01 2025
	16	May 01 2025
	17	May 01 2025
	18	May 01 2025
	19	May 01 2025
	20	May 01 2025
	21	May 01 2025
	22	May 01 2025
	23	May 01 2025
	24	May 01 2025
	25	May 01 2025
	26	May 01 2025
	27	May 01 2025
	28	May 01 2025
	29	May 01 2025
	30	May 01 2025
	31	May 01 2025
	32	May 01 2025
	33	May 01 2025
	34	May 01 2025
	35	May 01 2025
	36	May 01 2025
	37	May 01 2025
	38	May 01 2025
	39	May 01 2025
	40	May 01 2025
	41	May 01 2025

BRP-Rotax
MAINTENANCE MANUAL LINE

chapter	page	date
	42	May 01 2025
	43	May 01 2025
	44	May 01 2025
	45	May 01 2025
	46	May 01 2025
12-00-00	1	May 01 2025
	2	May 01 2025
12-10-00	1	May 01 2025
	2	May 01 2025
	3	May 01 2025
	4	May 01 2025
	5	May 01 2025
	6	May 01 2025
	7	May 01 2025
	8	May 01 2025
	9	May 01 2025
	10	May 01 2025
12-20-00	1	May 01 2025
	2	May 01 2025
	3	May 01 2025
	4	May 01 2025
	5	May 01 2025
	6	May 01 2025
	7	May 01 2025
	8	May 01 2025
	9	May 01 2025
	10	May 01 2025
	11	May 01 2025
	12	May 01 2025
	13	May 01 2025

chapter	page	date
	14	May 01 2025
	15	May 01 2025
	16	May 01 2025
	17	May 01 2025
	18	May 01 2025
	19	May 01 2025
	20	May 01 2025
	21	May 01 2025
	22	May 01 2025
	23	May 01 2025
	24	May 01 2025
	25	May 01 2025
	26	May 01 2025
	27	May 01 2025
	28	May 01 2025
	29	May 01 2025
	30	May 01 2025
	31	May 01 2025
	32	May 01 2025
	33	May 01 2025
	34	May 01 2025
	35	May 01 2025
	36	May 01 2025
	37	May 01 2025
	38	May 01 2025
	39	May 01 2025
	40	May 01 2025
	41	May 01 2025
	42	May 01 2025
	43	May 01 2025

BRP-Rotax
MAINTENANCE MANUAL LINE

chapter	page	date
	44	May 01 2025
	45	May 01 2025
	46	May 01 2025
	47	May 01 2025
	48	May 01 2025
	49	May 01 2025
	50	May 01 2025
	51	May 01 2025

chapter	page	date
	52	May 01 2025
	53	May 01 2025
	54	May 01 2025
	55	May 01 2025
	56	May 01 2025
	Index	May 01 2025
	Rear page	

BRP-Rotax
MAINTENANCE MANUAL LINE

Chapter: TOA
TABLE OF AMENDMENTS

Approval*

The technical content of this document is approved under the authority of the DOA ref. EASA.21J.048.

NOTE

THE APPROVAL IS GIVEN TO ALL CHAPTERS EXCEPT THE AIRWORTHINESS LIMITATIONS SECTION 04-00-00 WHICH IS SUBJECT TO SPECIFIC APPROVAL OF THE EASA.

Edition 0/Rev. 0 December 01 2017

Rev. 1 June 01 2019

Rev. 2 July 01 2021

Obsolete with Revision 3, which is a complete revision

Rev. 3 May 01 2025

Rev. no.	chapter	page	date of change	remark for approval	date of approval from authorities	date of inclusion	signature
0	INTRO	all	Dec. 01 2017	DOA*			
0	LEP	all	Dec. 01 2017	DOA*			
0	TOA	all	Dec. 01 2017	DOA*			
0	00-00-00	all	Dec. 01 2017	DOA*			
0	04-00-00	all	Dec. 01 2017	EASA approved			
0	05-00-00	all	Dec. 01 2017	DOA*			
0	05-10-00	all	Dec. 01 2017	DOA*			
0	05-20-00	all	Dec. 01 2017	DOA*			
0	05-50-00	all	Dec. 01 2017	DOA*			
0	12-00-00	all	Dec. 01 2017	DOA*			
0	12-10-00	all	Dec. 01 2017	DOA*			
0	12-20-00	all	Dec. 01 2017	DOA*			

BRP-Rotax
MAINTENANCE MANUAL LINE

Rev. no.	chapter	page	date of change	remark for approval	date of approval from authorities	date of inclusion	signature
1	LEP	all	June 01 2019	DOA*			
1	TOA	all	June 01 2019	DOA*			
1	00-00-00	7, 12, 14	June 01 2019	DOA*			

Rev. no.	chapter	page	date of change	remark for approval	date of approval from authorities	date of inclusion	signature
1	05-00-00	4,6 - 10	June 01 2019	DOA*			
1	05-10-00	3	June 01 2019	DOA*			
1	05-20-00	2, 6, 8-13	June 01 2019 June 01 2019	DOA* DOA*			
1	05-50-00	2,4,6,10, 13, 26,27,33	June 01 2019 June 01 2019 June 01 2019	DOA* DOA* DOA*			
1	12-10-00	3	June 01 2019	DOA*			
1	12-20-00	9,14,15,- 25,30, 31,35,41, 44-46	June 01 2019 June 01 2019 June 01 2019 June 01 2019	DOA* DOA* DOA* DOA*			

Rev. no.	chapter	page	date of change	remark for approval	date of approval from authorities	date of inclusion	signature
2	LEP	all	July 01 2021	DOA*			
2	TOA	all	July 01 2021	DOA*			
2	05-00-00	2,3,9,12	July 01 2021	DOA*			
2	05-20-00	8,9,13	July 01 2021	DOA*			
2	05-50-00	8-11, 21, 22,24,26, 31,35,42, 44	July 01 2021 July 01 2021 July 01 2021 July 01 2021	DOA* DOA* DOA* DOA*			

BRP-Rotax
MAINTENANCE MANUAL LINE

Rev. no.	chapter	page	date of change	remark for approval	date of approval from authorities	date of inclusion	signature
2	12-10-00	5,7	July 01 2021	DOA*			
2	12-20-00	6,8,19, 24,30,32 33,43, 51.52	July 01 2021 July 01 2021 July 01 2021 July 01 2021	DOA* DOA* DOA* DOA*			

Rev. no.	chapter	page	date of change	remark for approval	date of approval from authorities	date of inclusion	signature
3	LEP	all	May 01 2025	DOA*			
3	TOA	all	May 01 2025	DOA*			
3	00-00-00	14	May 01 2025	DOA*			
3	05-00-00	4,8-11	May 01 2025	DOA*			
3	05-10-00	4,5	May 01 2025	DOA*			
3	05-20-00	8-16	May 01 2025	DOA*			
3	05-50-00	2,6-12, 14,16,18 21-26,38 42,45	May 01 2025 May 01 2025 May 01 2025 May 01 2025	DOA* DOA* DOA* DOA*			
3	12-20-00	3,10-17, 23,30, 33-35,37, 38,43-46 53,54	May 01 2025 May 01 2025 May 01 2025 May 01 2025 May 01 2025	DOA* DOA* DOA* DOA* DOA*			

BRP-Rotax MAINTENANCE MANUAL LINE

Summary of amendments

Summary of the relevant amendments in this context, but without requirement on completeness.

Rev. no.	chapter	page	date of change	comment
1	00-00-00	7	June 01 2019	New: Wiring color code
1	00-00-00	14	June 01 2019	change of text
1	05-20-00	2, 6	June 01 2019	change of table
1	05-20-00	8-13	June 01 2019	change of table
1	05-50-00	6	June 01 2019	Warning: change of text
1	05-50-00	33	June 01 2019	change of text
1	12-20-00	30, 31	June 01 2019	change of text, new figure
1	12-20-00	44, 45	June 01 2019	New: Checking and cleaning plug screw (turbo oil sump assy.)

Rev. no.	chapter	page	date of change	comment
2	05-00-00	2,3,9	July 01 2021	New text
2	05-00-00	8	July 01 2021	Consumable materials: PU-Glue removed
2	05-20-00	9	July 01 2021	change of text
2	05-50-00	2, 25	July 01 2021	change of text
2	05-50-00	26-31	July 01 2021	New: Checking of the cooling system/
2	12-20-00	8, 29	July 01 2021	radiator cap New text, new tool

Rev. no.	chapter	page	date of change	comment
3	05-20-00	8-16	May 01 2025	Maintenance schedule changed
3	05-50-00	22-24	May 01 2025	Exceeding of max. permissible RPM: new parameters
3	12-20-00	8-12	May 01 2025	Differential pressure method: new values, crankcase pressure check added
3	all other	marked	May 01 2025	text and figure correction

BRP-Rotax
MAINTENANCE MANUAL LINE

Chapter: 00-00-00
GENERAL NOTE

TOPICS IN THIS CHAPTER

General	2
Abbreviations and terms (depending on respective engine type)	3
Wiring color codes	8
Conversion table	9
Safety notice	10
Safety information	11
Instruction	13
Maintenance Concept.....	14
Technical documentation.....	15
Use for intended purpose	17

BRP-Rotax MAINTENANCE MANUAL LINE

GENERAL

Purpose

The purpose of this Manual is to provide aircraft manufacturers with technical requirements (e.g. interface descriptions and limitations) that must be adhered to when installing this type of engine into an aircraft or certifying aircraft powered by this engine type. Furthermore it should allow independent ROTAX® Maintenance Technicians (iRMT) to install this engine into an airframe in compliance with the relevant installation and safety instructions provided by the engine manufacturer.

For detailed information related to aircraft and aircraft/engine installation, maintenance, safety or flight operation, consult the documentation provided by the aircraft manufacturer and/or its dealer.

For additional information on engines, its maintenance or parts, you can also contact your nearest ROTAX® authorized Aircraft Engine Distributor or their independent Service Center.

ROTAX Distributors

For ROTAX® Authorized Distributors for aircraft engines see latest Operators Manual or the official website www.FLYROTAX.com.

Engine serial number

When making inquiries or ordering parts, always indicate the engine serial number. Due to continuous product improvement, engines of the same engine type might require different support and spare parts.

The engine serial number is on top of the crankcase, behind the propeller gearbox.

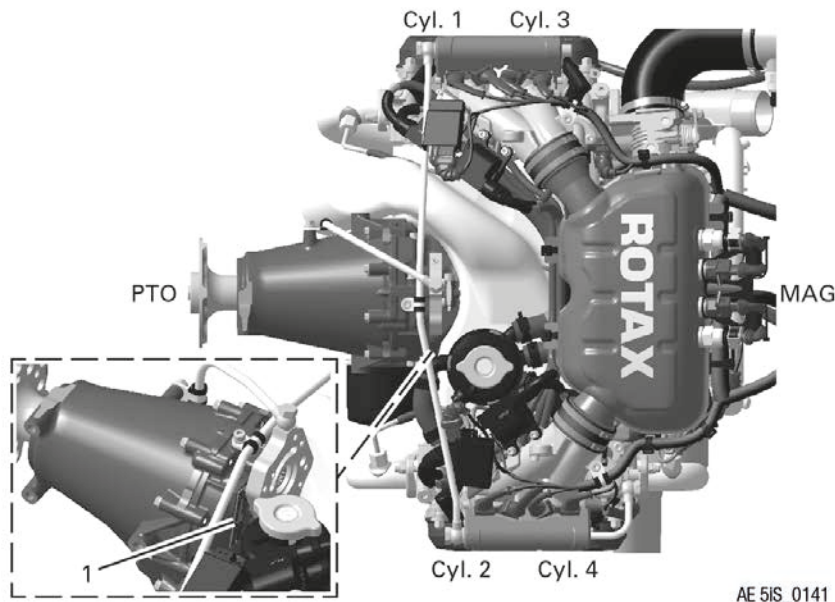



Figure 1.1: Engine serial number

1 Engine serial number

BRP-Rotax
MAINTENANCE MANUAL LINE

ABBREVIATIONS AND TERMS (DEPENDING ON RESPECTIVE ENGINE TYPE)

Abbreviations	Description
*	Reference to another section
	center of gravity
	The drop symbol indicates use of sealing agents, adhesives or lubricants (only in the Maintenance Manual Heavy)
°C	Degrees Celsius (Centigrade)
°F	Degrees Fahrenheit
rpm	Revolutions per minute
A	Ampere
AAPTS	Ambient Air Pressure Temperature Sensor
AC	alternating current
AD	Airworthiness Directives
Ah	Ampere hour
A/C	Aircraft
AC-DC	EMS Modul voltage converter
AR	as required
assy.	assembly
ASB	Alert Service Bulletin
ACG	Austro Control GmbH
ACL	Anti Collision Light
API	American Petrol Institute
ASTM	American Society for Testing and Materials
ATA	Air Transport Association
AWG	American Wire Gauge
CAN	Controller Area Network
CCS	Camshaft position sensor
Coil 1–4	Ignition coils 1–4
CPS 1+2	Crankshaft Position Sensor 1+2
CSA	Constant Speed Actuator
CTS	Cooling Temperature Sensor

BRP-Rotax
MAINTENANCE MANUAL LINE

Abbreviations	Description
CW	clockwise
CCW	counter-clockwise
CGSB	Canadian General Standards Board
DCDI	Dual Capacitor Discharge Ignition
DC	direct current
DOA	Design Organisation Approval
DOT	Department of Transport
EASA	European Aviation Safety Agency
IM	Installation Manual
ECU	Engine Control Unit
EGT	Exhaust Gas Temperature
INTRO	Introduction
EMS	Engine Management System
EMS GND	Engine system internal ground reference which is intended to be disconnected from aircraft common ground during flight
EMC	Electromagnetic compatibility
EN	European Standard
ETFE	Ethylene Tetrafluoroethylene
FAA	Federal Aviation Administration
FAR	Federal Aviation Regulations
FOD	Foreign object damage
FL	Flight Level
Fuse box	Power conditioning and distribution for the Engine Management System
hr.	hours
HIC A	Harness Interface Connector A
HIC B	Harness Interface Connector B
IAT	Indicated Air Temperature
ICA	Instructions for Continued Airworthiness
IFR	Instrument Flight Rules
IFSD	In-flight-shutdown
INJ 1–8	Injector 1–8

BRP-Rotax
MAINTENANCE MANUAL LINE

Abbreviations	Description
IPC	Illustrated Parts Catalog
ips	inch per second
iRMT	independent ROTAX Maintenance Technician
ISA	International Standard Atmosphere
kg	Kilograms
KNOCK	Knock sensor
Lane A	System A of Engine Management System
Lane B	System B of Engine Management System
LOPC	Loss of power control
MAPS 1 & 2	Manifold Air Pressure Sensor 1 & 2
MATS 1 & 2	Manifold Air Temperature Sensor 1 & 2
MCON 1.2	Sealed electrical connector
MON	Motor Octane Number
MAG	Magneto Side
N	Newton
n.a.	not available
NDT	Non Destructive Testing
NEW	Part must be replaced against NEW (mentioned in figures)
Nm	Newtonmeter
NVFR	Night Visual Flight Rules
OAT	Outside Air Temperature
OHM	Overhaul Manual
OHV	Over Head Valve
OM	Operators Manual
OPS	Oil Pressure Sensor
OTS	Oil Temperature Sensor
PCD	Pitch Circle Diameters
PCV	Pressure Control Valve
PMA	Permanent magnet alternator
POA	Production Organization Approval
PS	Power supply

BRP-Rotax
MAINTENANCE MANUAL LINE

Abbreviations	Description
PTFE	Polytetrafluoroethylene (Teflon)
PTO	Power Take Off
Rev.	Revision
ROTAX®	is a trademark of BRP-Rotax GmbH & Co KG
RON	Research Octane Number
RON 424	ROTAX® Standard 424
s.v.	still valid (only Illustrated Parts Catalog)
S/N	Serial Number
SAE	Society of Automotive Engineers
SEP	Single Engine Piston
SB	Service Bulletin
SI	Service Instruction
SI-PAC	Service Instruction Parts and Accessories
SPST	Single pole single throw
STP	Shielded twisted pair wire
SL	Service Letter
SMD	Surface Mounted Devices
TBO	Time Between Overhaul
TC	Type certificate
part no.	part number
TOA	Table Of Amendments
TOC	Table Of Contents
TPS	Throttle Position Sensor
TSN	Time Since New
TSNP	Time Since New Part
TSO	Time Since Overhaul
V	Volt
VFR	Visual Flight Rules
LEP	List of Effective Pages
MM	Maintenance Manual
MEP	Multi Engine Piston















BRP-Rotax
MAINTENANCE MANUAL LINE

Abbreviations	Description
X3	Connector on Engine Management System wiring harness which serves as an interface for power supply
XXXX	shows the component serial number

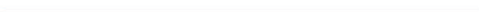
WIRING COLOR CODES

IEC 60757

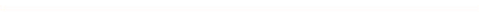
Color codes (wiring)

black		BK
brown		BN
red		RD
orange		OG
yellow		YE
green		GN
blue		BU
violet		VT
gray		GY
white		WH
pink		PK
turquoise		TQ
Light blue		LBU
Dark blue		DBU
gold		GD
silver		SR
green-yellow		GNYE

10336

Figure 1.2

BRP-Rotax
MAINTENANCE MANUAL LINE

CONVERSION TABLE

Units of length:	Units of power:
1 mm = 0.03937 in 1 in = 25.4 mm 1 ft = 12 in = 0.3048 m	1 kW = 1.341 hp 1 hp = 0.7457 kW 1 kW = 1.3596 PS 1 PS = 0.7355 kW
Units of area:	Units of temperature:
1 cm ² = 0.155 sq. in (in ²) 1 sq. in (in ²) = 6.4516 cm ²	0 K = °C – 273,15 °C = (°F – 32) / 1,8 °F = (°C x 1.8) +32
Units of volume:	Units of velocity:
1 cm ³ = 0.06102 cu in (in ³) 1 cu in (in ³) = 16.3871 cm ³ 1 dm ³ = 1 l 1 dm ³ = 0.21997 gal (UK) 1 gal (UK) = 4.5461 dm ³ 1 dm ³ = 0.26417 gal (US) 1 gal (US) = 3.7854 dm ³	1 m/s = 3.6 km/h 1 ft/min = 0.3048 m/min = 0.00508 m/sec 1 m/s = 196.85 ft/min 1 kt = 1.852 km/h 1 km/h = 0.53996 kn
Units of mass:	spec. fuel consumption:
1 kg = 2.2046 lbs. 1 lb. = 0.45359 kg	1 g/kWh = 0.001644 lb/hph 1 lb/hph = 608.277 g/kWh
Density:	Units of torque:
1 g/cm ³ = 0.016018 lb/ft ³ 1 lb/ft ³ = 62.43 g/cm ³	1 Nm = 0.737 ft lb = 8.848 in lb 1 ft lb = 1.356 Nm 1 in lb = 0.113 Nm
Units of force:	Cable cross-section: Conversion table- Wire Gauge: AWG-mm²
1 N = 0.224809 lbf 1 lbf = 4.4482 N	AWG → mm ² 4 → 21 6 → 13 8 → 8.4 10 → 5.3 12 → 3.3 14 → 2.1 16 → 1.3 18 → 0.8 20 → 0.52
Units of pressure:	
1 Pa = 1 N/m ² 1 bar = 100 000 Pa / 1000 hPa / 100 kPa 1 bar = 14.503 lbf/in ² (psi) 1 in Hg = 33.8638 hPa	

BRP-Rotax
MAINTENANCE MANUAL LINE

SAFETY NOTICE

Although reading such information does not eliminate any hazards, it promotes understanding, and applying of the information will promote correct use of the engine. Always apply common workshop safety rules.

The information and descriptions of components and systems contained in this Manual are correct at the time of publication. BRP-Rotax maintains a policy of continuous improvement of its products without imposing upon itself any obligation to retrofit products previously manufactured.

Revisions

BRP-Rotax reserves the right to remove, replace or discontinue any design, specification, feature or other at any time, and without incurring obligation.

Measurement

Specifications are given in the SI metric system with the imperial- and US customary measurement system equivalents in parenthesis.

Symbols used

This Manual uses the following symbols to emphasize particular information. This information is important and must be observed.

⚠ WARNING

Identifies an instruction which, if not followed, may cause serious injury or even fatal injury.

⚠ CAUTION

Identifies an instruction which, if not followed, may cause minor or moderate injury.

NOTICE

Identifies an instruction which, if not followed, may severely damage the engine or could void any warranty.

NOTE

Indicates supplementary information which may be needed to fully complete or understand an instruction.

ENVIRONMENTAL NOTE

Environmental notes give you tips on environmental protection.

A revision bar outside the page margin indicates a change to text or graphic.

BRP-Rotax
MAINTENANCE MANUAL LINE

SAFETY INFORMATION

**Use for intended
purpose**

⚠ WARNING

Non-compliance can result in serious injuries or death!

The user has to assume all risks possibly arising from utilizing auxiliary equipment.

⚠ WARNING

Non-compliance can result in serious injuries or death!

Never fly the aircraft equipped with this engine at locations, air speeds, altitudes or in other situations which do not allow a successful no-power landing after sudden engine stoppage.

- This engine is not suitable for aerobatics (inverted flight, etc.). Flight attitudes outside the permissible limits are not allowed
- This engine has exclusively been developed and tested for fixed wing, gyrocopter, pusher and tractor applications. In case of any other usage, the OEM is responsible for testing and the correct function of the engine
- It should be clearly understood that the choice, selection and use of this particular engine on any aircraft is at the sole discretion and responsibility of the aircraft manufacturer, assembler or owner/user
- Due to the varying designs, equipment and types of aircraft, BRP-Rotax grants no warranty on the suitability of its engines use on any particular aircraft. Further, BRP-Rotax grants no warranty on this engines suitability with any other part, component or system which may be selected by the aircraft manufacturer, assembler or user for aircraft application

⚠ WARNING

Non-compliance can result in serious injuries or death!

For each use of DAY VFR, NIGHT VFR or IFR in an aircraft the applicable legal requirements and other existing regulations must be adhered to.

- In addition to observing the instructions in our Manual, general safety and accident precautions, legal regulations and regulations of any aeronautical authority must be observed
- Where differences exist between this Manual and regulations provided by any authority, the more stringent regulation shall be applied
- For continued airworthiness see Maintenance Manual Line (MML)
- Unauthorized modifications of engine or aircraft will automatically exclude any liability of the engine manufacturer for consequential damage

BRP-Rotax

MAINTENANCE MANUAL LINE

- Engine operation**
- The engine must always be operated according to the content of the latest Operators Manual (OM)
 - To eliminate the risk of injury or damage, ensure any loose equipment or tools are properly secured before starting the engine
 - The use of propellers and their fastenings which exceed the specified values of moment of inertia and imbalance is not allowed and releases the engine manufacturer from any liability
 - Improper engine installation, use of unsuitable piping for fuel, cooling and lubrication system and use of unsuitable wiring for electric and engine management system releases the engine manufacturer from any liability

BRP-Rotax MAINTENANCE MANUAL LINE

INSTRUCTION

Engines require instructions regarding their installation, application, use, operation, maintenance and repair.

Technical documentation and regulations are useful and necessary complementary elements for trainings, but can by no means substitute for theoretical and practical instructions.

These instructions should cover explanation of the technical context, advice for operation, maintenance, installation, use and operational safety of the engine.

Safety notice

In this technical Manual passages concerning safety are especially marked. Pass on safety warnings to other users!

Accessories

This engine must only be operated with accessories supplied, recommended and released by BRP-Rotax. Modifications are only allowed after consent of the engine manufacturer.

Spare parts



See current Illustrated Parts Catalog (IPC) of the respective engine type.

NOTICE

Only use GENUINE ROTAX® spare parts. Spare parts must meet the requirements defined by the engine manufacturer. This can only be guaranteed when using spare parts and/or accessories. Spare parts are available at Authorized Distributors and their independent Service Centers. Any warranty by will become void if spare parts and/ or accessories other than spare parts and/or accessories are used (see latest Warranty Conditions).

See relevant Service Letter on www.flyrotax.com.

Standard tools / Special tools

NOTICE

Only use tools and appliances which are suitable for the relevant task according to the latest Manuals.

State of delivery

⚠ WARNING

Engine and gearbox are delivered in “dry“ conditions (without fuel, oil and coolant).

Before putting the engine into operation it must be filled with oil and cooling liquid. Use only oil and coolant as specified.



See current Operators Manual (OM) and Service Instruction SI-915 i-001 “Selection of suitable operating fluids“ of the respective engine type.

BRP-Rotax MAINTENANCE MANUAL LINE

MAINTENANCE CONCEPT

General note

The maintenance functions detailed in this Manual are divided into two categories:

- Maintenance I (Line Maintenance)
- Maintenance II (Heavy Maintenance)

Repairs beyond the levels detailed in Manual I and Maintenance Manual II are not recommended as maintenance functions and must be in accordance to the current Overhaul Manual (OHM) for the respective engine type. Overhaul Manual (OHM) and its appendix is available for any appropriately rated person or entity on request and by following the standards of the original manufacturer.

Maintenance I (Line Maintenance)

Chapter 00,05 and 12

The scope of line maintenance consists of servicing and adjustment of engine components (including part wear). All procedures in this Manual are to be considered line maintenance.

NOTE

Where applicable, you will be referred to the Maintenance Manual Heavy (MMH) for work above and beyond line maintenance.

Maintenance II (Heavy Maintenance)

Separate Manual.

Maintenance Manual II details removal, installation and repair of components or parts normally considered beyond the scope of "Line Maintenance".

NOTE

This Manual can only be used in combination with Maintenance Manual I (Line Maintenance), as it builds upon it.

BRP-Rotax MAINTENANCE MANUAL LINE

TECHNICAL DOCUMENTATION

These documents form the instructions ensuring continued airworthiness of ROTAX® aircraft engines.

The information contained herein is based on data and experience that are considered applicable for authorized mechanics (iRMT, see MML, Chapter 05–00–00 section “Authorized Personnel”) under normal conditions for engine removal and installation. Concerning design of engine installation in depth knowledge of aircraft design is required.

Due to the fast technical progress and fulfillment of particular specifications of the customers it may occur that existing laws, safety prescriptions, constructional and operational regulations may not be sufficient or cannot be transferred completely to the object bought, in particular for special constructions.

Documentation

- Installation Manual (IM)
- Operators Manual (OM)
- Maintenance Manual Line (MML)
- Maintenance Manual Heavy (MMH)
- Overhaul Manual (OHM)
- Illustrated Parts Catalog (IPC)
- Alert Service Bulletin (ASB)
- Service Bulletin (SB)
- Service Instruction / Service Instruction-Parts and Accessories (SI-PAC)
- Service Letter (SL)



Status

The status of the Manuals can be determined by checking the table of amendments. The first column of this table indicates the revision status, which should be compared with the revision provided on the ROTAX®-Website: www.FLYROTAX.com. Amendments and current versions can be downloaded free of charge.

Replacement pages

Furthermore the Manual is constructed in such a way that single pages can be replaced instead of the complete document. The list of affected pages is given in the chapter LEP. The particular edition and revision number is given on the footer of each page.

Reference

This Manual is only part of the technical documentation and will be supplemented by the respective Operators Manual (OM), Maintenance Manuals and Illustrated Parts Catalog (IPC).

NOTICE

Pay attention to references to other documentation, found in various parts of this Manual.

If not stated otherwise, any reference to a document refers to the latest edition issued by BRP-Rotax.

BRP-Rotax

MAINTENANCE MANUAL LINE



This symbol informs you of additional references (data sheets, Manuals, etc.) associated with the given subject.

Illustrations

The illustrations in this Manual are merely sketches and show typical arrangements. They may not represent full detail or the exact shape of the parts but should outline the same or similar function. Therefore deriving dimensions or other details from illustrations is not permitted.

TYPICAL indicates a general view which may not represent exact details.

NOTE

The Illustrations in this Manual are stored in a graphic database system and are provided with a consecutive, irrelevant, number.

This number (e.g. AE 5iS001) is of no significance for the content.

Some measurements are given in the drawings, these are manufacturing dimensions and are subject to corresponding tolerances.

Installation drawings

Installation drawings and a digital mock-up (DMU) model for (virtual) installation analysis are available from the ROTAX® Authorized Distributors or their independent Service Centers on special request and relevant non disclosure and copyright regulations.

The illustrations in this Manual show a possible installation variant including non certified parts.

BRP-Rotax
MAINTENANCE MANUAL LINE

USE FOR INTENDED PURPOSE

⚠ WARNING
Explosion hazard. Flying components can cause serious injuries. Never run an engine without propeller.

- Use** The ROTAX® 915 iSc A and 915 iSc C24 is/are intended for use in certified aircraft. In case of doubt the regulations of the national authorities or the respective sportive federations have to be observed.
- Certified engines** The certified aircraft engines ROTAX® 915 iSc A and 915 iSc C24 have been tested as per aeronautical standards for safety and time between overhaul. It was developed to conform to the latest technological standards and has been rigorously tested.
- Non certified engines** The ROTAX® 915 iS A and 915 iS C24 are not type certified. These engines have not received any aeronautical standards or regulatory safety or durability testing, and do not conform to any aircraft standards. These engines are meant for use in experimental, uncertificated aircraft and vehicles only in which an engine failure will not compromise safety.

NOTE

These engines are technically equivalent to certified engines and have been manufactured by BRP-Rotax using the same quality assurance system.

- Engine stoppage** In using the engine the operator assumes all risk of use and acknowledges that he/she knows this engine is subject to sudden stoppage.
- Maintenance and repair conditions** Use for intended purpose also includes observation of the operational, maintenance and repair conditions prescribed by the manufacturer. This is a crucial factor concerning the reliability of the engine and can increase the durability of the engine.

BRP-Rotax
MAINTENANCE MANUAL LINE

INTENTIONALLY LEFT
BLANK

BRP-Rotax
MAINTENANCE MANUAL LINE

Chapter: 04-00-00
AIRWORTHINESS LIMITATIONS

TOPICS IN THIS CHAPTER

Approval							
THE AIRWORTHINESS LIMITATIONS SECTION IS APPROVED BY THE EUROPEAN UNION AVIATION SAFETY AGENCY (EASA) IN ACCORDANCE WITH PART 21A.31 (a)(3) AND FAR 33.4. ANY CHANGE TO MANDATORY REPLACEMENT TIME, INSPECTION INTERVAL, AND RELATED PROCEDURES CONTAINED IN THIS AIRWORTHINESS LIMITATIONS SECTION MUST ALSO BE APPROVED.							
rev. no.	chapter	page	date of change	remark for approval	date of approval from authorities	date of issue	signature
1	04-00-00	all	May 01 2025	EASA approved			

Introduction

This chapter 04-00-00 provides information about “Airworthiness Limitations“.

Airworthiness Limitations

— NONE

For the ROTAX® engine type 915 i A/C24 Series the airworthiness limitations are not applicable.

NOTE

*Regarding engine operating limitations see the relevant chapter “Limits of Operation“ in the relevant Operators Manual (OM).
 Maintenance checks and replacement of defined components are required on this engine! These procedures are described in chapter 05 and are required by the authorities in order to ensure Continued Airworthiness!
 See [Chapter 05-00-00 Maintenance](#).*

Continued Airworthiness

Scheduled inspections of the engine including replacement and overhaul of defined components are required in order to ensure Continued Airworthiness of ROTAX® aircraft engines.

BRP-Rotax
MAINTENANCE MANUAL LINE

INTENTIONALLY LEFT
BLANK

BRP-Rotax
MAINTENANCE MANUAL LINE

Chapter: 05-00-00
MAINTENANCE

TOPICS IN THIS CHAPTER

General note	2
Authorized personnel	4
Procedure notes	5
Troubleshooting	7
Consumable Materials	8
Acceptable methods, techniques and practice	12

Introduction The information given in the Maintenance Manual is based on data and experience which are considered to be applicable for a skilled aviation mechanic (iRMT) under normal working conditions.

BRP-Rotax
MAINTENANCE MANUAL LINE

GENERAL NOTE

⚠ WARNING

Non-compliance can result in serious injuries or death!

Besides our instructions in the documentation supplied, also respect generally valid safety and accident preventive directives and legal regulations.

Procedures and limits	The procedures and limits in this Manual constitute the manufacturers official recommendation for engine maintenance and operation.
Instruction	The guidelines given in the Maintenance Manual are useful and necessary supplements to training. They, however, cannot substitute competent theoretical and practical personal instruction.
Modifications	Non-authorized modifications as well as the use of components and auxiliary components not corresponding to the installation instructions exclude any liability of the engine manufacturer.
Parts and accessories	We particularly emphasize that parts and accessories not supplied as genuine BRP-Rotax parts are not verified for suitability by BRP-Rotax and thus are not authorized for use. Installation and/or use of such products may possibly change or negatively influence the constructive characteristics of the engine. For damages resulting from use of non-genuine parts and accessories manufacturer refuses any liability.
Special tools	Maintenance of engines and systems requires special knowledge and special tools. Use only the special tools recommended by BRP-Rotax when disassembling and assembling the engine.
Tightening torques	<p>Tighten fasteners to the torque specified in the exploded view(s) and/or in the written procedure.</p> <p>Accepted accuracy for different measuring tools:</p> <p>Torque: +/- 10% :</p>

⚠ WARNING

Non-compliance can result in serious injuries or death!

Exactly observe the tightening torques for screws and nuts. Overtightening or a connection which is too loose could cause serious engine damage.

In order to avoid a poor assembly, tighten screws, bolts, or nuts in accordance with the following procedure:

- Manually screw all screws, bolts and/or nuts
- Apply half the recommended torque value
- Tighten fastener to the recommended torque value

BRP-Rotax
MAINTENANCE MANUAL LINE

NOTICE

Be sure to use the recommended tightening torque for the specified fastener.

NOTE

When possible, always apply torque on the nut.

NOTE

Always torque screws, bolts and/or nuts using a crisscross pattern when multiple fasteners are used to secure a part. Some parts must be torqued according to a specific sequence and torque pattern as detailed in the installation procedure.

NOTICE

If not specified otherwise, the threads are not lubricated when fastened.

Measuring tools

Calliper rule, dial gauge indicator, micrometer, inner micrometer, inner fine measuring device, feeler gauge, spring scale up to 50 kp (500 N) (112.5 lbf).

Accepted accuracy for different measuring tools:

Pressure: +/- 5%

Distances:

- Inside micrometer or similar: +/- 0.01 mm (0.0004 in.)
- Digital caliper or similar: +/- 0.001 mm (0.00004 in.)
- Bow micrometer or similar: +/- 0.002 mm (0.000079 in.)
- Caliper or similar: +/- 0.03 mm (0.0012 in.)

The changes above are accounting for:

- variations/errors of tools (when used in normal operating conditions)
- accuracy of tools and their related tolerance

Calibration

The professional calibration of your torque wrench is an essential prerequisite for ensuring the quality of the tightening torques in the long term. Calibration is also a fundamental part of ISO 9001 certification.

BRP-Rotax
MAINTENANCE MANUAL LINE

AUTHORIZED PERSONNEL

General note

It is a requirement that all appropriately rated persons organizations/entities or individuals possess the required special tooling. Technicians must have type-specific training according to the SL-915 i-015 Information on the globally standardized iRMT training program for ROTAX® aircraft engine and keep a recurrent knowledge status for the level of work they intend to perform. Technicians may require accreditation from their local aviation authority in addition to any BRP-Rotax requirements.

Requisite knowledge

Any task outlined herein may be performed if the appropriately rated persons organizations/entity or individual has met the following conditions:

Requisite knowledge of the task as a result of:
<ul style="list-style-type: none">• Type-specific training (for the applicable ROTAX® aircraft engine) which is approved by the national aviation authorities and/or BRP-Rotax• Type-specific training as per ROTAX® iRMT program, covering the relevant level/rating for the applicable ROTAX® aircraft engine along with adequate practical experience in performing the task
Appropriately rated persons or organizations/entities must:
<ul style="list-style-type: none">• maintain a suitable work environment to prevent contamination or damage to engine parts or modules• use the required tools and fixtures as outlined in the ROTAX® Maintenance Manual• ensure reasonable and prudent maintenance practices are utilized• ensure the requirements of the applicable regulatory authority regarding running a maintenance organization are met

For more detailed information, maintenance organizations and individuals are encouraged to contact BRP-Rotax through its worldwide distribution network for information and guidance on any of the tasks outlined herein.

See [Chapter 00-00-00 section Technical Documentation](#).

BRP-Rotax
MAINTENANCE MANUAL LINE

PROCEDURE NOTES

General note

⚠ WARNING

Non-compliance can result in serious injuries or death!
When carrying out maintenance and service work, respect all safety regulations.

Ignition “OFF”

⚠ WARNING

Non-compliance can result in serious injuries or death!
This precautionary measure serves to avoid any injuries in case of an unintentional start of the engine.

Principally ensure the following at each maintenance event

- Lane Select Switch Lane A “OFF”
- Lane Select Switch Lane B “OFF”
- Master Switch “OFF”
- Battery Backup Switch “OFF”
- Disconnect battery and secure engine against unintentional operation

Ignition “ON”

At maintenance work which requires ignition “ON” and battery connected, take care of the following:

- Secure the propeller against unintentional turning by hand and
- Secure and observe propeller zone

Handling of operating fluids

⚠ WARNING

Risk of burns and scalds. Hot engine parts.
Always allow engine to cool down to ambient temperature before starting work.

At maintenance of cooling, lubricating and fuel system take care without fail that no contamination, metal chips, foreign material and/or dirt enters the system.

BRP-Rotax
MAINTENANCE MANUAL LINE

Disassembly

At disassembly of the engine, mark the components as necessary to avoid any mix-up. Take care of these marks, don't ruin them.

Tool

NOTICE

In order to avoid mechanical damage, always loosen or tighten screws and nuts with specified tools.

Safety wiring

NOTICE

If during disassembling/reassembling the removal of a safety item (e.g. safety wiring, self-locking fastener, etc.) should be necessary, it must always be replaced by a new one.

Cleaning of parts

NOTICE

All metal and synthetic parts should be cleaned with suitable cleaning agents. Before using new and unknown cleaning agents, check their compatibility with the materials they are being used on.

Removed parts

Before re-using disassembled parts, clean, check and refit them as per instructions. Use clean screws and nuts. Always inspect the contact face and thread for damage. If unsure, use new parts.

Self-securing nuts

Once loosened, always replace self-securing nuts.

⚠ WARNING

Non-compliance can result in serious injuries or death!

Exactly observe the tightening torques for screws and nuts. Overtightening or a connection which is too loose could cause serious engine damage.

Sealing rings, O-rings

At reassembly of the engine, replace all sealing rings, gaskets, securing elements, O-rings and oil seals.

Re-assembly

Before re-assembly check components for missing parts. Only use adhesives, lubricants, cleaning agents and solvents indicated in the maintenance instructions. Failure to comply may result in damage.

BRP-Rotax
MAINTENANCE MANUAL LINE

TROUBLESHOOTING

General notes

Possible problems are listed in the Operators Manual (OM). At the same time, a brief description of the necessary remedial action is given.



See Chapter 4 in the Operators Manual (OM) for engine type 915 i A/C24 Series.

BRP-Rotax
MAINTENANCE MANUAL LINE

CONSUMABLE MATERIALS

General note

NOTICE
Use only the specified or technically equivalent materials for all maintenance work.

NOTICE
When handling chemicals, comply with all the customary regulations and specifications of the producer, including the expiry date and instructions of use.



Consider the curing time of the sealing surface compound as stated by the manufacturers instructions.

Consumables

The materials listed have undergone long term testing and are suitable for all operating conditions indicated by the manufacturer.

No.	Part no.	Description, application	Qty.
AC	899796	LOCTITE 577 Yellow medium duty screw locking agent, oil and cool- ant tolerant	50 ml (0.013 gal (US))
AG	897186	Silicon heat compound Application of the heat conduction compound will in- crease heat transfer. The greaselike, temperature-re- sistant silicone compound fills cavities between components and cooling elements (e.g.: spark plug - cylinder head), which otherwise do not contribute to heat conduction	150 g (0.33 lb)
B	897651	LOCTITE 243 Blue medium duty screw locking agent, oil tolerant	10 ml (0.003 gal (US))
C	899788	LOCTITE 648 Green high temperature screw locking agent + retain- ing compound	5 ml (0.001 gal (US))
E	297438	LOCTITE ANTI SEIZE 8151 Long-term lubricant for shaft seals	50 ml (0.013 gal (US))
F	n.a.	LOCTITE 7063 For degreasing and cleaning surfaces	AR
H	897870	INTAKE FILTER OIL	14.8 ml (0.004 gal (US))

BRP-Rotax
MAINTENANCE MANUAL LINE

No.	Part no.	Description, application	Qty.
I	897330	LITHIUM-BASE GREASE Electrical isolating	250 g (0.55 lb)
O	n.a.	Engine oil For easier assembly of components or for first lubrication before first engine start	AR
P	899791	LOCTITE 5910 Flange sealant provides flexibility and adhesion	50 ml (0.013 gal (US))
V	898570	Locking paint	20 ml (0.006 gal (US))
Z	899789	LOCTITE 603 Oil tolerant retaining compound, heavy-duty	10 ml (0.003 gal (US))

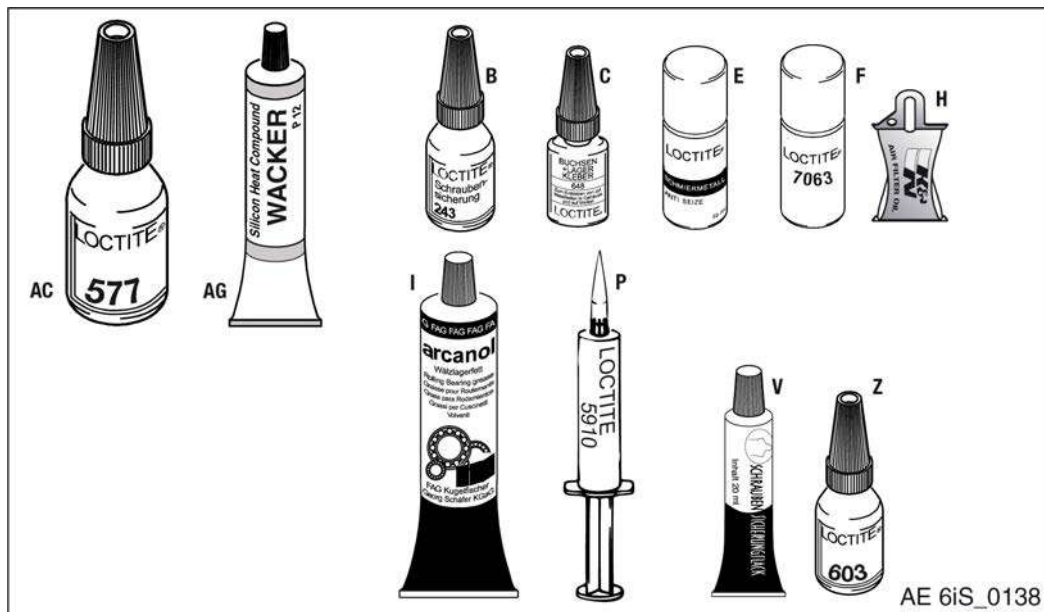

Figure 2.1: Consumables

BRP-Rotax
MAINTENANCE MANUAL LINE

**Additional
materials**

NOTICE

All metal and synthetic parts should be cleaned with suitable cleaning agents. Before using new and unknown cleaning agents, check their compatibility with the materials they are being used on.

No.	Part no.	Description, application	Qty.
1	n.a.	<p>Cleaning agent/solvent/parts cleaner Soak combustion chamber, piston and cylinder head with cleaning agent and remove combustion residues with a bronze brush. Cleaning agents that are solvent - cold cleaner, free of halogen, on the basis of selected fuel fractions and biodegradable are recommended. Never use caustic or corrosive cleaning agents.</p>	AR
2	n.a.	<p>Multipurpose grease Generally usable, neutrally colored multipurpose grease, water resistant and highly adherent. Usable for temperatures from -35 °C to +120 °C (-31 °F to 248 °F) and can be subjected to high mechanical loads.</p>	AR
3	n.a.	<p>Preservation oil This special oil has excellent penetrating capabilities and reaches even tiny gaps, its highly effective additives protect against corrosion of metal surfaces.</p>	AR
4	n.a.	<p>Flexible web for surface finishing 3M Scotch-Brite Multi Flex - very fine or ultra fine (or equivalent) Is sold by the meter and used for manual removal of smaller rust spots or oxidation, especially for optimum ground connections. It is particularly suitable for removing LOCTITE from surfaces or threads to make them metallic clean. Before re-applying LOCTITE, clean surfaces with nitrothinner or degreasing agent (CASTROL ZA 30 or OMV - SOFT SOL). When using solvents, observe the safety regulations for persons and the environment.</p>	AR
5	n.a.	<p>MS4 / DC4 corning #4 (or equivalent) Electrical insulation compound for protection of electrical connections.</p>	AR

BRP-Rotax
MAINTENANCE MANUAL LINE

No.	Part no.	Description, application	Qty.
6	n.a.	<p>Valve lapping paste This paste, produced by various manufacturers, is a fine granulate lapping paste for manual lapping of valve seats and valves. The paste is usually available in 3 different granulate sizes. Use as per manufacturers instructions.</p>	AR
7	n.a.	<p>Compressed air blasting using a solid blasting agent This method is suitable for local and gradual very fine treatment of steel parts with rust film (propeller shaft). The Compressed air blasting contains no harmful substances, is approved by the competent authorities and guarantees optimum cleaning. The granulates used are of sizes 40 to 60 μ. The achievable surface roughness is between 0.5 and 1 μ, which corresponds to ultra fine machining of surfaces.</p>	AR

NOTICE
<p>Exhaust valves and intake valves may NOT undergo a compressed air blasting treatment with solid blasting, strong abrasive material. Due to this surface treatment one does gain a microscopic surface roughness/pitting which does allow as a consequence the adhesion of fuel residues. These deposits are then involved in a chemical reaction (especially of the sulfur and lead content of AV-GAS) with the valve material. This effect may cause hot-gas corrosion on the affected parts.</p>

BRP-Rotax
MAINTENANCE MANUAL LINE

ACCEPTABLE METHODS, TECHNIQUES AND PRACTICE

General note All general inspection, maintenance and repair has to be carried out in accordance with Advisory Circular AC 43.13 from FAA.

Advisory Circular This Manual "Advisory Circular" AC describes maintenance methods, techniques and practice. These are recognized and authorized for inspection and repairs in non-pressurized areas for which there are no separate maintenance and repair instructions.

Corrosion Environmental corrosion (on the external surfaces) is a naturally occurring process which can inevitably affect the continued airworthiness of the engine, engine mounted components and accessories. Susceptibility to corrosion is influenced by a number of factors, including but not limited to, geographical location, season and usage. All general preventive (technical) measures, identification, control and treatment of corrosive attack on aircraft structures and engine materials has to be carried out in accordance with Advisory Circular AC 43-4B from FAA and also in accordance with the information of the aircraft manufacturers Instruction for Continued Airworthiness. Furthermore the preservation procedures for stored and inactive aircraft (engines) provides an effective means for combating and minimizing the corrosion condition and should be adhered to.

Advisory Circular AC 43-4B This advisory circular (AC) is a summary of the current available data regarding identification and treatment of corrosive attack on aircraft structures and engine materials. Corrosion inspection frequency, corrosion identification, and especially corrosion treatment continues to be the responsibility of the operator. These inspections should be accomplished per this AC, the manufacturer's recommendations, or the operator's own maintenance program. The procedures in this AC are an acceptable means, but not the only acceptable means, of corrosion treatment. The information in this AC is applicable to aircraft for which the manufacturer has not published corrosion control information.

Self-locking

NOTICE
Self-locking nuts, cotter pins, tab washers and safety wires must be replaced each time they have been removed.

All instructions regarding the securing and lubrication of parts must be observed Adherence to specified torque values is required.

Nut securing When using a self-locking nut, make sure the polyamide insert ring meets the requirements of DIN 985. Be sure that the securing elements the nut is positioned towards the outside, in accordance with DIN 980.

BRP-Rotax
MAINTENANCE MANUAL LINE

Lock washer

NOTE

When fitting lock washers, the curved-up ends (1) must point towards the screw head or nut.

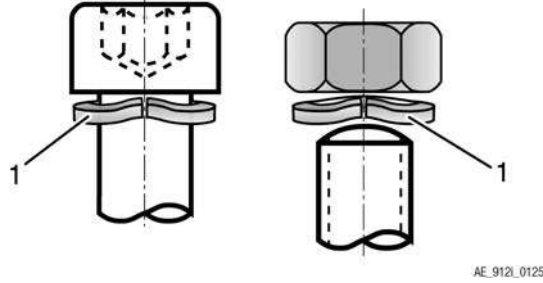

Figure 2.2: Lock washer

BRP-Rotax
MAINTENANCE MANUAL LINE

INTENTIONALLY LEFT
BLANK

BRP-Rotax
MAINTENANCE MANUAL LINE

Chapter: 05-10-00
TIME LIMITS

TOPICS IN THIS CHAPTER

Definition of terms	2
Operating hours	2
Terminology	2
Time limit	3
Life cycle	3
General overhaul (TBO).....	3
Purging the oil system.....	3
Time Limit	4
Time limit for parts	6
Time limit for the coolant	7
Annual inspection	7

Introduction The following checks are required at the times specified. This preventative maintenance is to help avoid and/or detect possible engine issues.

BRP-Rotax
MAINTENANCE MANUAL LINE

DEFINITION OF TERMS

OPERATING HOURS

Definition All of the maintenance intervals, such as the 100 hr. inspection and the engine TBO, relate to the number of operating hours of the engine.

NOTE

Maintenance and overhaul intervals are always dictated by the relevant method used.

NOTE

The planned inspections to be performed at certain intervals are based on experience from long test runs and field observations. They are intended as precautionary maintenance measures in order to ensure continued trouble-free operation of the engine.

General Note

- In aviation there are different measurement methods used as an acceptable means to record operating time elapsed.
- BRP-Rotax does not mandate a specific method to record time elapsed as a basis for maintenance and overhaul intervals.
- BRP-Rotax therefore relies on common practice and defers to the aircraft original equipment manufacturer and/or local regulations.

In order to prevent misunderstandings and to ensure safety, BRP-Rotax accepts any of the following methods to record operating hours:

- mechanical hour meters such as an oil pressure switch, etc.
- electronic hour meters such as BRP-Rotax ECU, TCU, FlyDat, etc.
- "flight Hours" entered in the aircraft's Journey Log or Technical Log.
- operating hours determined by "Hobbs" or "Tach" time (if the aircraft does not have Journey or Technical Log)

TERMINOLOGY

The following terminology is used throughout this Manual, and the meanings are defined as follows:

Inspection

An inspection must be done only by certified mechanics who are approved on this engine, using permitted procedures to make an analysis of the physical condition and find defects. An inspection for condition and possible damage must be done in accordance with the accepted procedures for maintenance (refer to FAA "Advisory Circular" AC 43.13).

Check

A check can be done by pilots and/or mechanics who are approved on this engine and can perform inspections that compare condition with written standards to make sure of condition, precision and tolerances.

Test

A test is the operation of engine components, appliances or systems to make an analysis of performance.

BRP-Rotax

MAINTENANCE MANUAL LINE

TIME LIMIT

Definition Time limits are predetermined time spans and intervals which are based either on calendar intervals or the number of engine operating hours. Once the time limits have been reached, the affected parts must either be replaced for a general overhaul, or maintenance work must be performed. These precautionary maintenance measures are designed to avoid engine malfunctions or defects and ensure continued airworthiness of the engine.

LIFE CYCLE

Definition The life cycle is always specified as an exact time span and is also quoted in flight hours.

NOTE

Parts with a limited life cycle must be taken out of operation and overhauled if the specified time span or number of flight hours is reached (whichever comes first).

GENERAL OVERHAUL (TBO)

Definition The time between overhauls (TBO) for all objects (such as the engine, component assemblies, add-on components) is the approved length of operation under normal operating conditions before it becomes mandatory to send in these objects for an overhaul. Normal operating conditions are the conditions which comply with the manufacturer's and the aviation authority's recommendations for the certification of airworthiness.

Maintenance of operation The TBO values approved by the relevant authorities are based on performance tests and empirical values which have been gathered through operation of the engine and are required for the acceptance and certification of airworthiness. TBO values can be changed in response to possible upgrade/expansion programs.

Legal obligation to keep TBO values for the engine are always shown in operating hours and years. The user must record the operating hours in the engine log book.

PURGING THE OIL SYSTEM

General note Purging of the oil system is extremely important for operation and service life of the engine and therefore the procedure must be followed meticulously.



See current Installation Manual (IM) for the engine type 915 i A/C24 Series, Chapter 79-00-00 Purging the lubrication system.

BRP-Rotax
MAINTENANCE MANUAL LINE

TIME LIMIT

General

NOTICE
A general overhaul is due after a defined period of operation or after a specified calendar life since initial start of operation (whichever comes first).

The time limit for engine operation will be specified by the TBO.

After reaching this time limit

NOTICE
After reaching this time limit, the engine has to be overhauled accordance to the current Overhaul Manual (OHM) for the respective engine type. Overhaul Manual (OHM) and its appendix is available for any appropriately rated person or entity on request and by following the standards of the original manufacturer.

For an overhaul, the engine must be removed from the aircraft, be cleaned, preserved and all openings to be closed to prevent entering of contaminants.

Storage period of the engine

Observe the storage and preservation instructions!

NOTE

The maximum possible storage period of the engine is limited to 24 months.

If this period is exceeded, the engine must be inspected in accordance with the current Maintenance Manual Heavy (MMH) of the respective engine type.

For the TBO of the specific engine type/version refer to the table below.

Engine Type description	Engine affected engine S/N	TBO Time Between Overhaul
915 iSc A	from start of production (EASA certified)	1200 h or 15 years, whichever comes first
915 iSc C24	from start of production (EASA certified)	1200 h or 15 years, whichever comes first
915 iS A	from start of production (ASTM compliant)	1200 h or 15 years, whichever comes first
915 iS C24	from start of production (ASTM compliant)	1200 h or 15 years, whichever comes first

Authorized exceeding

Extension or exceeding of the TBO by 5% or 6 months is allowed, whichever comes first.

BRP-Rotax
MAINTENANCE MANUAL LINE

Shipment

The appropriation for the overhaul must include the following:

1	Engine log book (including date and time of engine removal).
2	Maintenance records of the engine (i.e. all maintenance check lists, and reports of operation, of maintenance, of findings and of oil analyses).
3	The engine assembly as per supply volume. Additionally all added-on parts as in the supply volume such as filters, intake silencer, fuel pump, external alternator, sensors, ignition unit, electric starter, oil tank.
4	Indication of total engine operating hours (TSN) and where applicable, engine operating hours since a previous overhaul (TSO). NOTE <i>This information must be supplied to allow the service history of components to be traced.</i>
5	ECU incl. a statement of the number of times it has been plugged in/ unplugged.
6	FUSE BOX incl. a statement of the number of times it has been plugged in/ unplugged.
7	Harness incl. a statement of the number of times it has been plugged in/ unplugged.
8	Data about the type of aircraft used.
9	Engine position if installed in a multi-engine aircraft.
10	Useful remarks and observations concerning the engine.

BRP-Rotax
MAINTENANCE MANUAL LINE

TIME LIMIT FOR PARTS

General note

NOTICE

This time limit must be followed independently and in addition to the visual inspections (see Chapter 05-20-00 section: Visual Inspection) of the respective components.

Time limit

The following components and systems must be replaced every 5 years:

- All rubber hoses of the cooling system (except GENUINE ROTAX® silicon hoses), which need to be checked by "on-condition" maintenance according to the instructions of continued airworthiness.
- All rubber hoses of the lubrication system which are part of the engine supply volume and if they are not in the maintenance schedule of aircraft manufacturer
- Connecting hose of the air intake system
- V-belt for optional external alternator
- Rubber plate (under expansion tank)
- Fuel pressure regulator assy. (only pressure regulator, not pressure regulator housing)
- Air intake hose (connection between turbocharger and airbox)

BRP-Rotax MAINTENANCE MANUAL LINE

TIME LIMIT FOR THE COOLANT

General note Coolant must be replaced as per manufacturers instructions, at the latest during overhaul or when the engine is replaced.

ANNUAL INSPECTION

General note A 100 hr. inspection is to be carried out after every 100 hours of operation **or every 12 months**, whichever comes first.
See [Chapter 05-20-00 section Scheduled maintenance checks](#).

BRP-Rotax
MAINTENANCE MANUAL LINE

INTENTIONALLY LEFT
BLANK

BRP-Rotax
MAINTENANCE MANUAL LINE

Chapter: 05–20–00
SCHEDULED MAINTENANCE CHECKS

TOPICS IN THIS CHAPTER

Scheduled maintenance checks	2
Unscheduled maintenance checks	3
Visual inspection	4
Maintenance schedule procedures (maintenance check list)	5
Check List/Maintenance Schedule.....	6
Maintenance Schedule	8

Introduction The owner and/or user is primarily responsible for the maintenance and airworthiness of the engine. This includes compliance with all applicable airworthiness directives.

This inspection checklist is not intended to be all-inclusive, for no such checklist can replace the knowledge and experience of a certified aircraft technician. As the party primarily responsible for the maintenance and airworthiness of the engine, the owner or user should only have the maintenance work carried out by qualified technicians (corresponding to the iRMT levels).

Documentation required It is the responsibility of the owner and/or user to make sure that the aircraft technician performing the work on the engine has access to the previous inspection checklist and any other required documents.

BRP-Rotax
MAINTENANCE MANUAL LINE

SCHEDULED MAINTENANCE CHECKS

Definition This section lists the periodic inspections which must be carried out after specified periods of operation.

Intervals Periodic inspections are those which must be performed at 25, 100, 200, 600 hr. intervals in accordance with [Chapter 05-20-00 section Maintenance Schedule](#). This means for example that **every 100 hr** of operation a 100 hr. check must be carried out. Every 200 hr. of operation a 100 hr. and the additional checks for 200 hr. must be carried out.

		Intervals –hours								
		25 hr	100 hr	200 hr	300 hr	400 hr	600 hr	700 hr	to	2000 hr
100 hr		X	X	X	X	X	X	X		X
200 hr				X		X	X			
600 hr							X			

- 100 hr. check or annual check**
- In order to demonstrate continued airworthiness, an engine must be inspected after every 100 hours of operation or 12 months.
 - For the intervals between maintenance work, a tolerance of ± 10 hr. is permissible, but these tolerances must not be exceeded. This means that if a 100 hr. check is actually carried out at 110 hr., the next check will be due at 200 hr. ± 10 hr. and not at 210 hr. ± 10 hr.
 - If maintenance is performed before the prescribed interval, the next maintenance check is to be done at the same interval (e.g. if first 100 hr. check is done after 87 hours of operation, the next 100 hr. check must be carried out after 187 hours of operation).
 - If engine has less than 100 hours of operation during one year a 100 hr. check must be carried out. For the annual inspection a tolerance of ± 2 months is given.

Special hr. check **NOTE**
This maintenance schedule contains a column for a 50 hr. check. This check is recommended by the manufacturer but not essential, with the exception of oil change when operating with leaded AVGAS.

- 25-hr. check**
- In order to demonstrate continued airworthiness, an engine must be inspected after the first 25 hours of operation.
 - The checks performed at the 25 hr. inspection are the same as for the 100 hr. inspection. This applies both to newly delivered engines and to overhauled engines.

BRP-Rotax
MAINTENANCE MANUAL LINE

UNSCHEDULED MAINTENANCE CHECKS

Operating limits exceeded

An inspection of the engine must be performed if the operating limits of the engine have been exceeded (e.g. overspeed, excessive temperature etc.), or if unusual operating conditions have occurred during operation (e.g. lightning strike). In such cases the engine must be inspected in accordance with the applicable unscheduled maintenance checks.

Recommends inspections

The manufacturer also recommends the following inspections whenever maintenance is carried out (where not already prescribed by the airframe manufacturer, as possible malfunctions could have negative effects on engine operation).

part	inspection	possible danger
Exhaust fixation	<ul style="list-style-type: none">• Re-tighten the exhaust fixation on the cylinder head after the first 2 hr. of operation	Leakage
Exhaust	<ul style="list-style-type: none">• Of the exhaust unit (where necessary, replaced application of LOCTITE Anti-Seize)	Risk of fracture, wear. Rough engine running.

BRP-Rotax
MAINTENANCE MANUAL LINE

VISUAL INSPECTION

General note	The scope of a visual inspection generally includes, but is not necessarily limited to, the following:
Moving parts	Normal operating condition, accurate alignment, leak-tightness, cleanliness, ease of movement, adjustment, mechanical stress, travel, catching, extreme wear, cracks, corrosion, deformation and other visually evident damage.
Parts	Secure seating, surface condition, cleanliness, deformation, cracks in welding seams or due to material fatigue or stress, corrosion and other visually evident damage.
Fuel-, Air- and Oil lines and Hoses	Cracks, dents, kinks, required flexibility, collapsed lines/hoses, abrasion, cleanliness, secure seating and other visually evident damage.
Wiring	General cleanliness; loose, corroded or broken terminals; chafed, broken or worn insulation; secure seating, heat damage and other visually evident damage.
Screws and Nuts	Surface damage, secure seating, locking wire, securing paint and other visually evident damage.
Filter and Screens	Filters and screens must be inspected for contamination and potential blockages, cleaned and replaced as required.

BRP-Rotax
MAINTENANCE MANUAL LINE

MAINTENANCE SCHEDULE PROCEDURES
(MAINTENANCE CHECK LIST)

Inspections	All stated checks are visual inspections for damage and wear, unless otherwise stated.
Specified period	All listed work must be carried out within the specified period.
Maintenance check lists	Checks are carried out as per the maintenance check lists, where type and volume of maintenance work is outlined in key words. <ul style="list-style-type: none">• The lists must be photocopied and filled out for each maintenance check.
Extra inspections	<ul style="list-style-type: none">• The respective check (e.g. 100 hr. check) must be noted on the top of each page of the maintenance check list.• All the maintenance work carried out must be initialled in the "signature" area by the aircraft technician performing the task.
Maintenance records	After maintenance, the completed check lists must be entered in the maintenance records. The maintenance must be confirmed in the log book.
Discrepancies/remedial action	All discrepancies and remedial action must be recorded in a report of findings to be generated and maintained by the company authorized to carry out maintenance work. It is the responsibility of the aircraft operator to store and keep the records.
Replacement of equipment	Replacement of equipment (e.g. fuel pump, governor....) and execution of SB (AD) must be entered in the engine log book, stating S/N, TSN and date.

BRP-Rotax
MAINTENANCE MANUAL LINE

CHECK LIST/MAINTENANCE SCHEDULE

Identification	
AIRCRAFT	
Registration number	
Aircraft make	
Aircraft model and S/N	
Time since new	
ENGINE	
Engine type	
Engine S/N	
TSN (time since new)	
TSO (time since overhaul)	
ECU S/N	
FUSE BOX	
Used operating fluids:	
Coolant • mixture ratio	
Fuel	
Oil • type • viscosity	

BRP-Rotax
MAINTENANCE MANUAL LINE

Identification								
AIRCRAFT OPERATOR								
Name								
Contact								
Address								
Telephone/Fax								
E-mail								
MAINTENANCE FACILITY								
Maintenance workshop								
Address								
Telephone/Fax								
E-mail								
Certificate								
This check is applicable (circle on)	25 hr.	50 hr.) 1	100 hr.	200 hr.	400 hr.	600 hr.	1000 hr.	
)1leaded fuel more than 30% of operation								
Next check due at:								hr.
								(TSN_____)(engine hr.)

BRP-Rotax
MAINTENANCE MANUAL LINE

MAINTENANCE SCHEDULE

Perform the following maintenance tasks at the intervals shown in the maintenance check list.
 See [Chapter 05-20-00 section 25 hr. check](#).

Legend: X = do the task
 blank = no task required

NOTE

*If the tasks 1-3 are correct continue with the maintenance schedule.
 If one of the tasks 1-3 is not fulfilled, the engine must be checked and repaired in accordance with the BRP Rotax instructions for continued airworthiness.*

Points of Inspection	Interval Operating hours							Chapter Reference	Signature
	25*	50	100	200	400	600	1000		
* First 25 hours only. (There is no requirement for an inspection every 25 hours)									
1) General note									
All applicable (Alert) Service Bulletins are complied with and documented.	X	X	X	X	X	X	X		
All applicable SI-PAC (Service Instruction Part and Accessories) for additional GENUINE-ROTAX®-parts and accessories used on the relevant aircraft are complied with and documented.	X	X	X	X	X	X	X		

BRP-Rotax
MAINTENANCE MANUAL LINE

Points of Inspection	Interval Operating hours							Chapter Reference	Signature															
	25*	50	100	200	400	600	1000																	
* First 25 hours only. (There is no requirement for an inspection every 25 hours)																								
2) Differential pressure check																								
Check the compression by the differential pressure method. Test pressure _____ hPa (psi) <table border="1" style="width: 100%; margin-top: 5px;"> <thead> <tr> <th colspan="5">Pressure drop (% or fraction)</th> </tr> <tr> <th>Cyl. #</th> <th>1</th> <th>2</th> <th>3</th> <th>4</th> </tr> </thead> <tbody> <tr> <td>bar/psi</td> <td></td> <td></td> <td></td> <td></td> </tr> </tbody> </table>	Pressure drop (% or fraction)					Cyl. #	1	2	3	4	bar/psi						X ⁽²⁾	X ⁽¹⁾	X				12-20-00 Checking the compression	
Pressure drop (% or fraction)																								
Cyl. #	1	2	3	4																				
bar/psi																								
⁽¹⁾ use of leaded fuel (AVGAS) more than 30% of operation. ⁽²⁾ every 50 hours until 400 operating hours, if equipped with part no. 815253 Rectangular Ring 84/77X1.5 (NOT phosphate coated). Engine S/N affected: 915 i Series from S/N 9122005 up to S/N 10004312 inclusive. Please check your Maintenance Logs to verify if the rectangular ring was changed during maintenance / service or overhaul.		X ⁽²⁾	X ⁽¹⁾	X																				
3) Spark plug																								
Check that spark plug connectors fit tightly on the spark plugs. Minimum pull-off force is 30 N (7 lb).				X				12-20-00 Inspection of spark plugs																
Remove all spark plugs and check for spark plug defects (deposits, melting,...), clean and check electrode gap. Check if GENUINE-ROTAX®-spark plugs are used.	X		X					12-20-00 Remove the spark plugs																
Replace spark plugs.				X ⁽¹⁾	X			12-20-00 Installation of spark plug																

BRP-Rotax
MAINTENANCE MANUAL LINE

Points of Inspection	Interval Operating hours							Chapter Reference	Signature
	25*	50	100	200	400	600	1000		
* First 25 hours only. (There is no requirement for an inspection every 25 hours)									
(1 use of leaded fuel more than 30% (AVGAS) of operation)									
4) Inspecting the magnetic plug									
Check the magnetic plug.	X		X					12-20-00 Inspecting the magnetic plug	

BRP-Rotax
MAINTENANCE MANUAL LINE

Points of Inspection	Interval Operating hours							Chapter Reference	Signature
	25*	50	100	200	400	600	1000		
* First 25 hours only. (There is no requirement for an inspection every 25 hours)									
5) Inspecting the oil filter									
Remove oil filter from engine. Cut old filter without producing any metal chips and inspect following components for wear and/or missing material Filter mat: Findings: _____ - _____		X ⁽¹⁾	X					12-20-00 Inspection of the oil filter components	
(1 use of leaded fuel more than 30% of operation.									
6) Visual inspection of the engine									
General visual inspection of the engine for damage or abnormalities. Check cooling air duct and cooling fins of the cylinders for obstruction, cracks, wear and good condition. Take note of changes caused by temperature influence.	X		X					12-20-00 Visual inspection	
Inspect temperature sensors and oil pressure sensor for secure fit and signs of wear.			X						
Inspect all coolant hoses of the engine for damage, including leakage, hardening from heat, porosity, loose connections and secure attachment. Verify routing is free of kinks and restrictions.	X		X					12-20-00 Leakage check	
Carry out visual inspection of leakage bore at the base of the water pump for signs of leakage.	X		X					12-20-00 Leakage check	
Check steel fuel rails for any cracks and/or scuffing marks.	X		X					12-20-00 Checking the fuel lines	

BRP-Rotax
MAINTENANCE MANUAL LINE

Points of Inspection	Interval Operating hours							Chapter Reference	Signature
	25*	50	100	200	400	600	1000		
* First 25 hours only. (There is no requirement for an inspection every 25 hours)									
Inspect the wiring (wiring harness) and its connections for secure fit, damage and signs of wear.	X			X				12-20-00 Check of wiring	
Check the airbox (GENUINE ROTAX® part) incl. throttle body actuation. Inspect sensors for tight fit, damage from heat, damage and signs of wear.	X		X						
Inspection of the GENUINE ROTAX® exhaust system included in the standard delivery. NOTE <i>If there is no GENUINE ROTAX® exhaust system in use, the specifications of the manufacturer must be observed.</i>			X						

BRP-Rotax
MAINTENANCE MANUAL LINE

Points of Inspection	Interval Operating hours							Chapter Reference	Signature
	25*	50	100	200	400	600	1000		
* First 25 hours only. (There is no requirement for an inspection every 25 hours)									
7) Oil change									
Drain oil from oil tank.	X	X ⁽¹⁾	X					12-20-00 Oil change, Flushing the oil circuit	
Check the oil tank and clean the oil tank if contaminated.			X ⁽¹⁾	X				12-20-00 Oil change, Cleaning the oil tank	
Refill oil tank with approx. 3 litres of oil. For oil quality, see Operators Manual latest edition.	X	X ⁽¹⁾	X					12-20-00 Flushing the oil cir- cuit, Purg- ing the oil system	
Inspect and clean screen in turbo oil sump.		X ⁽¹⁾	X					12-20-00 Turbo sump screen	
Install new oil filter	X	X ⁽¹⁾	X					12-20-00 Oil filter change	
(1 use of leaded fuel (AVGAS) more than 30% of operation)									
8) Fuel system									
Inspect the fuel system on the engine side for leaks.			X					12-20-00 Fuel system	
Inspect the fuel system for damages.			X					12-20-00 Fuel system	
Visual inspection of the GENUINE-ROTAX fuel filter			X					see SI-PAC-007	

BRP-Rotax
MAINTENANCE MANUAL LINE

Points of Inspection	Interval Operating hours							Chapter Reference	Signature
	25*	50	100	200	400	600	1000		
* First 25 hours only. (There is no requirement for an inspection every 25 hours)									
Replacement of the GENUINE-RO-TAX fuel filter (periodically at TSN or TSO > 100 hours) NOTE <i>If no GENUINE-ROTAX fuel filter is used, the specifications of the aircraft manufacturer must be observed.</i>			X ⁽³⁾	X				see SI-PAC-007	
(3) Replace the filter after the first 100 hours, then every 200 hours or max. after 2 years (whichever occurs first)									
9) Engine management									
Check the ECU and its mountings.						X		12-20-00 Checking ECU	
In case of faults or warnings read out the ECU fault memory (fault and data logs).	X		X					12-20-00 Read out the ECU data memory	
10) FUSE BOX									
Check the FUSE BOX and its mounting.						X			
Visual inspection of the fuses.	X		X						
11) 28 V AC-DC Converter assy									
EMS and Airframe circuit test for AC-DC Converter (915 iSc C24 only).						X		12-20-00 EMS and Airframe circuit test	

BRP-Rotax
MAINTENANCE MANUAL LINE

Points of Inspection	Interval Operating hours							Chapter Reference	Signature
	25*	50	100	200	400	600	1000		
* First 25 hours only. (There is no requirement for an inspection every 25 hours)									
12) Checking the wastegate lever									
Check the wastegate lever for free running and correct position	X		X					12-20-00 Turbo-charger	
Lubricate the wastegate lever.	X		X					12-20-00 Turbo-charger	
13) Checking the propeller gear box									
Inspect the external surface of the propeller shaft for corrosion. In the case of moderate corrosion, remove the propeller and inspect the propeller shaft flange for corrosion			X					See MMH Chap. 72-10-00	
In the case of excessive corrosion, the propeller shaft should be removed for corrosion inspection and corrosion removal			X					See MMH Chap. 72-10-00	
Coat the exposed surface of the propeller shaft with corrosion inhibitor (do not apply any inhibitor to propeller/flange contact surface)			X					See MMH Chap. 72-10-00	
Check gear set (pittings)						X		See MMH Chap. 72-10-00	
Check wear on tooth of overload clutches						X		See MMH Chap. 72-10-00	
Check overload clutches						X		See MMH Chap. 72-10-00	

BRP-Rotax
MAINTENANCE MANUAL LINE

Points of Inspection	Interval Operating hours							Chapter Reference	Signature
	25*	50	100	200	400	600	1000		
* First 25 hours only. (There is no requirement for an inspection every 25 hours)									
Check wear on the intermediate shaft						X		See MMH Chap. 72-10-00	
Change torsion shaft						X		See MMH Chap. 72-10-00	

Points of Inspection	Interval Operating hours							Chapter Reference	Signature
	25*	50	100	200	400	600	1000		
* First 25 hours only. (There is no requirement for an inspection every 25 hours)									
14) Checking the cooling system									
Inspect the expansion tank for damage and abnormalities. Check coolant level, replenish as necessary. Inspect radiator cap. Inspect protection rubber on expansion tank base for correct fit.	X		X					12-20-00 Expansion tank, radiator cap	
Flushing the cooling system if massive deposits on the expansion tank or radiator cap and/or if the coolant manufacturer required a change interval.	when replacing the coolant							12-20-00 Flushing the cooling system	
15) Engine cleaning									
Engine cleaning.	X		X					12-20-20 Engine cleaning	
16) Liquid level check									
Verify liquid level, replenish as necessary.	X		X					12-10-00 Fluid capacities	
17) Checking the pop-off valve									

BRP-Rotax
MAINTENANCE MANUAL LINE

Points of Inspection	Interval Operating hours							Chapter Reference	Signature
	25*	50	100	200	400	600	1000		
* First 25 hours only. (There is no requirement for an inspection every 25 hours)									
Check the pop-off valve for 700 mbar / 10.15 PSI low-pressure and its full opening.			X					See MMH Chap. 73-10-00	
18) Engine test run									
Observe the safety instructions!									
Start the engine and run to operating temperature. Limits see latest Operators Manual (OM) LANE check at _____ rpm engine speed. Speed drop without LANE: A (Off) _____ rpm B (Off) _____ rpm A/B (difference) _____ rpm	X		X					12-20-00 Test run of engine	

Points of Inspection	Interval Operating hours							Chapter Reference	Signature
	25*	50	100	200	400	600	1000		
* First 25 hours only. (There is no requirement for an inspection every 25 hours)									
19) Crankcase pressure check									
Check the crankcase pressure. Test pressure _____ mbar (psi) (¹ use of leaded fuel (AVGAS) more than 30% of operation			X ⁽¹⁾					See Installation Manual (IM) Chap. 79-00-00	
Returning engine to service On the engine identified as per Check List/Maintenance Schedule , a <u>25 hr</u> ; 50 hr; 100 hr; 200 hr; 400 hr; 600 hr; <u>1000 hr</u> (circle correct maintenance interval) was performed. Check at _____ hr. TSN / TSO (circle applicable engine time) _____ was carried out according to recommendations of the engine manufacturer and was recorded in the Engine Log book. Location, Date _____ Inspector _____ Aircraft mechanic _____ Certificate No. _____									

BRP-Rotax
MAINTENANCE MANUAL LINE

INTENTIONALLY LEFT
BLANK

BRP-Rotax
MAINTENANCE MANUAL LINE

Chapter: 05–50–00
UNSCHEDULED MAINTENANCE CHECKS

TOPICS IN THIS CHAPTER

Engine check after propeller strike incidents	2
Removal of the propeller gearbox	2
Drive gear – Removal	6
Propeller Strike Inspection	7
Installation of propeller gearbox	13
Examination after engine failure	19
Returning engine to service after submerging in water	20
Inspection in extreme climatic conditions	21
Diminished functional capability of EMS	21
Returning engine to service after influence by fire	22
Exceeding of max. admissible engine RPM	22
Exceeding of max. coolant temperature	24
Non compliance with the coolant specification	26
Checking of the Cooling system / radiator cap	27
Exceeding the max. permissible oil temperature	33
Oil pressure below minimum value	34
Oil specification not respected	37
Spark plug not in accordance with specification	39
Non compliance of fuel quality	39
Smooth performance of the engine	40
Sudden drop in boost pressure and speed	42
Sudden increase in boost pressure and speed	43
Periodic rise and fall in boost pressure and speed (oscillation of turbo control unit)	44
Lightning strike	44
Customer Service Information Report (CSIR)	45

Introduction

Special checks must be carried out before next or further flights in the event of an engine fault (e.g. abnormal operation as defined in the Operators Manual (OM) which impairs the airworthiness of the engine.

NOTICE

In the course of special checks specify if additional checks for components (e.g. hydraulic governor) are applicable. After each special check/repair work, an engine test run and a leakage check must be carried out.

NOTICE

Observe without fail all the specified instructions.

ENGINE CHECK AFTER PROPELLER STRIKE INCIDENTS

Definition

A propeller strike is:

- Any incident while the engine is stationary or running which makes it necessary to perform repairs on the propeller.

REMOVAL OF THE PROPELLER GEARBOX

Preparation

Before the propeller gearbox is removed, the work described below must be carried out to identify any further malfunctions in the propeller gearbox and rectify them as part of repair work.

NOTICE

If these checks are omitted, it may be necessary to dismantle the propeller gearbox again to rectify any faults after it has been repaired.

- General visual inspection. See Chapter 12–20–00
- Engine cleaning. See Chapter 12–20–00
- Remove surrounding assemblies.
- Remove external alternator if installed.

NOTE

The assemblies and lines are only to be removed if necessary and only as far as is necessary!

BRP-Rotax
MAINTENANCE MANUAL LINE

Step	Procedure
1	Lock the crankshaft into place according to Chapter 12-20-00 section.

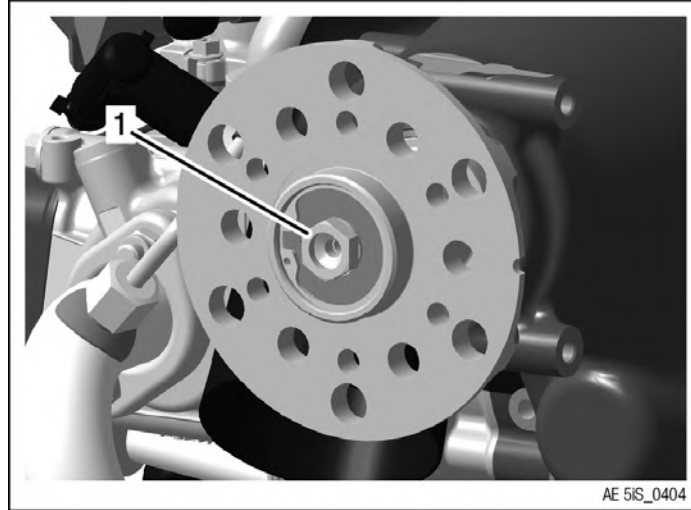

Figure 5.1: TYPICAL

1 Hex. screw

Step	Procedure
2	Loosen M12x20 hex. screw with sealing ring. NOTE <i>Do not remove the hex. screw completely.</i>
3	Loosen two Hex./Torx-flange screws M8x45 and ten Hex./Torx-flange screws M6x40 from the gear cover diagonally from each other. The gear cover is aligned with two dowel pins.

BRP-Rotax
MAINTENANCE MANUAL LINE

NOTICE

When removing the propeller gearbox, take care not to damage the bearing point and the oil seal running surface (on the roller bearing side) of the propeller shaft.

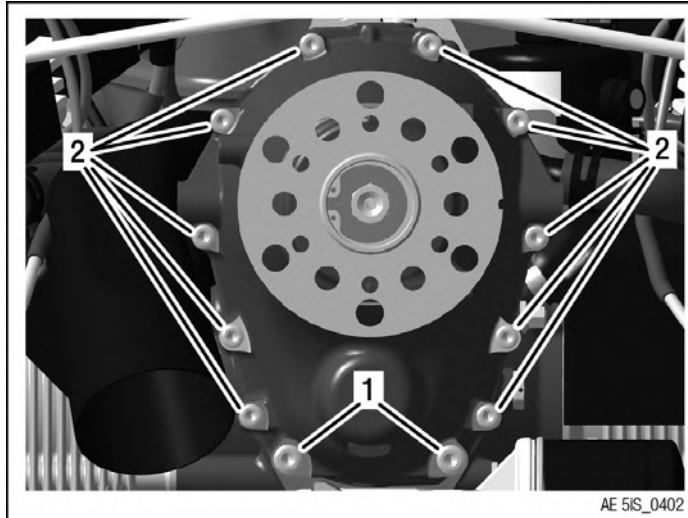

Figure 5.2: TYPICAL

1 Hex./Torx-flange screw M8x45

2 Hex./Torx-flange screw M6x40

Step	Procedure
4	Install puller part no. 877660 onto the two threaded bolts M8 of the gear cover.
5	The entire propeller gearbox can now be pulled off by moving the handle of the special tool part no. 877660 without damaging the ball bearing or propeller shaft.

⚠ WARNING

Non-compliance can result in serious injuries or death!
Overload clutch, torsion shaft and propeller shaft are installed in splines only, they can and will separate from removed gearbox.

BRP-Rotax
MAINTENANCE MANUAL LINE

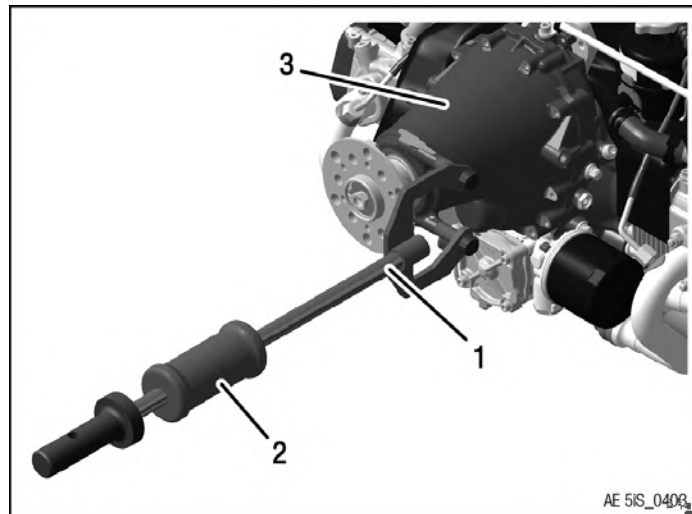

Figure 5.3: TYPICAL

1 Puller part no. 877660

2 Handle

3 Gearbox housing

BRP-Rotax
MAINTENANCE MANUAL LINE

DRIVE GEAR – REMOVAL

NOTICE	
<p>The large and small gears are considered the same part (with the same part number and same serial number). They must not be mixed up with other gear sets.</p>	

Step	Procedure
1	Lock the crankshaft into place. See Chapter 12–20–00.
2	Heat the hex. nut M30x1.5 with the hot air gun (100–120 °C (212–248 °F)).
3	Turn clockwise (left hand threads) to loosen hex. nut M30x1.5 with socket wrench SW 41 part no. 877445.

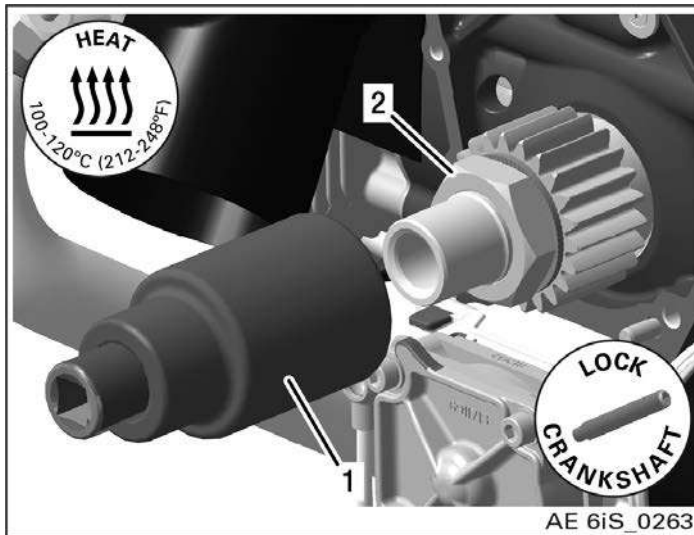

Figure 5.4

- 1 Socket wrench SW 41 part no. 877445 2 Hex. nut M30x1.5

Step	Procedure
4	Remove the drive gear and the friction washer from the crankshaft.

NOTE

If necessary, carefully lever off the drive gear with 2 screwdrivers.

NOTE

The gear set (large and small drive gear) are part of the gearbox assy. and both must be included if sending gearbox out for inspection or overhaul.

BRP-Rotax MAINTENANCE MANUAL LINE

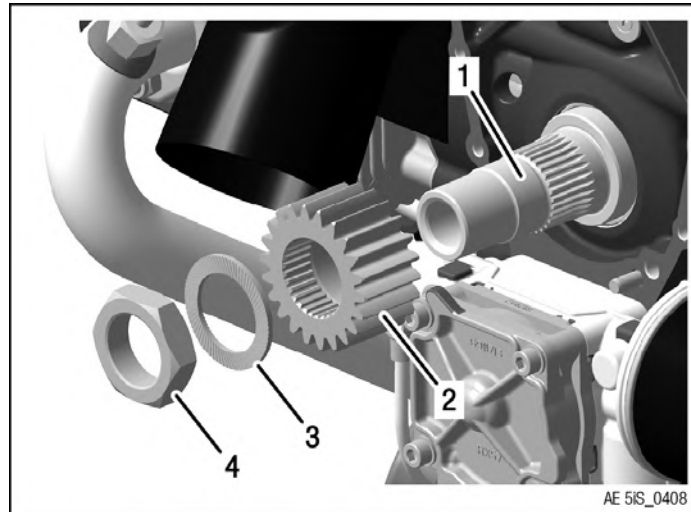

Figure 5.5

- | | |
|-------------------|--------------------|
| 1 Crankshaft | 2 Drive gear |
| 3 Friction washer | 4 Hex. nut M30x1.5 |

PROPELLER STRIKE INSPECTION

General note

NOTICE

Damage to a propeller is serious and can cause the engine to be unairworthy.

After any propeller strike the following inspections must be performed before operation can continue. Some of the following inspections and procedures may require specialized tools and test equipment i.e. clutch disassembly and assembly in accordance with the current Maintenance Manual Heavy (MMH) and need a valid iRMT training.



See current Maintenance Manual Heavy (MMH) for the respective engine type.

BRP-Rotax MAINTENANCE MANUAL LINE

Preparation

NOTE

See current Service Letter SL-915 i-008 "Definition for propeller strike or accidental engine stoppage."

Step	Procedure
1	Remove the surrounding assemblies, see current airframe and propeller manufacturer's instructions.
2	Inspect the engine for damage. If any damage is detected, inspect, repair or overhaul the whole engine in accordance with the relevant Manual. Inspect all systems for correct function. NOTE <i>Particular attention is needed in the corresponding zone of the crankcase and gearbox mounting screw holes, including the dowels.</i>
3	Inspect additional components like e.g. propeller governor, vacuum pump, external generator. Observe the manufacturer's instruction(s).

Procedure



Observe all relevant directives from the aircraft manufacturer.

Step	Procedure
1	Remove the gearbox assy. according to Chapter 05-50-00 section "Removal of the propeller gearbox".
2	Perform a crankshaft run-out inspection on the PTO side. See current Maintenance Manual Heavy (MMH), Chapter 72-10-00.
3	Perform a crankshaft distortion inspection. See current Maintenance Manual Heavy (MMH), Chapter 72-00-00, continue as following: — Remove the drive gear from the crankshaft. See Chapter 05-50-00 section "Removal of the drive gear".

NOTE

Next steps need a valid iRMT training level for all tasks required by the Maintenance Manual Heavy (MMH).

BRP-Rotax
MAINTENANCE MANUAL LINE

Step	Procedure
4	Inspect , repair or perform service of the whole gearbox in accordance with Chapter 72-10-00 of the latest Maintenance Manual Heavy (MMH).
5	<p>Perform NDT inspection of the propeller shaft, gear set and gearbox housing.</p> <p>NOTE</p> <p><i>The gearbox housing has an electrophoretic coating (black) that does not require removal in order to perform a crack inspection.</i></p> <p>NOTE</p> <p><i>The gearbox mounting screw holes and dowel holes must be carefully inspected for any cracks or abnormalities.</i></p>

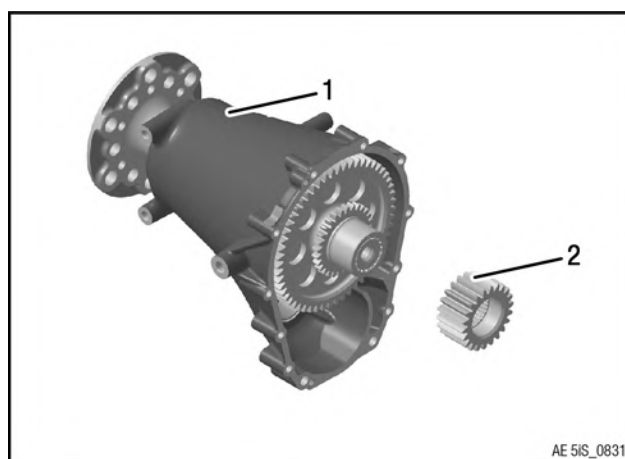

Figure 5.6: Components for inspection

1 Propeller gearbox assy.

2 Drive gear

BRP-Rotax MAINTENANCE MANUAL LINE

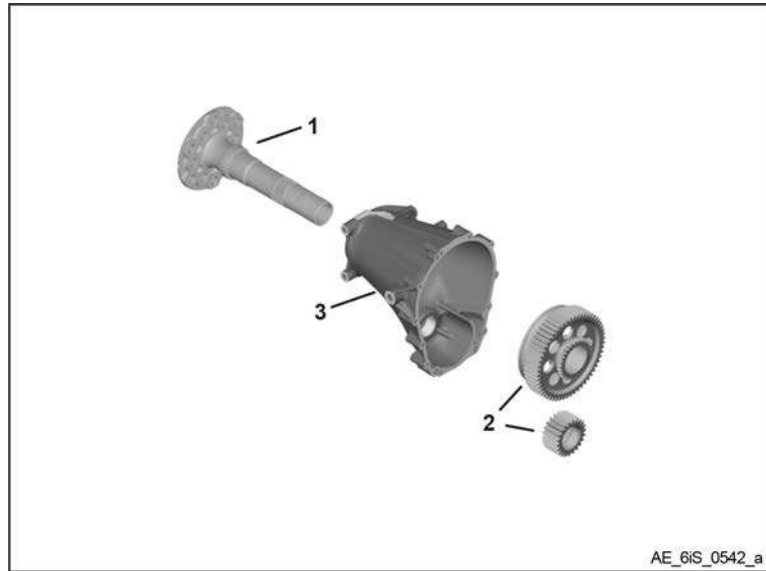

Figure 5.7: NDT inspection

1 Propeller shaft

2 Gear set

3 Gearbox housing

Step	Procedure
6	If cracks are detected, replace the relevant components.



See current Illustrated Parts Catalog (IPC) for the respective engine type.

BRP-Rotax MAINTENANCE MANUAL LINE

100% replacement parts

These parts need to be replaced 100% in course of a propeller strike inspection:

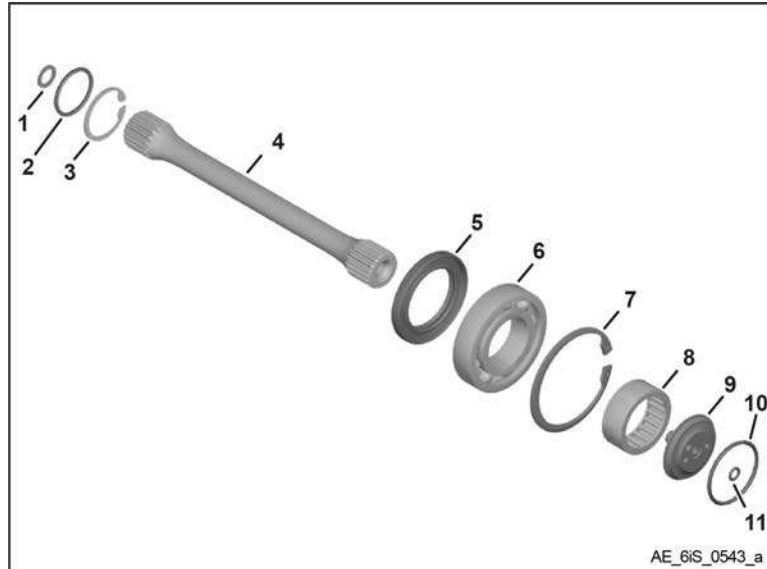

Figure 5.8: 100% replacement parts after propeller strike

- | | |
|--|---|
| <ul style="list-style-type: none"> 1 Sealing ring A12x18 3 O-ring 33x3-N, FPM 75 5 Oil seal AS 48x72x8 7 Retaining ring 80x2.85 9 Oil inlet flange 11 O-ring 7x2 | <ul style="list-style-type: none"> 2 Retaining ring 40x1.75 4 Torsion shaft 6 Ball bearing 6208 TN9 C3 8 Needle bearing 10 O-ring 46x3 |
|--|---|

Step	Procedure
7	Disassemble overload clutch and damper clutch. See current Maintenance Manual Heavy (MMH), Chapter 72-10-00.
8	Check all given wear limits about the gearbox assy. See current Maintenance Manual Heavy (MMH), Chapter 72-10-00, section "Inspection" and "Wear Limits".
9	If a part is not within given limits or has unusual wear or damage, the part needs to be replaced.

BRP-Rotax
MAINTENANCE MANUAL LINE

NOTICE	
All gaskets, O-rings and oil seals must be replaced!	

Step	Procedure
10	Assemble the gearbox. See current Maintenance Manual Heavy (MMH), Chapter 72-10-00, section "Assembly".

Finishing work

NOTE

Next steps need a valid iRMT training level for all tasks required by the Maintenance Manual Line (MML).

Step	Procedure
1	Re-install drive gear in accordance with Chapter 05-50-00 and check the crankshaft for out of roundness. See current Maintenance Manual Heavy (MMH), Chapter 72-10-00.
2	Re-install the gearbox, see Chapter 05-50-00. NOTE <i>- Re-install the gearbox oil line assy, if installed.</i> <i>- Re-install the external alternator, if installed.</i> <i>- Re-install the surrounding assemblies, see current aircraft and propeller manufacturer's instructions.</i>
3	Replenish operating fluids or check filling levels, see Chapter Chapter 12-10-00 Replenishing operating fluids .
4	Purge the oil system, see current Installation Manual (IM) for the respective engine type, Chapter 79-00-00, section Purging the lubrication system.
5	Perform an engine test run in accordance with Chapter 12-20-00, section "Test run of engine". Perform a leakage check of the whole system, see Chapter 12-20-00 section "Leakage check".
6	Release the engine back to service and make an entry in the engine log-book detailing the work carried out.

BRP-Rotax
MAINTENANCE MANUAL LINE

INSTALLATION OF PROPELLER GEARBOX

Preparation

NOTICE

No hammering or pressing!
The drive gear must only be pushed on by hand.

NOTICE

Ensure that the friction washer is in the correct installation position.

NOTICE

The dog and drive gears are in pairs.
Only use parts with the same serial number.

- Clean and degrease all parts carefully.
- Remove LOCTITE adhesive residue with LOCTITE 7063.
- Visual inspection of the crankshaft on the power take off side.
- Lock the crankshaft into place. See Chapter 12-20-00 section

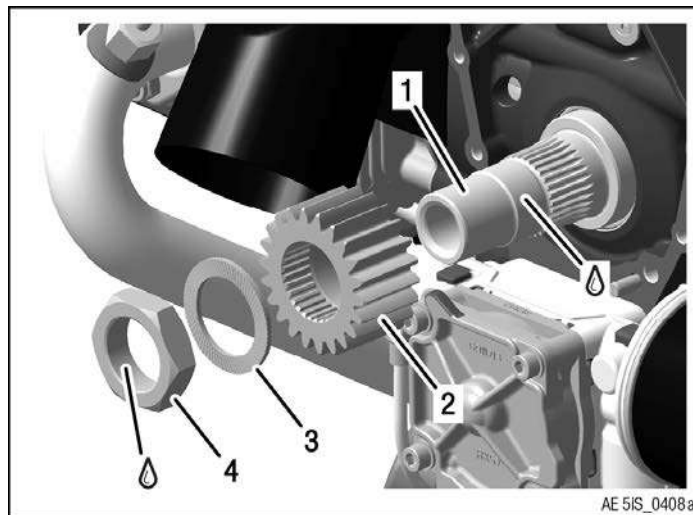

Figure 5.9

- | | |
|---|----------------------------|
| <i>1 Crankshaft (power take off side)</i> | <i>2 Drive gear</i> |
| <i>3 Friction washer VS-30</i> | <i>4 Hex. nut 30 x 1.5</i> |

Step	Procedure
1	Push the drive gear onto the crankshaft.

BRP-Rotax MAINTENANCE MANUAL LINE

NOTE

Due to limited tolerances, it may be difficult to push the drive gear onto the end of the crankshaft. If necessary, push it on in another position.

Step	Procedure
2	Secure the Hex. nut M30x1,5 with LOCTITE 648 and screw it onto the crankshaft along with the friction washer VS-30. Tightening torque 300 Nm (221 ft.lb.).

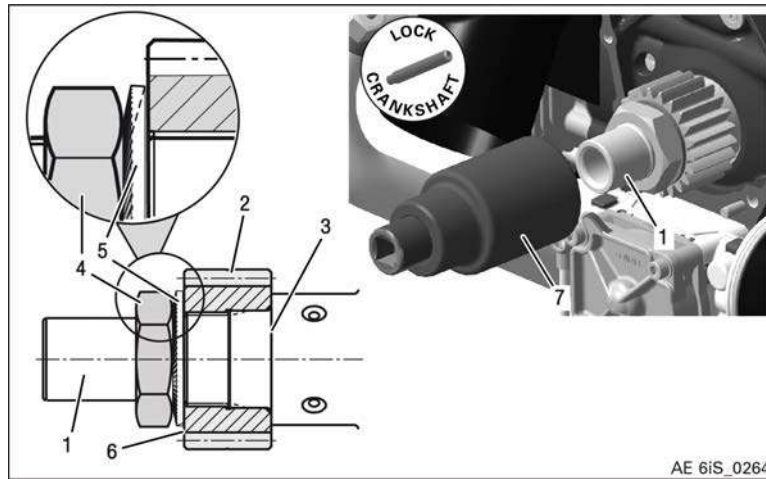

Figure 5.10

- | | |
|---------------------------------------|--------------------|
| 1 Crankshaft (power take off side) | 2 Drive gear |
| 3 Crankshaft | 4 Hex. nut M30x1.5 |
| 5 Friction washer VS-30 | 6 Serial number |
| 7 Socket wrench SW 41 part no. 877445 | |

NOTICE

The sealing surface must be free from dirt and oil.

Step	Procedure
3	Unlock the crankshaft. See Chapter 12-20-00 section
4	Inspect the crankshaft run-out. See also Chapter 72-10-00 section Wear limits. (CS24)

NOTE

If there is a slight vertical run-out, replace the nut and repeat the measurement.

BRP-Rotax
MAINTENANCE MANUAL LINE

Step	Procedure
5	Insert 2 6x20 dowel pins into the crankcase.
6	Apply Engine oil into the needle bearing and lubricate the crankshaft with LOCTITE Anti Seize.

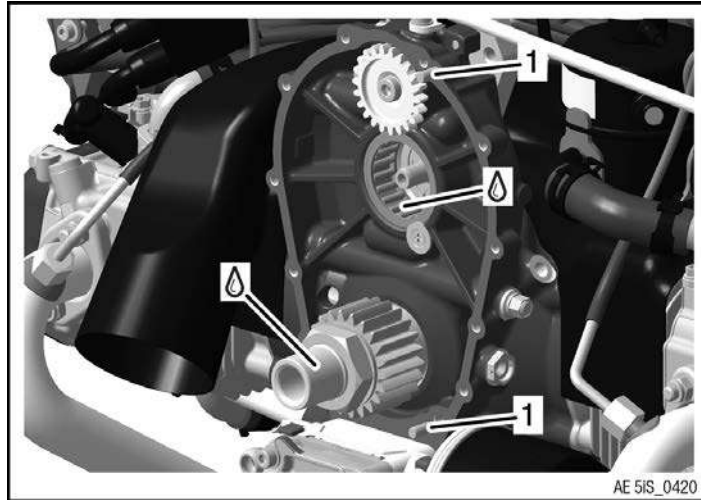

Figure 5.11

1 Dowel pins 6x20

NOTICE

If excessive installation force is used, the bearing or vacuum pump gear can be damaged.

Step	Procedure
7	Check the overload clutch for correctly installation. Observe the mark.

BRP-Rotax
MAINTENANCE MANUAL LINE

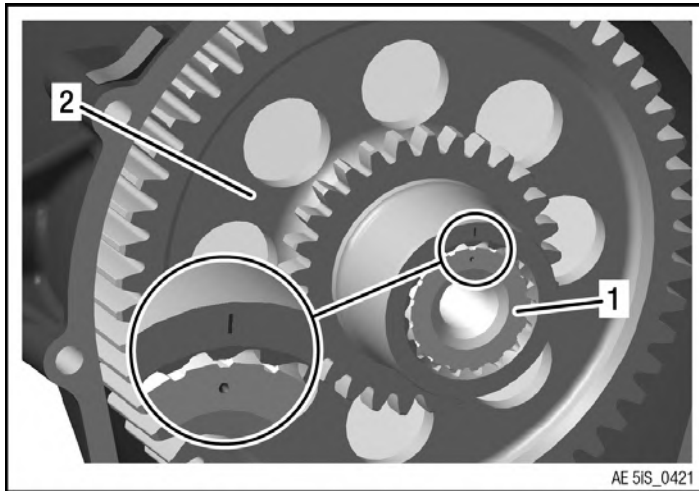

Figure 5.12

1 Torision shaft

2 Overload clutch assy.

NOTE

The outer teeth of the overload clutch align with the sealing surface of the gear housing. If incorrect, the overload clutch will be raised over the sealing. In this case it needs to be investigated, which pairing is mounted wrong and it has to be fixed.

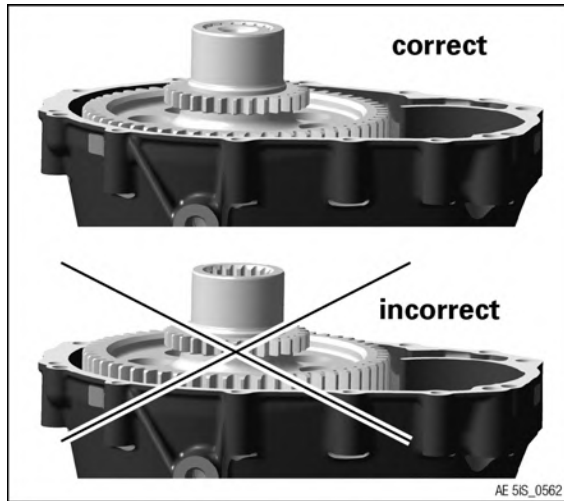

Figure 5.13

Step	Procedure
8	Apply LOCTITE 5910 surface sealing compound to the sealing surface of the gearbox housing and place on the gear cover assy. with the pre-assembled gearbox.

BRP-Rotax
MAINTENANCE MANUAL LINE

NOTE

Move the propeller shaft a little to allow the dog gear to engage.

Step	Procedure
9	Tap gently on the gearbox housing with a soft-faced hammer to position the gearbox on the crankcase.
10	Observe screw pos. 7 at tightening sequence: Secure the Hex./Torx-flange screw M6x40 with LOCTITE 243 . Hand-tighten the screw.
11	Tighten two Hex/Torx-flange screw M8x45 and ten Sk/Torx-flange screws M6x40 diagonally from each other. Fasten the screws according to the tightening sequence. Tightening torque M6: 10 Nm (89 in.lb.) Tightening torque M8: 25 Nm (18 ft.lb.)

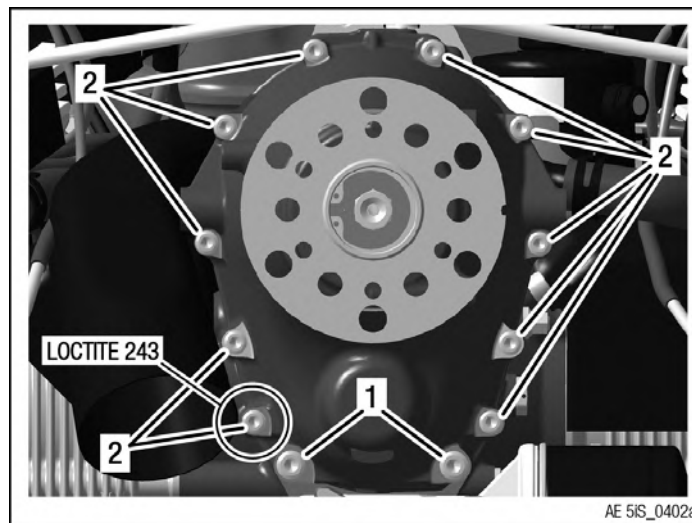

Figure 5.14

1 Hex./Torx-flange screw M8x45

2 Hex./Torx-flange screw M6x40

BRP-Rotax
MAINTENANCE MANUAL LINE

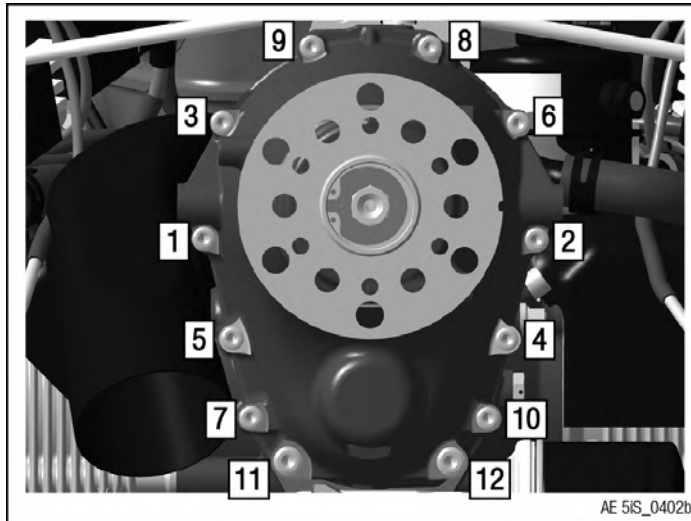

Figure 5.15: Tightening sequence

Step	Procedure
12	Inspect the propeller flange run-out. See also Chapter 72-10-00 section Wear limits. (GB18) .
13	Lock the crankshaft according to Chapter 12-20-00 section " Lock/Loosen of the crankshaft ".
14	Secure Hex. screw M12 x 20 with LOCTITE 243. Tightening torque 20 Nm (15 ft. lb.).

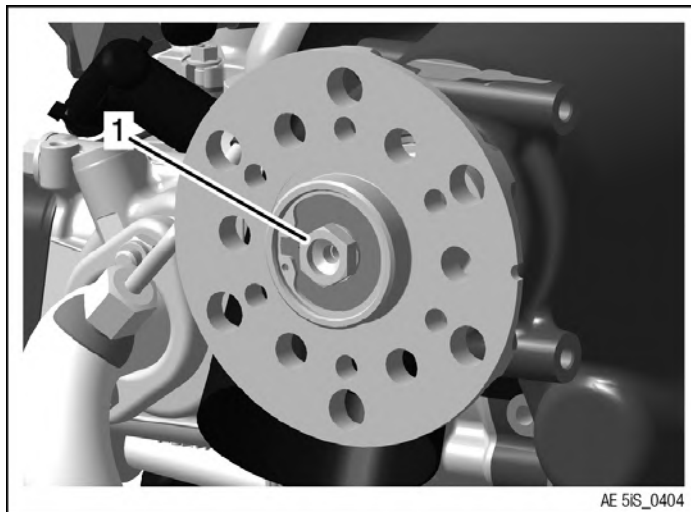

Figure 5.16

1 Hex. screw M12 x 20

BRP-Rotax
MAINTENANCE MANUAL LINE

EXAMINATION AFTER ENGINE FAILURE

General note

In order to find possible causes of the failure, it is important to pass on all available data. Observations on the aircraft and the engine suspension can also be of help. It is important to pay particular attention to any of the following engine phenomena to facilitate troubleshooting.

Engine

Engine runs erratically and misfires	
part	possible cause
Fuel system	fuel supply vapour locks contamination
Ignition system (wiring connectors, charging coil, ignition switch.ECU, FUSE BOX Spark plug, wire and socket	malfunction grounding defect wrong spark plug connection loose connection

Rough running engine

Rough running engine	
part	possible cause
Ignition	wiring (assignment fault)
Engine	engine temperature too low wrong intake air

Engine stoppage

NOTICE
Should one of the above mentioned items occur even for a short time then a detailed check of the engine is necessary. The fault needs to be located and corrected.

Unintended engine stoppage by seizing	
part	possible cause
Oil system	oil pressure too low or no oil pressure oil shortage contamination plugged / restricted venting of oil tank
Oil pump	damaged rotors or drive pin
Camshaft bearings/Conrod bearings	damage and wear (low oil pressure)

NOTICE
The entire assembly must be dismantled, inspected and repaired.

BRP-Rotax MAINTENANCE MANUAL LINE

- The whole engine must be inspected, repaired or overhauled in accordance with the BRP-Rotax instructions for continued airworthiness.
- Inspect all systems for correct functioning.
- Detailed inspection of affected engine components.

Coolant

A rise in coolant temperature above normal operating limits (see Operators Manual) is a clear signal for a failure in the cooling system.

Coolant temperature too high	
part	possible cause
Cooling system	not enough coolant bad venting
Radiator	contaminated sealing of radiator to cowling poor cooling flow
Radiator cap	leaking
Water pump	malfuction

RETURNING ENGINE TO SERVICE AFTER SUBMERGING IN WATER

General note

NOTICE
The engine must be marked clearly “Engine submerged in water“. Define if it was fresh water or salt water.

An engine which has been submerged in water must be inspected, repaired or overhauled in accordance with the BRP-Rotax instructions for continued airworthiness. See current Maintenance Manual of the respective engine type.

Inspection

- Inspect all systems for correct functioning.

NOTE

Prior to the detailed inspection, all parts should be cleaned and inspected for corrosion. For accessories (e.g. vacuum pump, fuel filter etc.) the instructions and specifications of the corresponding manufacturer must be followed.

BRP-Rotax MAINTENANCE MANUAL LINE

Complete inspection of these components:

- power supply
- gearbox
- engine suspension frame
- fuel system
- cylinder unit
- cooling system
- valve train system
- exhaust system
- lubrication system
- start system

In most cases an overhaul is necessary, in this regard the engine has to be overhauled according to the current Overhaul Manual (OHM) for the respective engine type. Overhaul Manual (OHM) and its appendix is available for any appropriately rated person or entity on request and by following the standards of the original manufacturer.

If an engine was submerged into water, all electrical components (e. g.: electric fuel pumps, ignition coils, stators, spark plugs, spark plug connectors, FUSE BOX, sensors, ECU, wiring harness) must be replaced.

NOTE

Discoloration or corrosion are signs of submerging in water.

INSPECTION IN EXTREME CLIMATIC CONDITIONS

General note

NOTICE

Every 25 hr. checks of air filter, coolant radiator and oil cooler are necessary.

Flying in deserts or areas with heavily contaminated or dusty air causes increased wear on all components. For this reason, shorter maintenance intervals are recommended.

Flying in areas with extreme climatic conditions or in extreme altitudes requires adjustment of the cooling system. To do this, it is necessary to contact the aircraft manufacturer and ROTAX® Authorized Distributor or their independent Service Center.

DIMINISHED FUNCTIONAL CAPABILITY OF EMS

General note

NOTE

The diminished functional capability of EMS must be entered by the pilot into the engine log book, stating duration extent of diminished functional capability and all pertinent details.

- Perform engine inspection.

BRP-Rotax MAINTENANCE MANUAL LINE

Read out the ECU data memory and check the data for details of diminished functional capability. Perform the corresponding inspections/repairs depending on the functional defects found.

RETURNING ENGINE TO SERVICE AFTER INFLUENCE BY FIRE

General note An engine after influence by fire must be inspected, repaired or overhauled according to the BRP-Rotax instructions for continued airworthiness.

Inspection • Inspect all systems for correct functioning.

NOTE

Prior to the detailed inspection, all parts should be cleaned and inspected for burn penetration or melted materials.

If an engine was influenced by fire, first a visual inspection of all parts has to be done and then a hardness test of all mechanical parts must be performed (e. g.: crankcase, cylinder, cylinder heads etc.).

In most cases an overhaul is necessary, in this regard the engine has to be overhauled according to the current Overhaul Manual (OHM) for the respective engine type. Overhaul Manual (OHM) and its appendix is available for any appropriately rated person or entity on request and by following the standards of the original manufacturer.

EXCEEDING OF MAX. ADMISSIBLE ENGINE RPM

General note

NOTICE

Any exceeding of the max. admissible engine RPM must be entered by the pilot into the engine log book stating duration extent of overspeeding and pertinent detail.

5800 rpm up to max. 6200 rpm

If the limit was exceeded for max. 1 minute up to 6200 rpm

Step	Procedure
1	No action is required.

5800 rpm up to max. 6200 rpm

If the limit was exceeded for more than 1 minute up to 6200 rpm.

Step	Procedure
1	Check that the push-rods are straight. See current Maintenance Manual Heavy (MMH), Chapter 72- 00-00.

BRP-Rotax
MAINTENANCE MANUAL LINE

**6200 rpm up
to max. 6500
rpm**

If the limit was exceeded for max. 3 seconds up to 6500 rpm

Step	Procedure
1	No action is required.

**6200 rpm up
to max. 6500
rpm**

If the limit was exceeded for more than 3 seconds and max. 1 minute up to 6500 rpm.

Step	Procedure
1	Check that the push-rods are straight. See current Maintenance Manual Heavy (MMH), Chapter 72- 00-00.

**6200 rpm up to
max. 6500 rpm**

If the limit was exceeded for more than 1 minute up to 6500 rpm.

Step	Procedure
1	The whole engine must be inspected, repaired or overhauled in accordance with the BRP-Rotax instructions for continued airworthiness.
2	Check that the push-rods are straight. See current Maintenance Manual Heavy (MMH), Chapter 72- 00-00.
3	Inspect the crankshaft for out-of-roundness and distortion. See current Maintenance Manual Heavy (MMH), Chapter 72- 00-00.
4	Inspect all systems for correct functioning.
5	Detailed inspection of affected engine components.

BRP-Rotax MAINTENANCE MANUAL LINE

more than
6500 rpm

If the speed of 6500 rpm was exceeded.

Step	Procedure
1	The whole engine must be inspected, repaired or overhauled in accordance with the BRP-Rotax instructions for continued airworthiness.
2	Check cylinder differential pressure. See Chapter 12-20-00, section Differential pressure check.
3	Check that the push-rods are straight. See current Maintenance Manual Heavy (MMH), Chapter 72- 00-00.
4	Check if piston had contact with valve. See current Maintenance Manual Heavy (MMH), Chapter 72- 00-00.
5	Check for out of roundness of valves. See current Maintenance Manual Heavy (MMH), Chapter 72- 00-00.
6	Replace the crankshaft. The crankshaft has to be inspected in according to the current Overhaul Manual (OHM) for the respective engine type. Overhaul Manual (OHM) and its appendix is available for any appropriately rated person or entity on request and by following the standards of the original manufacturer.
7	Inspect all systems for correct functioning.
8	Detailed inspection of affected engine components.

EXCEEDING OF MAX. COOLANT TEMPERATURE

General note

NOTICE

If the maximum coolant temperature is exceeded, other limits are also often exceeded, e.g. oil temperature. Please observe the relevant instructions.

NOTE

Any exceeding of the max. admissible coolant temperature must be entered by the pilot into the engine log book, stating duration, extent of excess temperature and pertinent detail.

BRP-Rotax MAINTENANCE MANUAL LINE

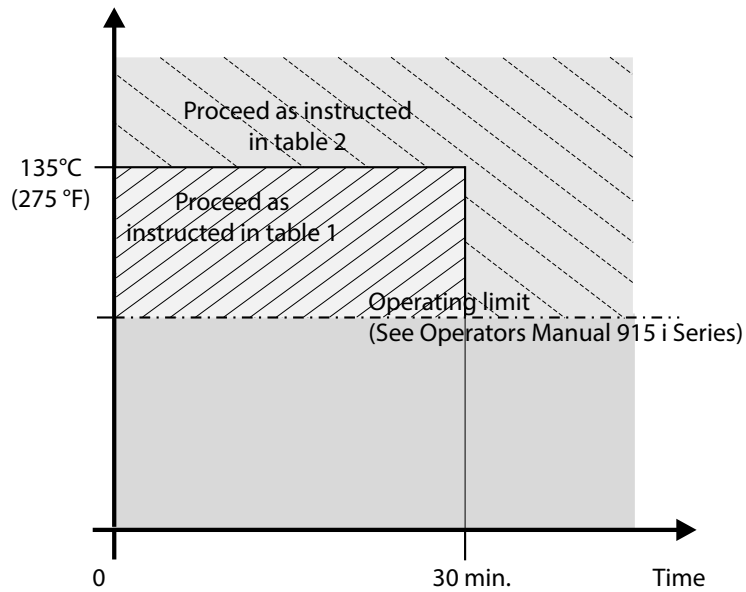

Figure 5.17: Overview and proceed:

Temperature exceeded briefly

Table 1: Exceeded less than 30 min. up to max. 135 °C (275 °F)	
Step	Procedure
1	The whole cooling system must be inspected, repaired or overhauled in accordance with the BRP-Rotax instructions for continued airworthiness.
2	Inspect all further systems for correct functioning.
3	Carry out detailed inspection of the affected engine components such as: <ul style="list-style-type: none"> • Leakage check on the cooling system. • Check that the cylinder head attachment is fitted securely. If any of the cylinder head nuts are loose, proceed as instructed in table 2 “Exceeded for longer than 30 min. and more than 135 °C (275 °F)“. • Check all coolant fittings (feed/outflow) for secure fit.

BRP-Rotax MAINTENANCE MANUAL LINE

Exceeded for longer than 30 min. and more than 135 °C (275 °F)

Table 2: Exceeded for longer than 30 min. and more than 135 °C (275 °F)	
Step	Procedure
1	The whole cooling system must be inspected, repaired or overhauled in accordance with the BRP-Rotax instructions for continued airworthiness.
2	Inspect all further systems for correct functioning.
3	Carry out detailed inspection of the affected engine components.
4	Check compression by carrying out a differential compression check.
5	All cylinder heads and cylinders must be removed and subjected to a detailed check including hardness testing. See current Maintenance Manual (MMH), Chapter 72-00-00.

NON COMPLIANCE WITH THE COOLANT SPECIFICATION

General note

NOTICE
Use only coolant as recommended in the current Operators Manual (OM) and SI-915 i-001 "Selection of suitable operation fluids", current issue.

Non compliance with the coolant specification	
Step	Procedure
1	When a different coolant than the former one (conventional coolant) used, then the coolant system has to be flushed. See Chapter 12-20-00 section Flushing the cooling system .
2	Fill expansion tank with new coolant (highest point of the coolant system). See Chapter 12-10-00 section Coolant check/replenish .
3	Re-install the radiator cap.
4	NOTE <i>Run engine for a minute and replenish as required.</i>

CHECKING OF THE COOLING SYSTEM / RADIATOR CAP

General Cooling system / radiator cap. check in case of unusual leakage and deposits or exceeding of max. cooling system temperature.

⚠ WARNING

Risk of burns and scalds. Hot engine parts.

Always allow engine to cool down to ambient temperature before starting work.

⚠ WARNING

Risk of Burns!

Never open the radiator cap when the cooling system is hot. For safety's sake, cover cap with a rag and open slowly. Sudden opening of the cap could provoke the escape of boiling coolant and result in scalding.

ENVIRONMENTAL NOTE

Protect the environment.

Do not harm the environment by spilling coolant. Dispose of coolant in an environmentally friendly manner.

Special tool

NOTE

Use suitable manual pump with manometer or pressurized-air hose with suitable pressure reduction valve for testing.



Figure 5.18: Special tool

BRP-Rotax
MAINTENANCE MANUAL LINE

Instruction

NOTE

Perform a visual check of the entire cooling system, check for chafing and coolant residue.

Step	Procedure
1	Remove one coolant hose at the upper outlet elbow on the cylinder head, hold the hose up and drain the hose and expansion tank. NOTE <i>It is important to have a container of adequate size ready to capture the coolant before removing the hose.</i>

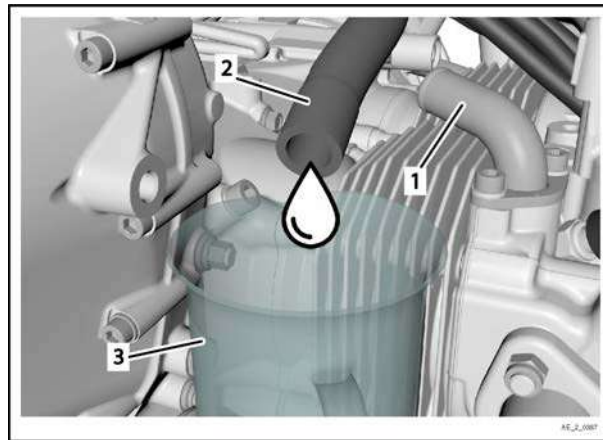

Figure 5.19: TYPICAL

- 1 Coolant outlet elbow
- 2 Upper coolant hose
- 3 Clean container

Step	Procedure
2	Seal the open elbow side with a temporary piece of coolant hose, with a plug inserted in the open end. The plug needs to hold a pressure of 2 bar (29 psi). NOTE <i>Use standard coolant water hose part no. 922250 and self compensating clamp 25 part no. 851645 to secure. Plug diameter 12-13 mm (0.473 in. - .0.512 in.).</i>

BRP-Rotax MAINTENANCE MANUAL LINE

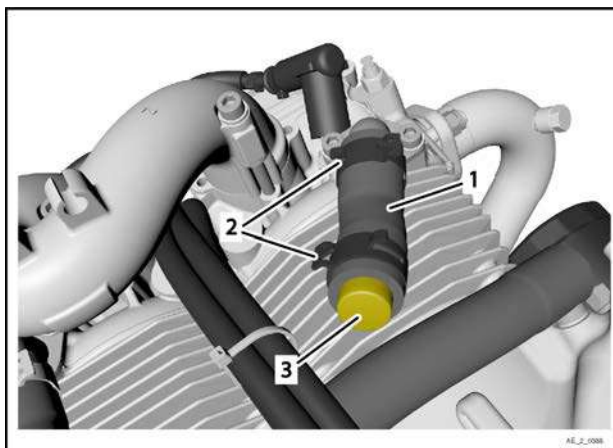

Figure 5.20: TYPICAL

1 water hose part no. 922250

2 Self compensating clamp 25 part no. 851645

3 Plug

Step	Procedure
3	To the open coolant hose, attach an adapter and connect to a manual pump or pressure reduction valve. Use the standard spring clamp to secure the hose on the adapter.

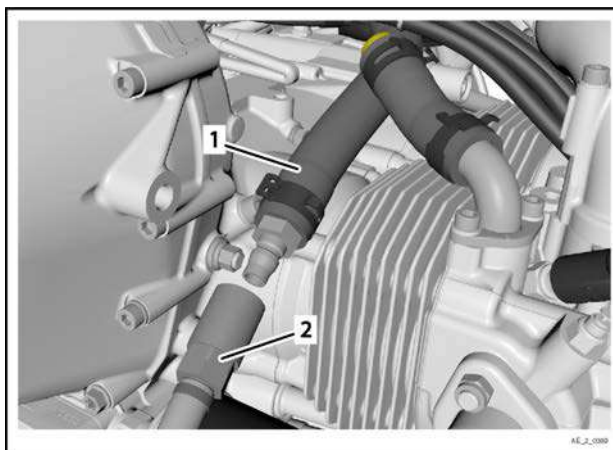

Figure 5.21: TYPICAL

1 Hose to expansion tank

2 To pressure source

BRP-Rotax
MAINTENANCE MANUAL LINE

Step	Procedure
4	Remove the connection hose from expansion tank to overflow bottle and install a temporary clear hose.
5	Refill the cooling system at the expansion tank and overflow bottle to standard levels.
6	Apply small amount of coolant to rubber surfaces inside cap (provides lubrication to prevent binding). Tighten the radiator cap by hand. NOTE <i>The radiator cap must be tightened until the stop lug is contacted</i>

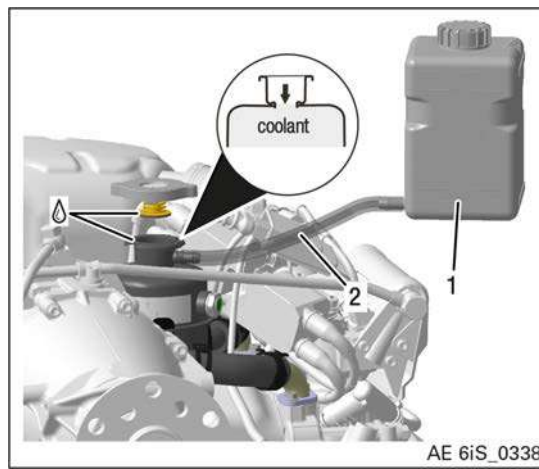

Figure 5.22

1 Overflow bottle

2 Temporary clear hose

Step	Procedure
7	Turn the propeller slowly by hand in the normal direction of rotation several times. Check cooling liquid level again, if necessary replenish.
8	Pressurize the expansion tank up to relief pressure of the cap, indicated by rising bubbles in the clear hose.

NOTICE

Do not relieve pressure via opening the radiator cap. Use pressure relief unit on pump.

BRP-Rotax MAINTENANCE MANUAL LINE

NOTICE

Use only coolant as recommended in the current Operators Manual (OM).

Step	Procedure
9	Check if the relief pressure lies within following limits for both radiator cap types. <ul style="list-style-type: none"> • Min. relief pressure: 1.2 bar (17.4 psi) • Max. relief pressure: 1.6 bar (23.2 psi)
10	If relief pressure is higher than the max. or lower than the min. relief pressure, replace the radiator cap with new and repeat the test.
11	If min. pressure cannot be achieved, or pressure cannot be maintained - check the system to find the leakage.

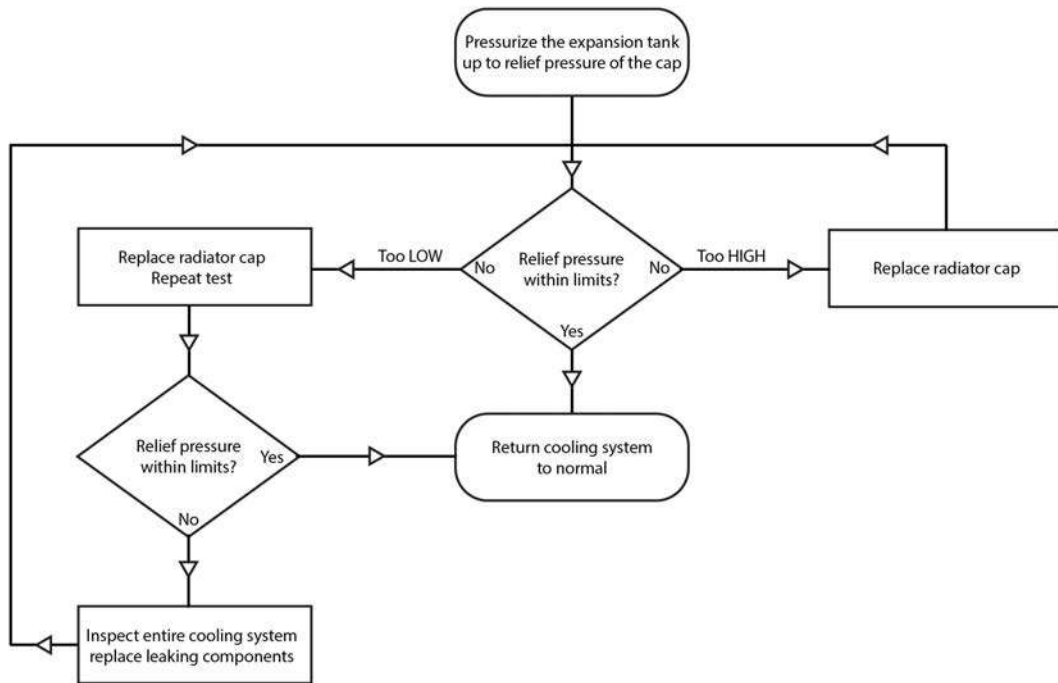

Figure 5.23

⚠ WARNING

Non-compliance can result in serious injuries or death!

For static, on-ground testing of the coolant system. Do not run the engine while configured for pressure testing.

BRP-Rotax
MAINTENANCE MANUAL LINE

NOTE

To make the entire cooling system check easier, the coolant may be entirely drained, and the system pressurized with air only, up to 1.6 bar (23.2 psi.). Check can be performed with leak detection fluid to locate the leakage.

After replacing any part of cooling system perform cooling system check again to make sure the system works correctly.

Return coolant system to normal operating configuration.

Engine test run

Engine test run is necessary:

Step	Procedure
1	Operate the engine until temperatures have stabilized for a period of 5 minute (engine oil temperature between 50 to 70 °C (122 to 160 °F).
2	Switch the engine "OFF".
3	Allow the engine to cool down.
4	Check for leaks.
5	Check the coolant level and top up with coolant as required.

BRP-Rotax
MAINTENANCE MANUAL LINE

EXCEEDING THE MAX. PERMISSIBLE OIL TEMPERATURE

General note

NOTICE

If the max. permissible oil temperature is exceeded, other limits are often exceeded, too, e.g. the cylinder head temperature and coolant temperature. Please observe the relevant instructions.

NOTE

Any exceeding of the max. admissible oil temperature must be entered by the pilot into the engine log book, stating duration and extent of excessive temperature and pertinent detail.

Read out the ECU data memory and check the data for details of increased oil temperature. Perform the corresponding inspections/repairs depending on the functional defects found.

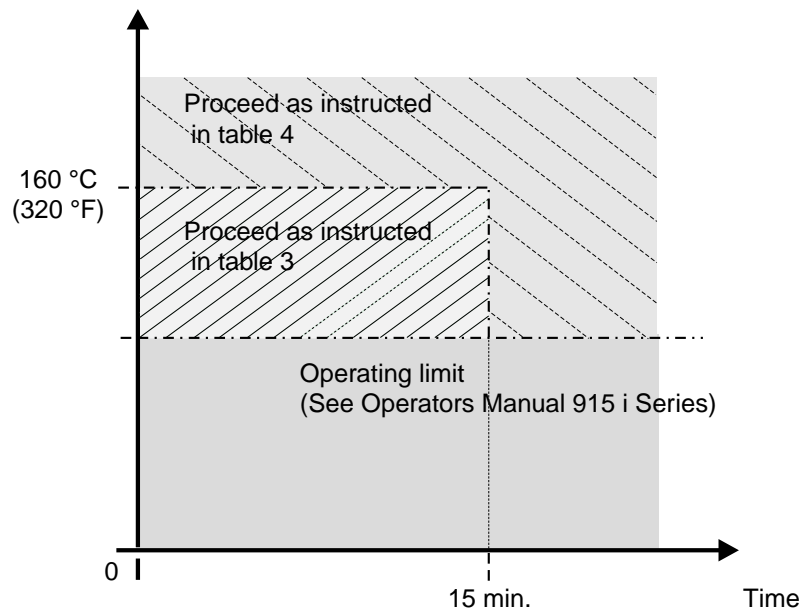

Figure 5.24: Overview and proceed

BRP-Rotax

MAINTENANCE MANUAL LINE

Exceeding up to max. 160 °C (320 °F)

Table 3: Excess temperature up to max. 160 °C (320 °F) max. 15 min.	
Step	Procedure
1	The whole oil system must be inspected, repaired or overhauled in accordance with the BRP-Rotax instructions for continued airworthiness.
2	Inspect oil level in the oil tank.
3	Inspect oil cooler for contamination and check the entire oil circuit for correct functioning.
4	Check that oil lines are routed correctly and undamaged.
5	Cut oil filter housing and inspect filter mat for foreign matter.
6	Carry out oil change.
7	Inspect all further systems for correct functioning.

Exceeding over 160 °C (320 °F)

Table 4: Excess temperature over 160 °C (320 °F) and/or the operating limit for longer than 15 min.	
Step	Procedure
1	The whole oil system must be inspected, repaired or overhauled in accordance with the BRP-Rotax instructions for continued airworthiness.
2	Inspect all further systems for correct functioning.
3	Carry out detailed inspection of the affected engine components.
4	The whole oil system (oil cooler, oil lines) must be inspected.
5	Cut oil filter housing and inspect filter mat for foreign matter.
6	Carry out oil change.

OIL PRESSURE BELOW MINIMUM VALUE

General note

NOTICE

If the oil pressure falls below the minimum value, other limits are often exceeded, e.g. the oil temperature. Please observe the relevant instructions.

NOTE

Any exceeding of the min. admissible oil pressure must be entered by the pilot into the engine log book, stating duration and extent of excessive pressure and pertinent details.

BRP-Rotax
MAINTENANCE MANUAL LINE

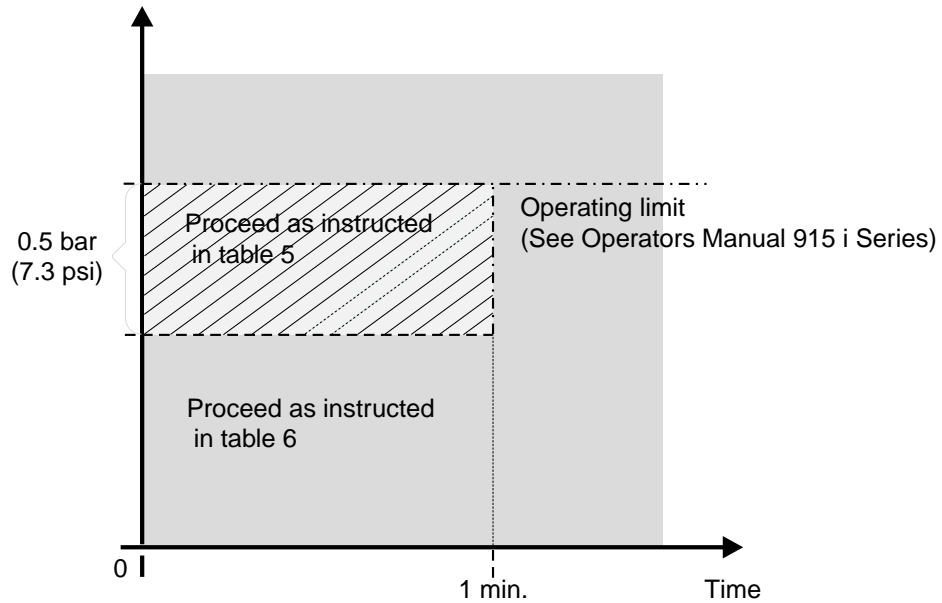

Figure 5.25: Overview and instruction

Oil pressure below minimum oil pressure on the ground

If noticed **on ground**, immediately stop the engine and determine the cause.

- Inspect the complete lubrication system, trace cause and rectify.

If the oil pressure falls below the minimum value up to max. 0.5 bar (7.25 psi) and for max. 1 min., the cause must be determined.

Table 5: Oil pressure below minimum permissible oil pressure up to max. 0.5 bar (7.25 psi) max. 1 min. in flight	
Step	Procedure
1	Inspect all oil lines for restrictions and clear passage.
2	Verify oil quantity.
3	Inspect pressure sensor and connector.
4	Inspect indicating instrument to specifications of the manufacturer, replace as required.
5	Inspect crankcase pressure, see current Installation Manual (IM), Chapter 79-00-00.
6	If no cause for the low oil pressure is found after the above checks, carry out an oil change.

BRP-Rotax
MAINTENANCE MANUAL LINE

Table 5: Oil pressure below minimum permissible oil pressure up to max. 0.5 bar (7.25 psi) max. 1 min. in flight	
Step	Procedure
7	If after the previous checks and oil change the oil pressure is still too low, repair or overhaul the engine in accordance with the BRP-Rotax instructions for continued airworthiness.
8	Inspect all systems for correct functioning.
9	Carry out detailed inspection of the affected engine components.

NOTICE
Replace the oil cooler and oil lines. Before the re-installation of the engine the complete lubrication system (inclusive oil tank) must be flushed.

Minimum oil pressure in flight lower than 0.5 bar (7.25 psi).
Consequent damage can be expected if the oil pressure falls below the minimum value by more than 0.5 bar (7.25 psi). See current Operators Manual (OM).

Table 6: Oil pressure below minimum permissible value more than 0.5 bar (7.25 psi) in flight	
Step	Procedure
1	The whole oil system must be inspected, repaired or overhauled in accordance with the BRP-Rotax instructions for continued airworthiness. • The crankshaft must be replaced.
2	Carry out detailed inspection of the affected engine components.
3	Cut oil filter housing and inspect filter mat for foreign matter.
4	Inspect all further systems for correct functioning.

BRP-Rotax
MAINTENANCE MANUAL LINE

OIL SPECIFICATION NOT RESPECTED

General note NOTE

An entry by the pilot in the engine log book of all pertinent details is required.

If by error engine was serviced with oil, which does not correspond with oil specification in the Operators Manual and the engine has been in operation for **less than 5 hours**, the following measures must be taken:

Less than 5 hr.

Oil specification not respected	
Step	Procedure
1	Carry out an oil change.
2	Remove the lowest positioned screw (banjo bolt, plug screw or screw socket) and drain the remaining oil from the crankcase. Re-install banjo bolt or plug screw.  Tightening torque see current Installation Manual (IM) for the respective engine type.
3	Replace oil filter.
4	Drain oil completely from oil cooler and oil hoses.
5	Drain oil from oil tank.
6	Refill oil tank with oil as specified, see current Operators Manual (OM).
7	Purge air from oil system. See Chapter 12-20-00 section Purging the oil system .
8	Run engine for approx. 1 hour and change oil and oil filter once more, see Chapter 12-20-00 section Oil change .

BRP-Rotax
MAINTENANCE MANUAL LINE

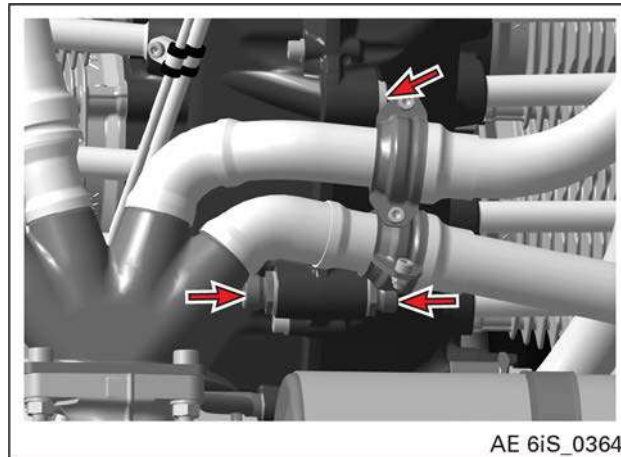



Figure 5.26: Lowest positioned screws

Longer than 5 hr.

If the engine has been operated **longer than 5 hours** with engine oil not corresponding with specification in the Operators Manual (OM) the following work is required.

Oil specification not respected	
Step	Procedure
1	Remove propeller gearbox. See Chapter 05-50-00, section Removal of the propeller gearbox.
2	The gearbox must be inspected, repaired or overhauled in accordance with the BRP-Rotax instructions for continued airworthiness.
3	Carry out detailed inspection of the affected engine components.
4	Carry out an oil change.
5	Remove the lowest positioned banjo screw (banjo bolt, plug screw or screw socket) and drain the remaining oil from the crankcase. Re-install banjo bolt or plug screw.  For tightening torques see current Installation Manual (IM) of the respective engine type.
6	Replace oil filter.
7	Inspect the contact surfaces camshaft / hydraulic valve tappet.
8	Drain oil completely from oil cooler and oil hoses.
9	Drain oil from oil tank.
10	Refill oil tank with oil as specified, refer to Operators Manual (OM) .

BRP-Rotax MAINTENANCE MANUAL LINE

Oil specification not respected	
Step	Procedure
11	Purge air from oil system. See Chapter 12-20-00 section Purging the oil system .
12	Run engine for approx. 1 hour and change oil and oil filter once more, as stated above.

SPARK PLUG NOT IN ACCORDANCE WITH SPECIFICATION

General note If by error any of the spark plugs were installed which are not according to specification of the engine manufacturer and/or not genuine ROTAX® parts, the following verification will be necessary.

Spark plug not in accordance with specification	
Step	Procedure
1	Mark position of the spark plugs (e.g. cylinder 1 top) and remove all spark plugs.
2	Inspect the spark plugs for damage (formation of melt beads, burn off). At heavy melt beads or bad burn off, inspect the piston dome and cylinder wall by borescope. If parts are damaged, the engine must be inspected, repaired or overhauled in accordance with the BRP-Rotax instructions for continued airworthiness.
3	Inspect all systems for correct function.
4	Detailed inspection of affected engine components.
5	Inspect spark plug thread for damage (especially at bad burn off).
6	Differential pressure check. See Chapter 12-20-00 section Checking the compression .
7	Change oil and oil filter.

NON COMPLIANCE OF FUEL QUALITY

General note With the use of unsuitable fuel quality (e.g. low octane fuel), depending on the operating condition the knock control would activate itself. This control should prevent damage by knocking combustion.
The use of unsuitable fuel quality has to be entered in the engine log book.

Independent of subsequent following inspections are required:

BRP-Rotax
MAINTENANCE MANUAL LINE

Non compliance with fuel quality	
Step	Procedure
1	Visual inspection of engine.
2	Empty the fuel system according to the instructions of aircraft manufacturer.
3	Flush fuel system.
4	Check cylinder differential pressure.
5	Engine test run.

SMOOTH PERFORMANCE OF THE ENGINE

General note

⚠ WARNING
Risk of electric shock! Ignition "OFF" and system grounded! Disconnect negative terminal of battery.

Inspection

Inspection of smooth performance of the engine should be performed at a temperature about 0 °C to 60 °C (32 °F to 140 °F).

Engine runs sluggishly	
Step	Procedure
1	Remove spark plug connector and remove 1 spark plug from each cylinder.
2	Torque must be determined with a suitable jig. To do this, determine the maximum occurring torque on the propeller shaft necessary to move the whole crank drive. The torque must be max. 150 Nm (111 ft.lb). If the maximum torque is exceeded, perform the following inspections: <ul style="list-style-type: none">• Carry out detailed inspection of the affected gearbox components• Carry out detailed inspection of crank drive

BRP-Rotax
MAINTENANCE MANUAL LINE

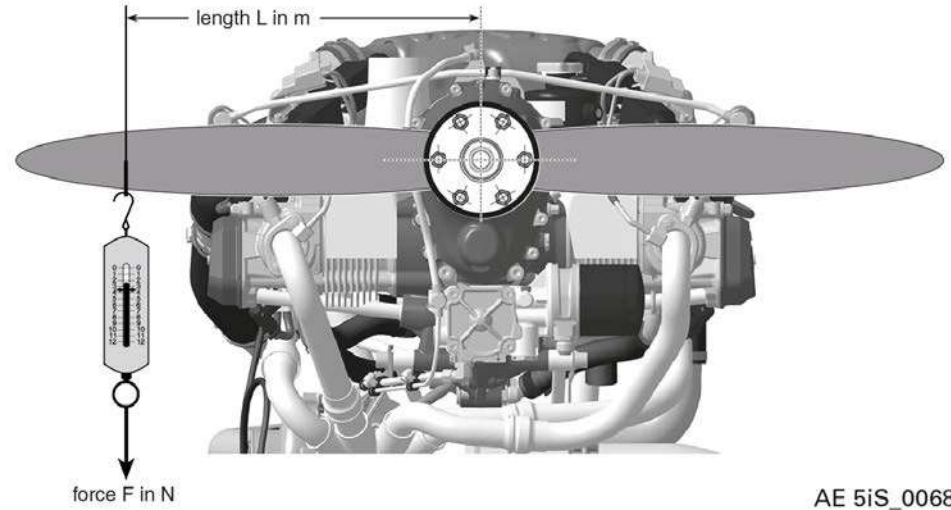

AE 5iS_0068a

Figure 5.27: Inspection of smooth performance TYPICAL

NOTE

Always use protection of propeller edge when doing this test.

BRP-Rotax
MAINTENANCE MANUAL LINE

SUDDEN DROP IN BOOST PRESSURE AND SPEED

General note

NOTICE
If there is damage to the turbocharger, the engine must be sent to the authorized overhaul facility for overhaul.

Sudden drop in boost pressure and speed	
Step	Procedure
1	Visual inspection of the engine, in particular <ul style="list-style-type: none">• Turbocharger• Air intake system• Waste gate function• Pop-off valve• Pressure control valve (PCV) and hoses
2	Check wiring. See Chapter 12-20-00 section Check wiring . NOTE <i>If no mechanical damage is detected during the visual inspection, check the pressure control valve (PCV). See current Maintenance Manual Heavy (MMH), Chapter 76-00-00.</i>
3	Check oil consumption.
4	Oil level check. See Chapter 12-20-00 section Oil level check .

BRP-Rotax
MAINTENANCE MANUAL LINE

SUDDEN INCREASE IN BOOST PRESSURE AND SPEED

General note

⚠ WARNING

Non-compliance can result in serious injuries or death!
The engine must not be taken into operation before having corrected the cause of deficiency.

NOTICE

If the permissible operating limits are exceeded or values fall below the minimum, the corresponding checks must be also be carried out.

Sudden increase in boost pressure and speed

Step	Procedure
1	Visual inspection of the engine, in particular <ul style="list-style-type: none">• Turbocharger• Air intake system
2	Check wiring. See Chapter 12-20-00 section Check wiring . NOTE <i>If no mechanical damage is detected during the visual inspection, check the pressure control valve (PCV). See Chapter 76-00-00 of the Maintenance Manual Heavy (MMH).</i>

BRP-Rotax
MAINTENANCE MANUAL LINE

PERIODIC RISE AND FALL IN BOOST PRESSURE AND SPEED (OSCILLATION OF TURBO CONTROL UNIT)

General note

⚠ WARNING
<p>Non-compliance can result in serious injuries or death!</p> <p>The engine must not be taken into operation before having corrected the cause of deficiency.</p>

NOTICE
<p>If the permissible operating limits are exceeded or values fall below the minimum, the corresponding checks must be also be carried out.</p>

Periodic rise and fall in boost pressure and speed	
Step	Procedure
1	Visual inspection of the engine, in particular <ul style="list-style-type: none"> Turbocharger Air intake system
2	Check wiring. See Chapter 12–20–00 section Check wiring . NOTE <i>If no mechanical damage is detected during the visual inspection, check the pressure control valve (PCV). See chapter 76–00–00 of the Maintenance Manual Heavy (MMH).</i>

LIGHTNING STRIKE

General note An indirect lightning strike is a strike on the aircraft fuselage, the wings or propeller. A direct lightning strike is a strike which acts directly on the engine.

Different types of damage can be caused depending on the type of lightning strike.

Indirect lightning strike Read out the ECU data memory and check the data for details of increased oil temperature. Perform the corresponding inspections/repairs depending on the functional defects found.

Indirect lightning strike	
Step	Procedure
1	Inspect the condition of the engine.
2	Inspect the mechanical actuation systems in the engine.
3	Inspect the electrical wiring and components.

BRP-Rotax
MAINTENANCE MANUAL LINE

Indirect lighting strike	
Step	Procedure
4	Crank the engine and check that it rotates freely.
5	Perform an engine test run.
6	Inspect FUSE BOX.

Heat damage due to indirect lightning strike:

Detailed findings will need to be obtained for affected components. Always replace components if visible signs of damage are evident or if you are in any doubt.

Electrical and magnetic damage due to indirect lightning strike:

Detailed findings will need to be obtained for affected components. Always replace components if visible signs of damage are evident or if you are in any doubt.

Direct lightning strike

NOTICE

After direct lightning strike, the engine has to be overhauled in according to the current Overhaul Manual (OHM) for the respective engine type.

Overhaul Manual (OHM) and its appendix is available for any appropriately rated person or entity on request and by following the standards of the original manufacturer.

CUSTOMER SERVICE INFORMATION REPORT (CSIR)

Online CSIR

In case of any relevant occurrences that may involve malfunction of the engine, click here to fill out a Customer Service Information Report (CSIR):

www.flyrotax.com/p/service/customer-service-information-report

NOTE

This is valid for all ROTAX® Aircraft engines types (certified – according to the regulation of EASA part 21A.3 / FAR 21.3) and non-certified – ASTM compliant, etc.).

BRP-Rotax
MAINTENANCE MANUAL LINE

INTENTIONALLY LEFT
BLANK

BRP-Rotax
MAINTENANCE MANUAL LINE

Chapter: 12-00-00
MAINTENANCE OF THE SYSTEMS

TOPICS IN THIS CHAPTER

Introduction

The section "Maintenance of the systems" is associated with other sections. It serves only as a supplement to and further explanation of the maintenance check list (See Chapter 05-20-00).

NOTE

For reasons of clarity, only headlines and keywords are listed in the Maintenance Schedule. Please refer to the following pages for further explanation if needed. As far as possible, the content has been arranged according to system.

BRP-Rotax
MAINTENANCE MANUAL LINE

INTENTIONALLY LEFT
BLANK

BRP-Rotax
MAINTENANCE MANUAL LINE

Chapter: 12-10-00
REPLENISHING OPERATING FLUIDS

TOPICS IN THIS CHAPTER

Servicing points on the engine	2
Fluid capacities	3
Cooling system	4
Coolant check/replenish	4
Lubrication system	7
Oil level check/Replenish	7

Introduction The engine should always be in a horizontal position before checking the fill levels.

ENVIRONMENTAL NOTE

**All operating materials and cleaning products endanger the environment by
improper disposal.
Dispose of the operating materials in an environmentally sound way!**

SERVICING POINTS ON THE ENGINE

Overview

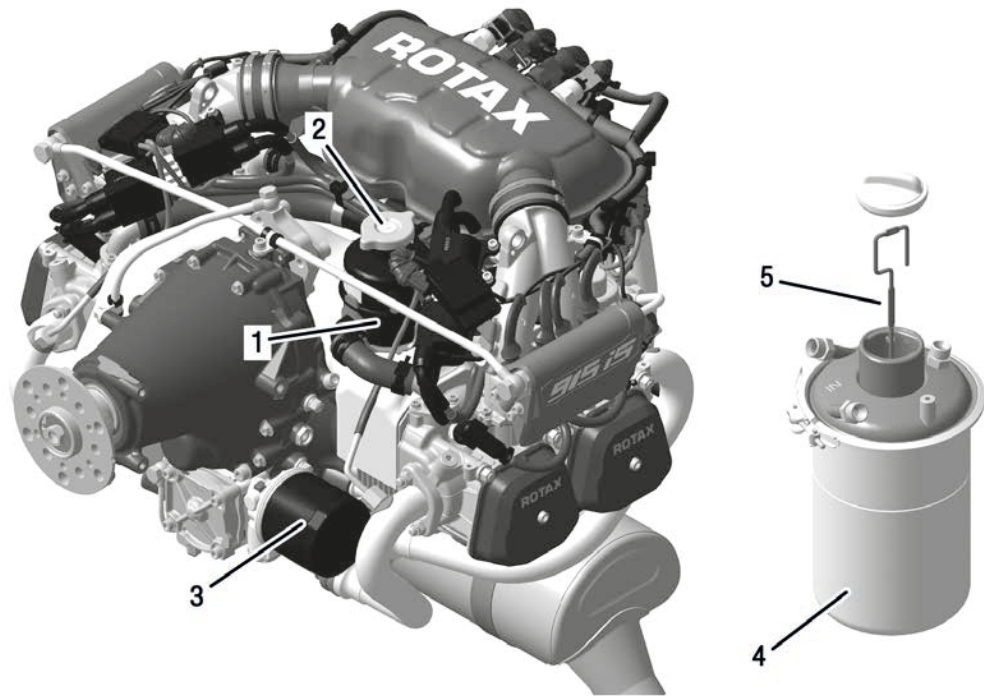

AE 51S_0265

Figure 6.1

- | | | | |
|---|----------------|---|--------------|
| 1 | Expansion tank | 2 | Radiator cap |
| 3 | Oil filter | 4 | Oil tank |
| 5 | Oil dipstick | | |

BRP-Rotax
MAINTENANCE MANUAL LINE

FLUID CAPACITIES

General note

NOTICE
The operation of the engine may be adversely affected if non-approved or contaminated fuel, oil or coolant are used. Any mixing of different manufacturers and types should be avoided. The use of additives may result in damage.

System overview



See Operators Manual (OM) for the respective engine type.

System	Fill capacity	Details about the operating fluids
Fuel system	Refer to the relevant specifications provided by the aircraft manufacturer.	Refer to the corresponding chapter in the Flight Manual.
Cooling system	Approx. 1.5 l (0.4 US gal.).	Refer to the corresponding chapter in the Operators Manual (OM).
Oil system	MIN mark corresponds to 2.5 l (0.66 US gal.) and MAX mark corresponds to 3.0 l (0.8 US gal.).	Refer to the corresponding chapter in the Operators Manual (OM).

NOTE

BRP-Rotax can give an approx value on the fill capacity depending on aircraft design and positions of radiators and tanks. The volume may differ from this value. Always check the relevant specifications provided by the aircraft manufacturer.

COOLING SYSTEM

General note

⚠ WARNING

Risk of burns and scalds. Hot engine parts.
Always allow engine to cool down to ambient temperature before starting work.

⚠ WARNING

Risk of Burns!
Never open the radiator cap when the cooling system is hot. For safety's sake, cover cap with a rag and open slowly. Sudden opening of the cap could provoke the escape of boiling coolant and result in scalding.

ENVIRONMENTAL NOTE

Coolant and mixtures of coolant and water have to be treated as hazardous waste!

COOLANT CHECK/REPLENISH

Special tool

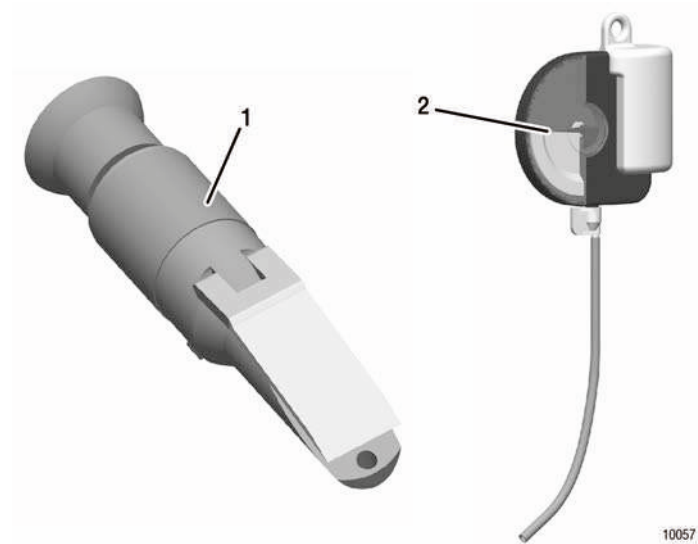

Figure 6.2: Special tool

Part number	Description
part no. n.a	Densimeter (1)
part no. n.a	Glycol tester (Refractometer) (2)

BRP-Rotax MAINTENANCE MANUAL LINE

Instruction

To refill the coolant the following steps are necessary.

Step	Procedure
1	Open the radiator cap (1) on the expansion tank (2). Visually check the rubber seats inside the cap for condition and orientation.
2	Check the coolant level. The coolant level must be filled up to the top..
3	Inspect coolant with densimeter or glycol tester. Strongly discolored or thickened coolant must be replaced.

NOTICE

Use only coolant as recommended in the current Operators Manual (OM) and SI-915 i-001 "Selection of suitable operation fluids", current issue.

Step	Procedure
4	If necessary, replenish with coolant of same composition.
5	Apply small amount of coolant to rubber surfaces inside cap (provides lubrication to prevent binding). Tighten the radiator cap by hand.

NOTE

The radiator cap must be tightened until the stop lug is contacted.

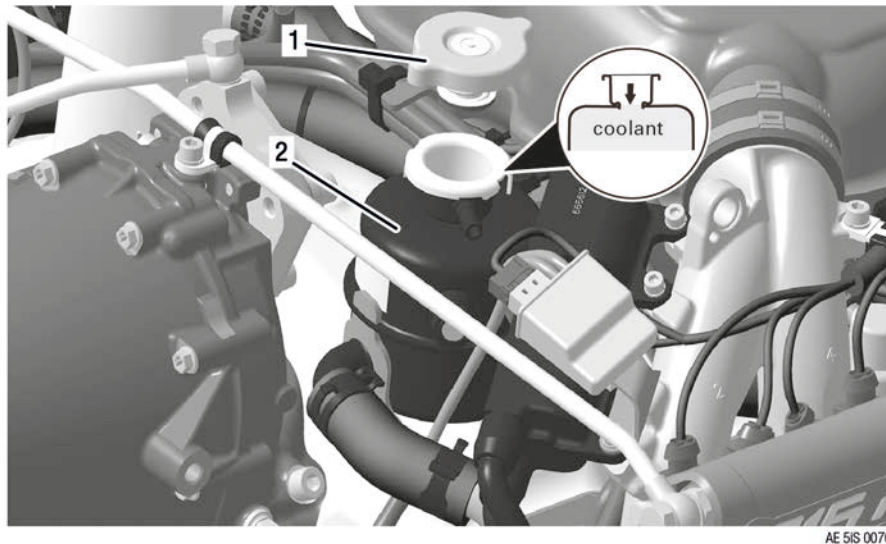

Figure 6.3: Coolant check/replenish

1 Radiator cap

2 Expansion tank

BRP-Rotax
MAINTENANCE MANUAL LINE

Engine test run Engine test run is necessary:

Step	Procedure
1	Operate the engine until the temperatures have stabilized for a period of 5 min. (engine oil temperature between 50 to 70 °C (122 - 160 °F).
2	Switch the engine OFF.
3	Allow the engine to cool down.
4	Check for leaks.
5	Check the coolant level and top up with coolant as required.

BRP-Rotax
MAINTENANCE MANUAL LINE

LUBRICATION SYSTEM

General note

⚠ WARNING

Risk of burns and scalds. Hot engine parts.
Always allow engine to cool down to ambient temperature before starting work.

⚠ WARNING

Risk of electric shock!
Ignition "OFF" and system grounded! Disconnect negative terminal of battery.

ENVIRONMENTAL NOTE

Protect the environment.
Do not harm the environment by spilling oil. Dispose of oil in an environmentally friendly manner.

OIL LEVEL CHECK/REPLENISH

Preparatory tasks Before checking the oil level, make sure that there is no excessive residual oil in the crankcase.

Instruction For checking and before replenish proceed as follows.

Step	Procedure
1	Remove cap from oil tank.
2	Turn the propeller several times by hand in direction of engine rotation to pump residual oil from the engine to the oil tank.
3	This process is completed when air flows back to the oil tank. This air flow can be perceived as a murmur (gurgling) when the oil tank cover without venting is removed.
4	Pull out the oil dipstick (2).
5	The oil level in the oil tank should be between the two marks (max./min.) on the oil dipstick, but must never fall below the min. mark.
6	During standard engine operation, the oil level should be mid-way between the max. and min. marks, as at higher oil level (over servicing), oil will escape via the venting passage. Difference between "max." and "min". - mark = 0.60 l (1.27 liq.pt).

BRP-Rotax
MAINTENANCE MANUAL LINE

NOTICE

For longer flights replenish oil to max. mark to warrant more oil reserve.

NOTICE

Only use brand name oil in accordance with the current Operators Manual (OM) and current SI-915 i-001 "Selection of suitable operation fluids".

Step	Procedure
7	Replenish oil as required.
8	Check oil level - Marks on the oil dipstick.
9	Fit the oil dipstick and tighten the oil tank cover (1) by hand.

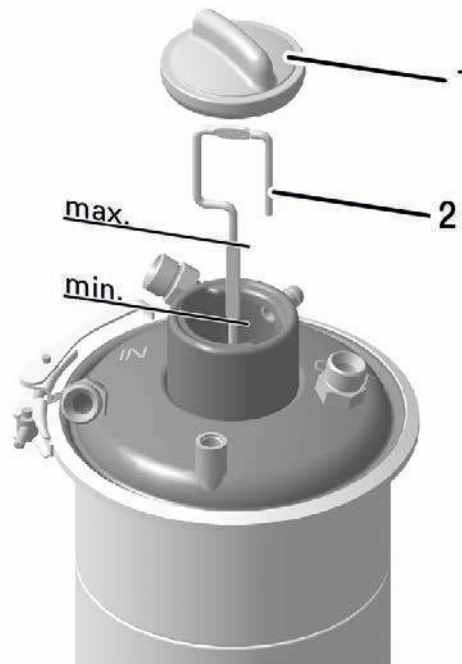

AE 5IS 0071

Figure 6.4: Oil level check/Replenish

1 Oil tank cover, without venting

2 Oil dipstick

BRP-Rotax
MAINTENANCE MANUAL LINE

Engine test run An engine test run is necessary:

Step	Procedure
1	Check the oil level and top up with oil as required.
2	Operate the engine until the temperatures have stabilized for a period of 5 min. (engine oil temperature between 50 to 70 °C (122 - 160 °F).
3	Switch the engine OFF.
4	Allow the engine to cool down.
5	Check for leaks.

BRP-Rotax
MAINTENANCE MANUAL LINE

INTENTIONALLY LEFT
BLANK

BRP-Rotax
MAINTENANCE MANUAL LINE

Chapter: 12-20-00
SCHEDULED MAINTENANCE

TOPICS IN THIS CHAPTER

Engine cleaning	3
Visual inspection	4
Checking the engine suspension	4
Corrosion.....	5
Leakage check	6
Differential and crankcase pressure check	8
Engine control unit (ECU)	13
Checking ECU	13
Read out the ECU data memory	14
Checking the AC-DC Converter warning lamps.....	14
Lock/Loosen the crankshaft	15
Test run of engine	17
Cooling system	19
Checking the cooling system	20
Replacing the coolant	21
Flushing the cooling system	23
Expansion tank, radiator cap	24
Fuel system	25
Leak tests	26
Checking the fuel lines	26
Checking the fuel pressure regulator.....	26
Fuel injectors	27
Fuel rail	27
Lubrication	28
Oil change	30
Oil filter - removal	31
Inspecting of the oil filter components.....	33
New oil filter - installation.....	36
Cleaning the oil tank	37
Purging the oil system.....	39
Flushing the oil circuit	39
Inspecting the magnetic plug	41
Installation of the magnetic plug.....	42
Electric system	43
Check of wiring.....	45
Replacement of spark plugs	46
Remove the spark plugs	46
Inspection of spark plugs.....	46
Installation of spark plug	48
Fuse box.....	49
Turbocharger	50

BRP-Rotax
MAINTENANCE MANUAL LINE

Checking and cleaning plug screw (turbo oil sump assy.).....	50
Propeller gearbox	52
Checking the propeller gearbox	52
Check POP-OFF VALVE	54

Introduction This chapter relates in particular to the maintenance work mentioned in the Maintenance Schedule for the various engine systems and covers the work in more detail.

ENGINE CLEANING

General note

ENVIRONMENTAL NOTE

When cleaning the engine, the dissolved residues of fuel, oil and other environment-contaminating agents are rinsed off.
Collect the residual liquids and dispose of them in an environmentally sound way.

NOTICE

Do not use flammable liquids or caustic cleaning agents for cleaning the engine.

Cleaning agents

Use of a commercially available cold cleaning agent for the engine is recommended.
See [Chapter 05-00-00 section Consumable Materials](#).

Cleaning

NOTICE

Never clean an engine with a high pressure cleaner. This is detrimental to the electrical installations and shaft seals. Oxidation of the various components and their potential failure may occur.

NOTICE

Before cleaning, all openings through which cleaning agents and/or dirty water could enter the engine must be closed off.
Failure to do this may result in engine damage!

NOTE

Always clean engine in cold state.

The engine must always be cleaned with due care and attention to detail. Plug openings as required before cleaning.

After each cleaning

After each cleaning procedure, dry all electrical components such as

- Battery
- Ignition unit
- Spark plug connector
- Clamp connections etc.
- ECU and Fuse box + connections

by use of compressed air to prevent increased electrical resistance caused by corrosion.

BRP-Rotax
MAINTENANCE MANUAL LINE

VISUAL INSPECTION

General note General visual inspection of the engine for damage or abnormalities. For definition and scope of visual inspection. See [Chapter 05-20-00 section Visual inspection](#).

Abnormalities Take note of changes caused by temperature influence.
During a visual inspection you should focus on the following points in particular:

- Exhaust system
- Engine suspension frame
- Heat shrink sleeve
- Sensor technology
- Oil filter
- FUSE BOX
- Venting hoses (oil tank)
- Airbox
- Fuel line (steel)
- Wiring harness
- Coolant hoses
- ECU

NOTE

On turbocharger

- Turbocharger with attachment

Step	Procedure
1	Only a visual inspection is necessary.
2	Check compressor impeller for mechanical damage and free movement.
3	Check turbo housing for cracks.

CHECKING THE ENGINE SUSPENSION

General note

NOTICE

Be sure to use the recommended tightening torque for the specified fastener.

Checking the engine suspension

1. Verify the engine suspension points on the crankcase for tight fit and damage including cracks.
2. Inspect the surroundings of engine attachment on crankcase and gearbox. If there is discoloration of the crankcase around the attachment points (black ring), there may be loose attachments.
3. Inspect engine isolating mounts (rubber buffers) for damage, wear and cracks.
4. Inspect engine suspension frame.

BRP-Rotax
MAINTENANCE MANUAL LINE

CORROSION

Definition

Corrosion is a natural process which attacks and potentially damages metals via an electrochemical reaction. For more detailed information about different types of corrosion and corresponding methods for dealing with corrosion refer to the FAA Advisory Circular AC 43.13. See chapter “AC 43.13-1B Maintenance and Repair”.

BRP-Rotax
MAINTENANCE MANUAL LINE

LEAKAGE CHECK

General note

NOTICE

Leaking connections can lead to engine problems or engine failure!

Visual inspection of the whole engine for leaks. If leaks are visible, locate the cause and remedy the fault.

Water pump

Checking water pump for leaks.

If the leakage bore, located at the base of the ignition housing, is dripping oil (see step 4), the oil seal on the water pump shaft may be defective and must be replaced. In the case of coolant drips at the leakage bore (see step 4), the coolant mechanical seal must be replaced.

NOTE

The internal rotary seal has ceramic sealing surface which is lubricated by the cooling liquid. Therefore signs of dried coolant liquid (like discolouration,...) at the leakage bore is normal. If a coolant leak is suspected, the following steps must be taken:

Step	Procedure
1	Clean the engine.
2	Operate the engine until the temperatures have stabilized for a period of 5 min. (engine oil temperature between 50 ° to 70 °C (122 ° - 158 °F).
3	Switch "OFF" ignition and secure engine against unintentional operation. Secure aircraft against unauthorized operation.
4	For a period of 1 minute after the engine has been stopped, no liquid must drip down.

Coolant hoses

Check coolant hoses and connections and fittings for leakage. Examine the surrounding area to see if there are any leaks.

Hose clamps, kinks

Check all hoses, particularly in the area of the hose clamps and hose connections, for porosity, damage and kinks. If damage is detected, replace hose before further flight.

Fuel line

Inspect fuel line (steel), their connections and screw fasteners. Look for scuffing marks or other damage.

NOTICE

Avoid overtorquing the connections and fasteners. Always comply with the specified torque!

Complete a detailed visual inspection. When checking steel fuel lines (1), pay attention to the connection areas (2). Look for leaks and cracks.

BRP-Rotax
MAINTENANCE MANUAL LINE

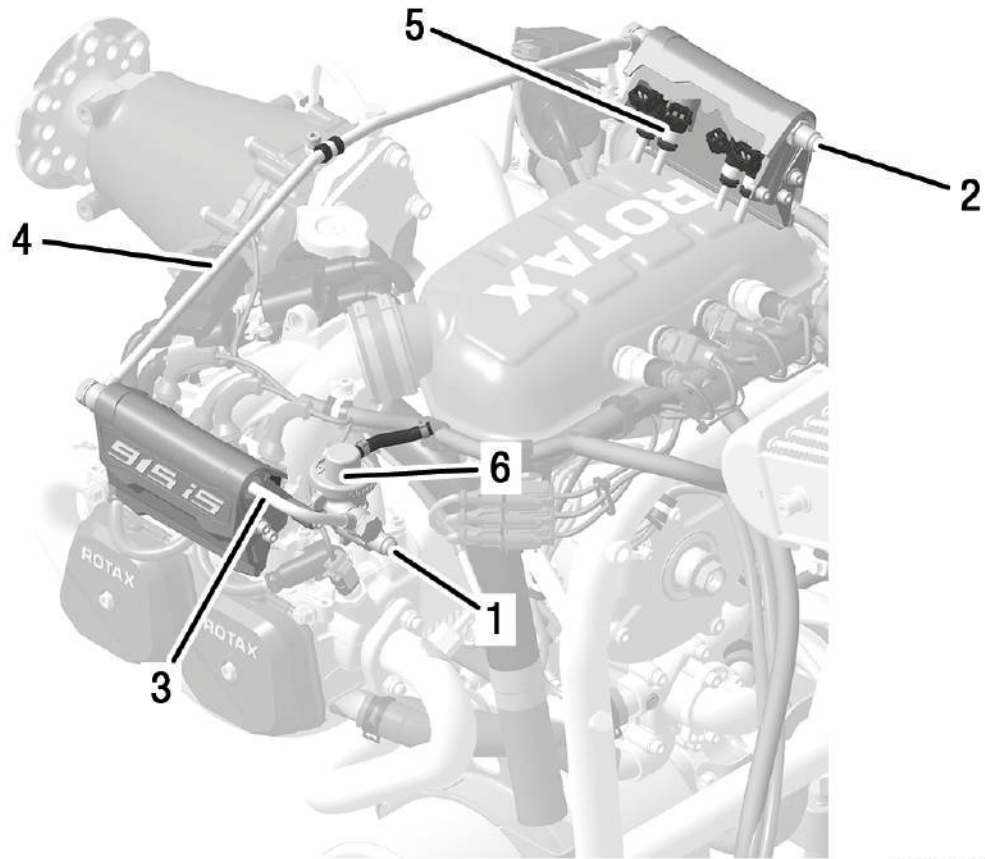

AE 5IS_0144a

Figure 7.1: Connections and fuel lines

- | | |
|-----------------------------|---------------------------|
| 1 Fuel rail 2/4 outlet line | 2 Fuel rail 1/3 feed line |
| 3 Fuel rail | 4 Fuel hose assy. |
| 5 Fuel injector | 6 Pressure regulator |

DIFFERENTIAL AND CRANKCASE PRESSURE CHECK

General note

⚠ WARNING

Risk of electric shock!
Ignition "OFF" and system grounded!

⚠ WARNING

Danger of life threatening injuries caused by the propeller, rotating and stressed parts of the engine!

Engine (and propeller) may suddenly rotate if the piston is not at top dead center. Always secure propeller and keep blade path clear before adding pressurized air to the cylinder.

BRP-Rotax
MAINTENANCE MANUAL LINE

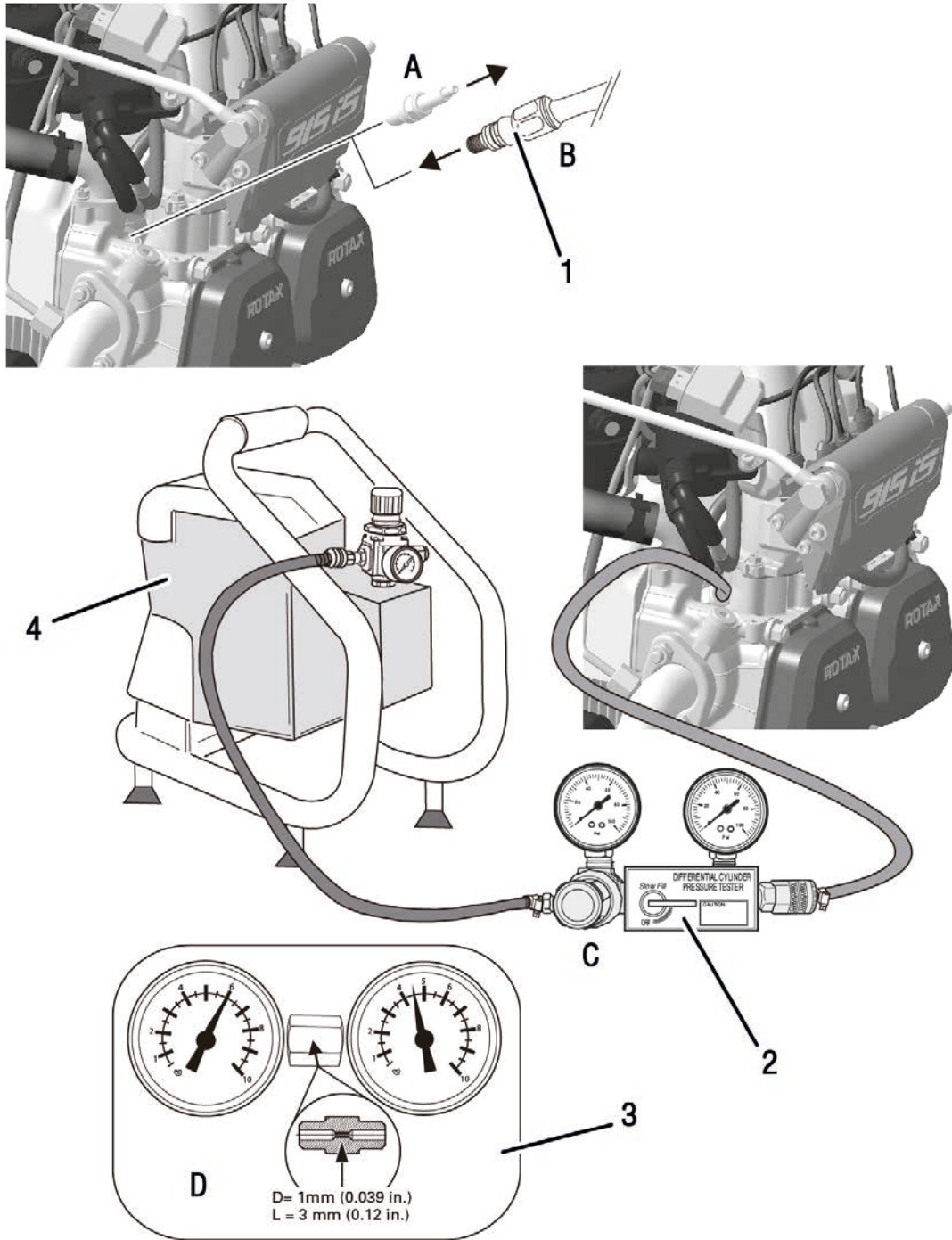

AE 5IS0072

Figure 7.2: Checking the compression. TYPICAL

- | | |
|---------------|-----------------------------|
| 1 Adaptor | 2 Manometer/Test gauges set |
| 3 Orifice jet | 4 Compressor |

BRP-Rotax MAINTENANCE MANUAL LINE

Special tools

To measure the differential pressure the following special tools and equipment are necessary.

Part number	Description
n.a	Compressed air approx. 6 bar (87 psi).
n.a	2 pressure gauges.
n.a	Orifice jet*, of 1 mm (0.04 in) inner diameter and 3 mm (0.12 in) length. * or equivalent e.g. orifice diameter 0.040 in., long 0.0250 in., 60° degree approach angle according to AC43.13, latest issue.
n.a	Adapter to spark plug thread.
n.a	Connect line.

Instruction

Testing is carried out using the **differential pressure test procedure**.

Step	Procedure
1	Operate the engine until the temperatures have stabilized for a period of 5 min (engine oil temperature between 50 to 70 °C (122 - 160 °F).
2	Remove the upper or lower spark plugs. Prevent dirt or other foreign particles from penetrating the engine (A).
3	Starting with cylinder head 1 move piston to TDC position.
4	Screw adaptor (1) into the spark plug thread and connect up the two pressure gauges (2) with the orifice jet (3) between them (B).
5	Now put constant pressure, between 5.5-6 bar (80 - 87 psi) on the line and take readings at pressure gauge (C).
6	Repeat this proceeding at all 4 cylinder heads.

Value

The maximum permissible pressure drop is 45 %. The maximum permissible pressure drop difference between all cylinder heads is 20 %.

Procedure if maximum permissible pressure drop is out of range:

Recheck the readings after operating the engine in a test run for at least 3 minutes. This will allow the piston rings to be wetted with oil. Measure the pressure drop again as described in the differential pressure test procedure. If the pressure loss is still out of range, valve seat debris removal procedure must be carried out.

Valve seat debris removal procedure

Step	Procedure
1	Remove the valve cover according to the current Maintenance Manual Heavy (MMH) for the respective engine type.
2	Turn the crankshaft into the position, so that the intake valve is closed.

BRP-Rotax MAINTENANCE MANUAL LINE

Step	Procedure
3	Place a plastic drift (2) on the rocker arm (1) (directly over the inlet valve stem). See Fig. Valve seat debris removal .
4	During this step the cylinder must be pressurized by using the setup used for the differential pressure check to allow carrying away debris from the valve seat. Use a hammer to give a slight blow onto the fibre drift to dislodge any foreign material between the intake valve face and seat.
5	Turn the crankshaft into a position, so that the exhaust valve is closed and perform step 3 and 4 for the exhaust valve.
6	Install valve cover according to the current Maintenance Manual Heavy (MMH) for the respective engine type.
7	Measure the pressure drop again as described in the differential pressure test procedure.

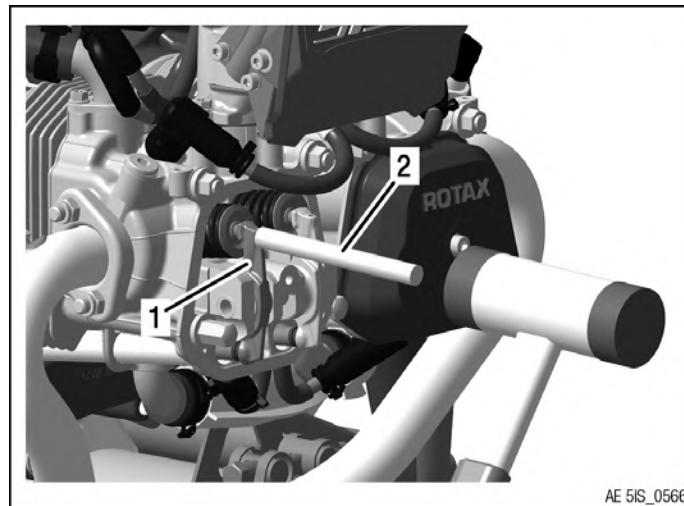

Figure 7.3: Valve seat debris removal

1 *Rocker arm*

2 *Plastic drift*

Troubleshooting

If the pressure drop value and/or the difference between any cylinder are still out of range a crankcase measurement shall be performed to identify any potential problems with the piston ring seal.

Also following troubleshooting reasons might be applicable but are not exclusively limited to:

- Excessive cylinder wall and/or piston ring wear
- Broken piston rings
- Burned valves
- Piston damage

BRP-Rotax
MAINTENANCE MANUAL LINE

**Crankcase
pressure
check**



For crankcase pressure check see current Installation Manual (IM) for the respective engine type, Chapter 79-00-00, section Crankcase pressure measurement.

NOTICE

If used leaded fuel (AVGAS) more than 30% of operation:

Crankcase pressure check has to be performed to determine the degree of deposits around the piston rings.

NOTICE

Exceeded pressure readings:

If crankcase pressure readings were exceeded, the pistons need to be removed, cleaned and inspected according to the current Maintenance Manual Heavy (MMH). If the wear limits are out of the specified range, the pistons must be replaced. Also new piston rings have to be installed.

ENGINE CONTROL UNIT (ECU)

Safety notice

⚠ WARNING

Non-compliance can result in serious injuries or death!
When working on the ECU, the general safety instruction must be observed. See chapter „INTRO“.

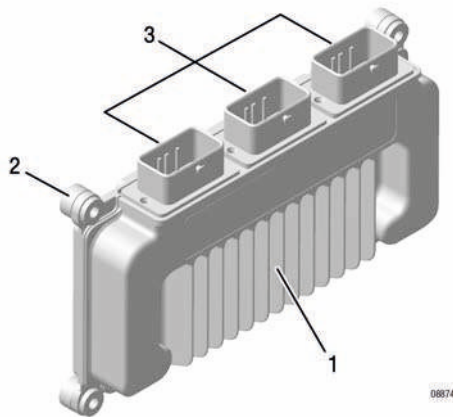

Figure 7.4: Engine control unit (ECU)

- 1 Engine control unit (ECU)
- 2 Rubber isolator
- 3 Socket for AMP-connector

CHECKING ECU

Instruction

For checking proceed as follows:

Step	Procedure
1	Inspect the ECU (1) and ECU mounts (2) for secure attachment and damage.
2	Inspect the ECU wiring for wear, chafing and other damage, and make sure that the connectors are securely attached.

BRP-Rotax MAINTENANCE MANUAL LINE

READ OUT THE ECU DATA MEMORY

Instruction To read out the ECU data memory proceed as follows:

Step	Procedure
1	Connect the decoding unit (Dongle) with ECU data cable to the computer.
2	Select the menu item BUDS in the maintenance software and print out the report.

NOTE

Connect and disconnect the B.U.D.S. USB-to-CAN Converter only if ECU is OFF. Non-compliance leads to entries in the error / event memory of the ECU.



See current Maintenance Manual Heavy (MMH) for the respective engine type, Chapter 76-10-00.

NOTICE

Plausibility check of sensors and actuators (in case of doubt).

Sensors and actuators are automatically checked by the ECU at every power cycle. The ECU also continuously verify all the engine parameters for proper indication. There is no need for further checks, but in case of doubt check in your display the sensors (MAT, MAP, etc) for plausibility e.g. on ground when engine is not running in reference to the environment conditions and/or see the current Maintenance Manual Heavy (MMH) Chapter 76-70-00 for the respective engine type.

CHECKING THE AC-DC CONVERTER WARNING LAMPS

Instruction

Step	Procedure
1	Turn "ON" the Battery. The 14 V output (EMS) and 28 V output (AC) warning lamp should be illuminated.
2	Activate the start power switch. The start power and the 28 V output warning lamps should be illuminated. The 14 V output (EMS) should turn "OFF".
3	Start the engine and deactivate the starter power switch. Let the engine run on 3000 rpm for 2 minutes. All three warning lamps should stay "OFF".

NOTE

In case the warning lamps stay "ON", the wiring and electric components of the power supply have to be checked and corrected.

LOCK/LOOSEN THE CRANKSHAFT

Lock the crankshaft

⚠ WARNING

Risk of burns and scalds. Hot engine parts.
Always allow engine to cool down to ambient temperature before starting work.

Special tool

For accomplishment the following special tool is required:

NOTICE

Do not use any other tool such as a bolt, several damage may occur.



Figure 7.5: Special tool

Part number	Description
240880	Locking pin (1)

Instruction

The following work procedures are to be accomplished:

Step	Procedure
1	Remove the Allen screw (1) M8x20 and sealing ring from the crankcase half (cyl. 2/4).
2	Turn crankshaft/propeller shaft until the piston of cyl. no. 1 and no. 2 are in TDC position and lock crankshaft in this position with the thread bolt (2) part no. 240880. NOTE <i>The required recess position of the crankshaft can be additionally verified by looking through the crankcase recess (3) with a flash light or borescope.</i>
3	Screw the locking pin (2) into the crankcase. While doing so, move the crankshaft slightly with the ring spanner or propeller until the locking pin (2) engages in the recess of the crankshaft. Tighten it to 10 Nm (89 in.lb).

BRP-Rotax
MAINTENANCE MANUAL LINE

NOTICE

Check that the propeller shaft can not be turned in either direction, if it moves – the pin is not in the correct position and damage may occur.

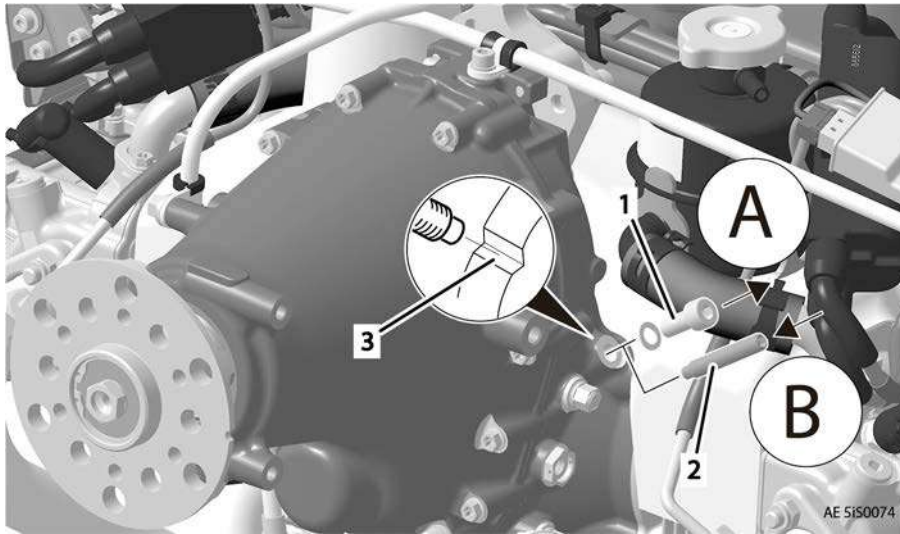

Figure 7.6: Lock/Loosen the crankshaft. TYPICAL

- 1 *Allen screw M8x20 (crankcase) with sealing ring 8x13*
- 2 *Locking pin*
- 3 *Crankshaft*

Loosen the crankshaft

After completion of work/check:

Step	Procedure
1	Remove the locking pin (2) and refit Allen screw M8x20 (1) along with a new sealing ring 8 with a tightening torque of 15 Nm (133 in.lb).

BRP-Rotax
MAINTENANCE MANUAL LINE

TEST RUN OF ENGINE

General note

⚠ WARNING
Danger of life threatening injuries caused by the propeller, rotating and stressed parts of the engine!
Always observe the engine from a safe place while it is running. Check that the cockpit is occupied by a competent operator.

Preparation

Preparation of the engine for test run:

- Ensure that all the operating fluids (engine oil, coolant, fuel) are replenished to the specified level.
- Make sure that no loose objects (e.g. tools) are left in the engine compartment.
- Inspect tight fit of the propeller.
- Anchor the aircraft suitably to the ground and fix wheel chocks. Ensure that the propeller zone is clear and safe before starting the engine.

Test run

Test run as follows



For the special checks, see current Operators Manual (OM) for the respective engine type.

Step	Procedure
1	Engine start according to current Operators Manual (OM).
2	After engine start, observe oil pressure. Oil pressure has to be built up within 10 sec.
3	Let engine run for approx. 2 min. at 2000 rpm. Then first use the throttle lever to bring the engine to approx. 2500 rpm and then run through warming up period, until the oil temperature reaches 50 °C (122 °F).
4	Check temperatures and oil pressure: At a steady oil temperature above 50 °C (122 °F) and oil pressure above 2 bar (29 psi) engine speed may be increased.
5	Ignition lane check as per current Operators Manual (OM).
6	Conduct a short full throttle run and check that the engine reaches the max. full power speed. Consult the pilot's operating handbook for maximum speed, as it depends on the propeller used.
7	After full-load run, conduct a cooling run of minimum 2 minutes to prevent coking of oil in the turbo and formation of vapor lock in cylinder heads. This is also necessary to prevent vapor lock in the cooling and fuel system after shut-down.

BRP-Rotax
MAINTENANCE MANUAL LINE

Step	Procedure
8	Shut engine down. NOTE <i>Switch "OFF" lanes, fuel pumps and master switch</i>
9	Inspect rotary seal for leakage. NOTE <i>Due to the design of the rotary seal, the manufacturer tolerates a certain amount of leakage. If the leakage is in excess of the limit rotary seal must be renewed.</i> Tolerated leakage: For this check the engine must be operated until all temperatures have stabilized for a period of 5 minutes. At that point shut down engine and ensure the ignition is switched "OFF" and engine secured against unintentional operation. Coolant must not drip through leakage bore, located at the base of the ignition housing, for a period of 1 minute after the engine has been stopped. In case this leakage test can not be passed, the rotary seal must be replaced.

Engine oil and coolant

⚠ WARNING
Risk of Burns! Never open the radiator cap when the cooling system is hot. For safety's sake, cover cap with a rag and open slowly. Sudden opening of the cap could provoke the escape of boiling coolant and result in scalding.

Replenish engine oil and coolant as required once engine has cooled down.

Oil filter

NOTICE
If the oil filter has been replaced, re-tighten by hand after the test run on a cold engine.

Check of leaks

Inspect the engine for oil, fuel or coolant leaks and repair as necessary.

BRP-Rotax
MAINTENANCE MANUAL LINE

COOLING SYSTEM

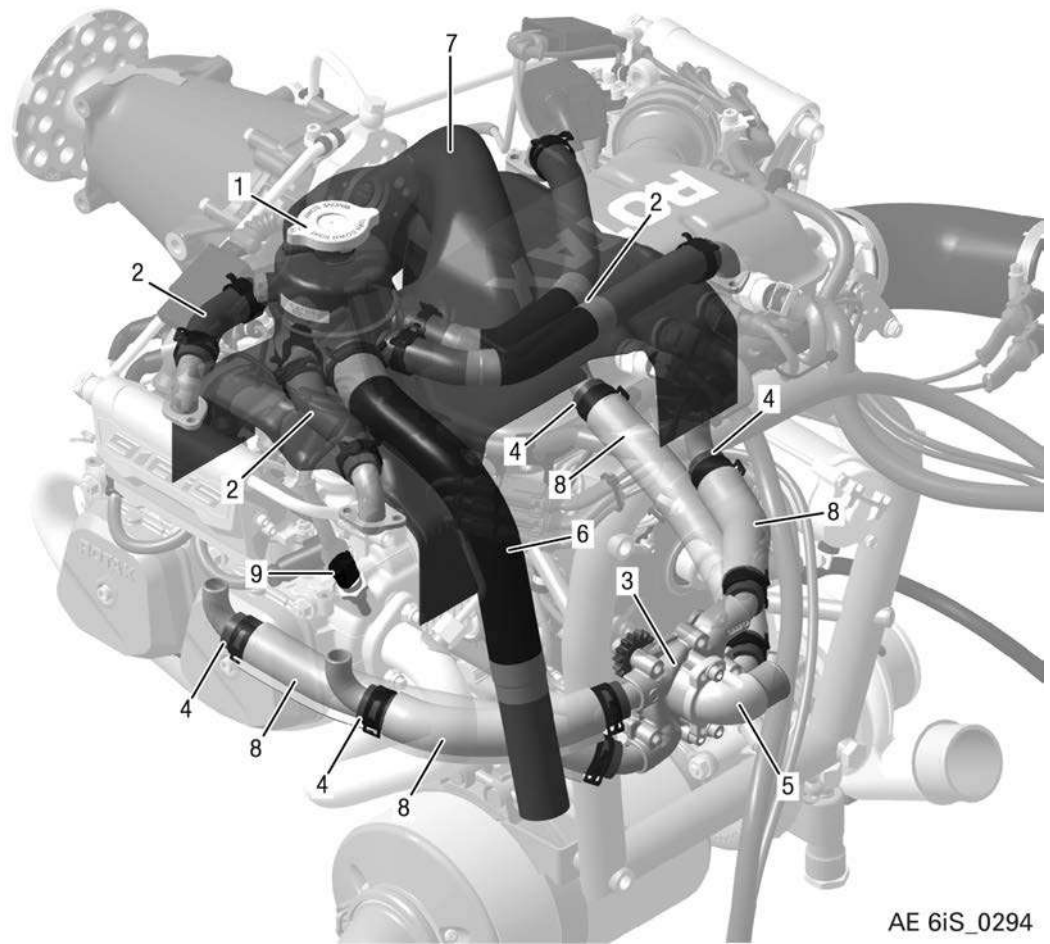

AE 6iS_0294

Figure 7.7: Overview, TYPICAL

- | | | | |
|---|----------------------------------|---|-----------------|
| 1 | Expansion tank assy. | 2 | Form hose |
| 3 | Water pump housing | 4 | Water hose |
| 5 | Water inlet elbow | 6 | Form hose |
| 7 | Cooling air baffle | 8 | Protection tube |
| 9 | Coolant Temperature Sensor (CTS) | | |

BRP-Rotax
MAINTENANCE MANUAL LINE

CHECKING THE COOLING SYSTEM

General note See Figure Overview.

⚠ WARNING

Risk of burns and scalds. Hot engine parts.
Always allow engine to cool down to ambient temperature before starting work.

⚠ WARNING

Non-compliance can result in serious injuries or death!

Any of the following conditions require a check of the cooling system/radiator cap check as described in Chapter 05-50-00 Unscheduled Maintenance.

- unusual high coolant temperatures (exceeded limits)
- reported unusual higher coolant consumption
- any visual signs of coolant leakages in the engine area
- high amount of deposits in the cooling system

NOTICE

If any component in the cooling system requires replacement, a check according to Chapter 05-50-00 Unscheduled Maintenance is recommended.

Coolant hoses	Carry out visual inspection of all form hoses (2) for damage, leaks, hardening as a result of heat and porosity.
Water pump	Inspect all connections on the top and bottom of the cylinder head and on the water pump (3).
Expansion tank	Inspect expansion tank (1) for damage. Inspect protection rubber at the bottom of the tank for tight fit.
Radiator cap	Inspect the gasket of the radiator cap (1) and check the pressure release valve and return valve for proper operation. See Chapter 12-20-00 section Expansion tank, Radiator cap.

REPLACING THE COOLANT

General note

⚠ WARNING

Risk of Burns!

Never open the radiator cap when the cooling system is hot. For safety's sake, cover cap with a rag and open slowly. Sudden opening of the cap could provoke the escape of boiling coolant and result in scalding.

NOTICE

Use only coolant as recommended in the current Operators Manual (OM) and SI-915 i-001 "Selection of suitable operation fluids", current issue.

ENVIRONMENTAL NOTE

Protect the environment!

Do not harm the environment by spilling coolant. Dispose coolant in an environmentally friendly manner.

Instruction

To replace the coolant the following steps are necessary:

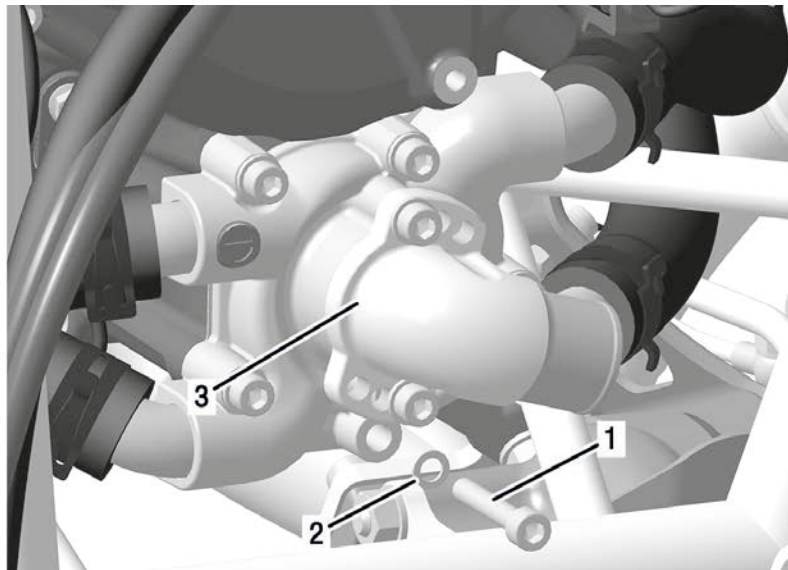

AE 5iS0078

Figure 7.8: Replacing the coolant

- 1 Allen screw M6x35 (stainless steel)
- 2 Gasket ring
- 3 Water pump

BRP-Rotax
MAINTENANCE MANUAL LINE

Step	Procedure
1	Open the radiator cap on the expansion tank.
2	Remove the bottom Allen screw (1) (with gasket ring (2)) of water pump (3).
3	Drain the engine coolant. NOTE <i>If the radiator is located below the engine, also detach the lowest positioned coolant hose.</i>
4	Fit Allen screw (stainless steel) along with a new gasket ring. Tighten to 10 Nm (89 in.lb).
5	If the coolant is being replaced with a different type, (OAT, IAT) the cooling system must be flushed. See Chapter 12-20-00 section Flushing the cooling system.
6	Refill newly mixed coolant into the expansion tank (highest point of the cooling system). See Chapter 12-10-00 section Coolant check/replenish.
7	Fit radiator cap.
8	NOTE <i>Run the engine briefly and replenish with clean coolant as required.</i>

BRP-Rotax
MAINTENANCE MANUAL LINE

FLUSHING THE COOLING SYSTEM

General note

⚠ WARNING

Risk of Burns!

Never open the radiator cap when the cooling system is hot. For safety's sake, cover cap with a rag and open slowly. Sudden opening of the cap could provoke the escape of boiling coolant and result in scalding.

Instruction

To flush the coolant the following steps are necessary:

Step	Procedure
1	Open the radiator cap on the expansion tank.
2	Open the lowest located coolant hose (either at water pump or radiator)
3	Flush the system from the open expansion tank down to the open coolant hose using pure (alternative is distilled) water. NOTE <i>It is recommended to use a pump for flushing of the cooling system with water under pressure.</i>
4	Let residual water drain and reconnect the lowest located coolant hose.
5	Refill newly mixed coolant into the expansion tank (highest point of the cooling system). See Chapter 12-10-00 section Coolant check/replenish .

NOTICE

If water-free coolant is used, the cooling system must be flushed and refilled with conventional coolant.

Step	Procedure
6	Fit radiator cap.
7	NOTE <i>Run the engine briefly and replenish with clean coolant as required.</i>

EXPANSION TANK, RADIATOR CAP

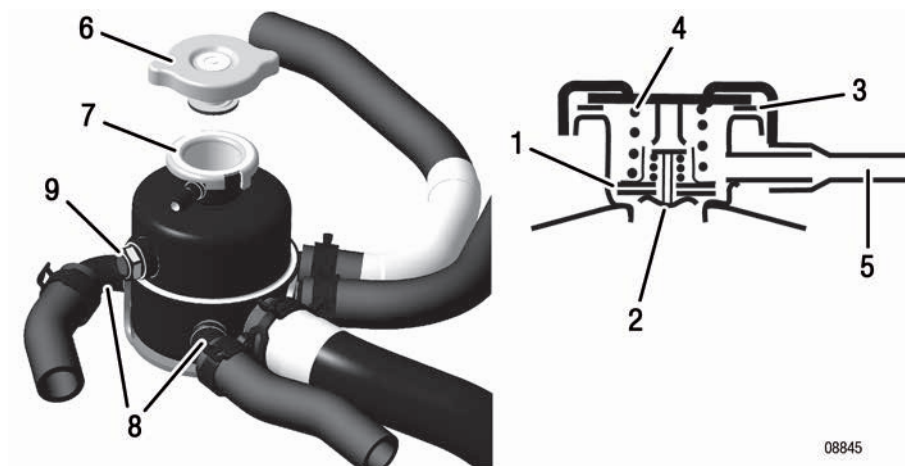

Figure 7.9: Expansion tank, radiator cap

- | | | | |
|---|-------------------------------|---|--------------------------------------|
| 1 | Pressure relief valve | 2 | Return valve |
| 3 | Rubber seal | 4 | Pressure spring |
| 5 | Connection to overflow bottle | 6 | Opening pressure of the radiator cap |
| 7 | Sealing surface | 8 | Tube connections |
| 9 | Sight glass | | |

General note

To equalize pressure in the cooling system, an expansion tank is required. If the pressure in the system rises above 1.2 bar (17.4 psi) as the coolant warms up, the pressure relief valve (1) opens and the coolant can flow into the overflow bottle via the line (5). When the coolant cools down, the return valve (2) opens and the coolant is sucked back.

Radiator cap

Inspect the rubber seal (3), the pressure spring (4) and the two valves incorporated in the radiator cap for damage and leaks. If necessary, replace with a new original radiator cap (6) with 1.2 bar (17.4 psi) opening pressure.

NOTE

The radiator cap must be tightened fully on the expansion tank until the stop lug is contacted.

Expansion tank

Inspect sealing surface (7) and tube connection (8) of the expansion tank. Carry out visual inspection of tank for damage and scuffing marks.

⚠ WARNING

Non-compliance can result in serious injuries or death!

FUEL SYSTEM

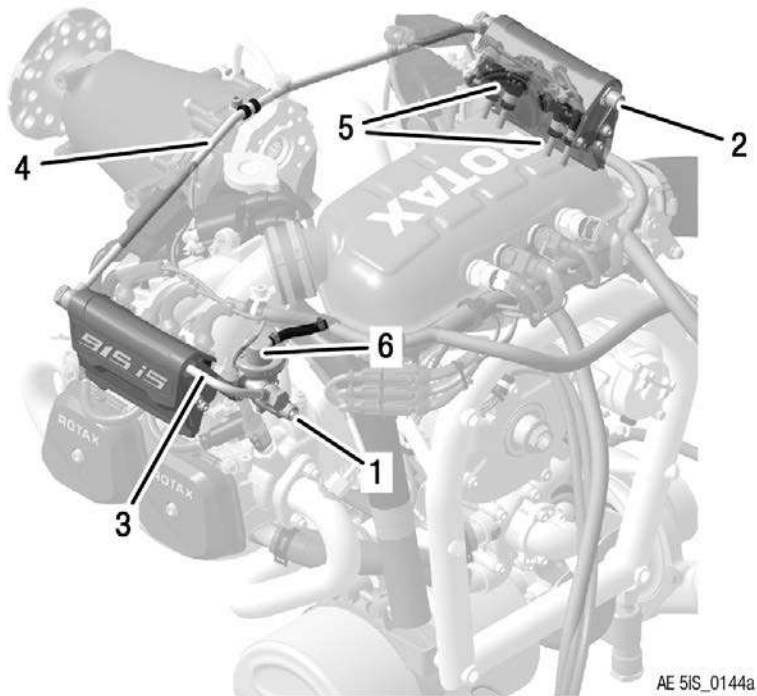

Figure 7.10: Overview, TYPICAL

- | | |
|------------------------|---------------------------------|
| 1 Fuel out/return line | 2 Fuel rail (1/3) and feed line |
| 3 Fuel rail (2/4) | 4 Fuel line assy. |
| 5 Fuel injector | 6 Fuel pressure regulator assy. |

BRP-Rotax
MAINTENANCE MANUAL LINE

LEAK TESTS

General note

NOTICE

Avoid over-tightening the fasteners. Use a suitable torque wrench for all work.

Instruction

To check the following steps are necessary:

Step	Procedure
1	Inspect all fuel lines (steel on engine), their connections and unions.
2	Inspect the fuel lines (steel on engine) for sign of chafing.

CHECKING THE FUEL LINES

General note

See [Chapter 05–10–00 section Time limit for parts](#).

Instruction

Step	Procedure
1	Check fuel line (of steel).

CHECKING THE FUEL PRESSURE REGULATOR

General note

Step	Procedure
1	Check the fuel pressure regulator (1) for damages and inspect the general condition.
2	Perform a leak test (Fuel pumps "ON").
3	Inspect all connections (2) for secure attachment.

BRP-Rotax
MAINTENANCE MANUAL LINE

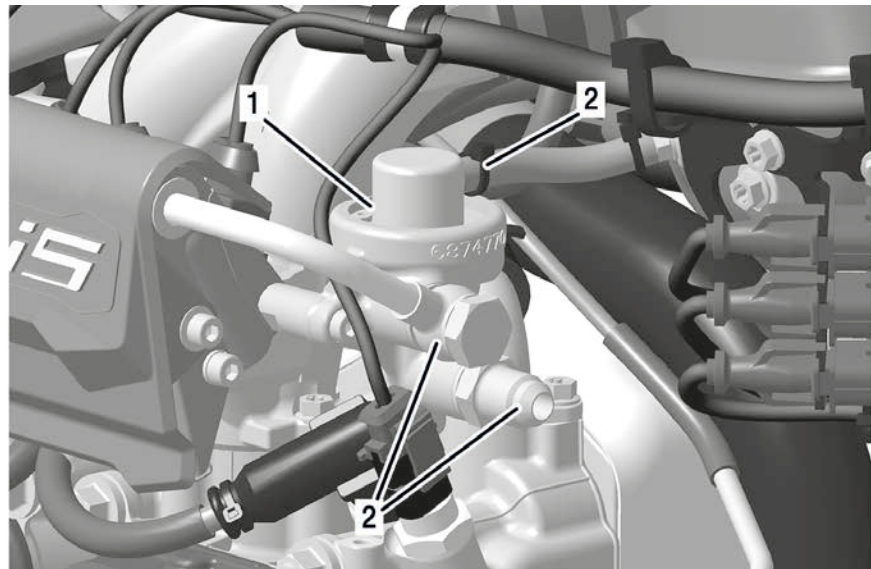

AE 5IS0080

Figure 7.11: Fuel pressure regulator

1 Fuel pressure regulator

2 Connection

FUEL INJECTORS

General note Check for leaks.

FUEL RAIL

General note Check for leaks.

BRP-Rotax
MAINTENANCE MANUAL LINE

LUBRICATION

Overview

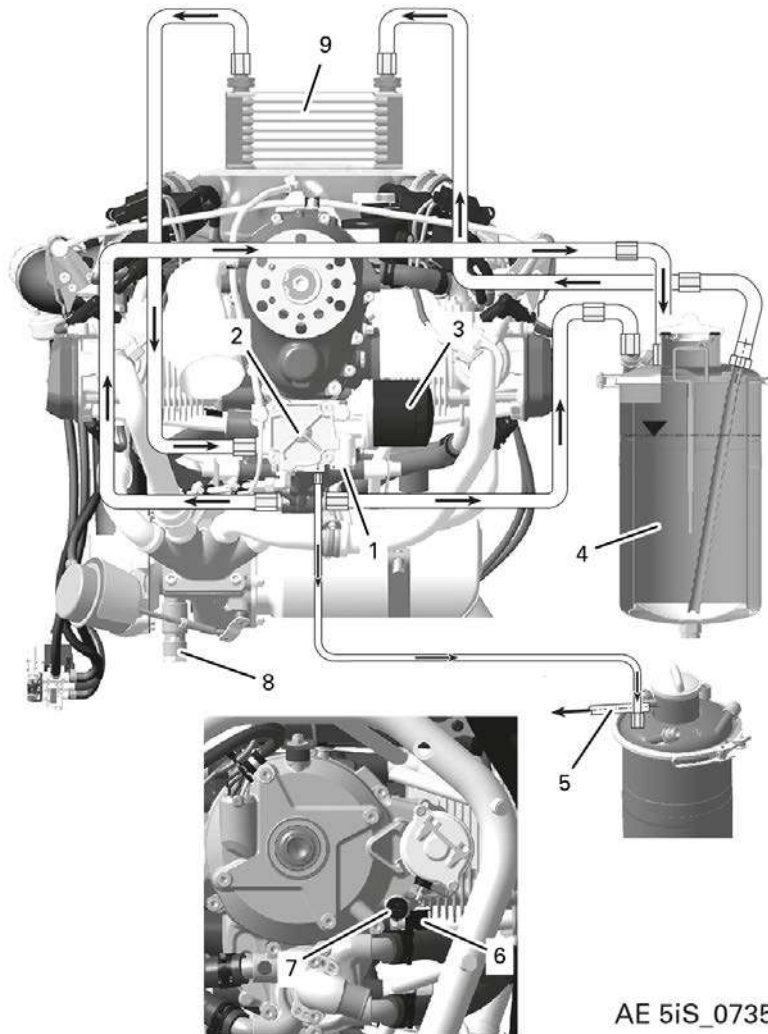

Figure 7.12

- | | |
|--------------------------|---|
| 1 Oil pressure regulator | 2 Oil pump |
| 3 Oil filter | 4 Oil tank |
| 5 Venting hose | 6 Oil temperature sensor |
| 7 Oil pressure sensor | 8 Plug screw assy. (oil sump, turbocharger) |
| 9 Oil radiator | |

BRP-Rotax
MAINTENANCE MANUAL LINE

General note

⚠ WARNING

Risk of burns and scalds. Hot engine parts.
Always allow engine to cool down to ambient temperature before starting work.

⚠ WARNING

Risk of electric shock!
Ignition "OFF" and system grounded! Disconnect negative terminal of battery.

NOTE

It is advisable to check the oil level prior to an oil change as it informs about oil consumption.

See [Chapter 12-10-00 section Oil level check/Replenish](#).

Observe

NOTICE

Observe the following to prevent possible unintentional voiding of the oil system and damage to the valve drive:

- Draining the suction lines, oil cooler and return line is not necessary and must be avoided, as it results in air entering the oil system.
See [Chapter 12-20-00 section Purging the oil system](#).
- Replacement of the oil filter and the oil change should be effected quickly and without interruption to prevent a draining of the oil system and the hydraulic tappets.

BRP-Rotax
MAINTENANCE MANUAL LINE

OIL CHANGE

Instruction

NOTE

Run engine to warm oil before beginning oil change procedure. To change the oil the following steps are necessary:

NOTICE

Use a 19 mm wrench to hold the hex nut of the oil tank when loosening or fastening the oil drain screw to avoid stress in the soldering.

Step	Procedure
1	Crank engine slowly by hand to transfer the oil from the crankcase. See Chapter 12-10-00 section Oil level check/Replenish .
2	Remove safety wire and oil drain screw from the oil tank, drain the used oil - see environment note.
3	Replace oil filter at each oil change, cut open and inspect the filter components. See Chapter 12-20-00 section Oil filter replacement and Inspection of the filter insert .
4	Dispose of oil filter according to environmental regulations.
5	Install oil drain screw with new gasket and safety wire (tightening torque 25 Nm (18 ft. lb)).

NOTICE

Only use brand name oil in accordance with the current Operators Manual (OM) and current SI-915 i-001 "Selection of suitable operation fluids".

NOTICE

The engine must not be cranked when the oil system is open. Attention must also be paid to this before first commissioning (e.g. when assembling the propeller after correct purging of the oil system).

NOTICE

DO NOT use compressed air to blow through the oil system (or oil lines, oil cooler, oil pump housing, oil bores in the engine).

ENVIRONMENTAL NOTE

Protect the environment.
Do not harm the environment by spilling oil. Dispose of oil in an environmentally friendly manner.

BRP-Rotax
MAINTENANCE MANUAL LINE

Step	Procedure
6	Install new oil filter. See New oil filter - installation .
7	Pour in approx. 3 l (0.8 gal (US)) of fresh oil.
8	After carrying out the oil change, the engine should be slowly cranked by hand in the direction of engine rotation (approx. 20 turns) to completely refill the entire oil circuit.

OIL FILTER - REMOVAL

General note

⚠ WARNING

Risk of burns and scalds. Hot engine parts.
Always allow engine to cool down to ambient temperature before starting work.

NOTICE

To ensure functioning of the oil circuit and the forced flow lubrication, use oil filter only. Only these filters will ensure correct pressure in the by-pass valve.

At every oil change, unscrew the oil filter and cut open using special tool taking care not to produce chips.

Special tools

To carry out the procedure the following tools are recommended:

part no.	Description
877620*	Oil filter wrench
276275*	Cutting tool
* or equivalent	

BRP-Rotax
MAINTENANCE MANUAL LINE

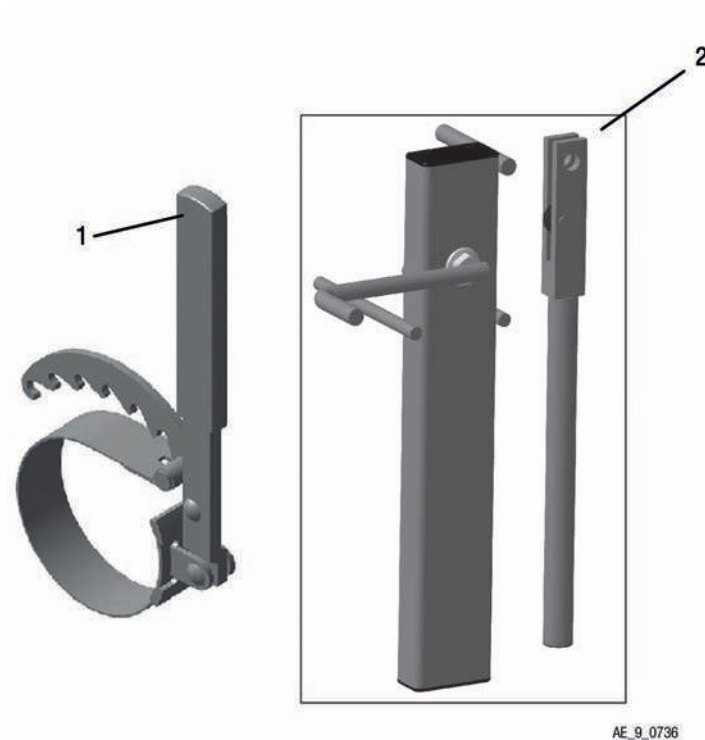

Figure 7.13: Special tool

1 Oil filter wrench part no. 877620*

2 Cutting tool part no. 276275*

**or equivalent*

Procedure

To remove the oil filter the following steps are necessary:

Step	Procedure
1	Remove used oil filter with oil filter wrench.
2	Clean the contact surface of the oil pump housing with a clean cloth.

BRP-Rotax
MAINTENANCE MANUAL LINE

INSPECTING OF THE OIL FILTER COMPONENTS

General note

NOTICE

The filter components must be inspected carefully.

This inspection is important as it allows conclusions to be drawn regarding the internal condition of the engine and provides information about the possible cause of any damage.

Procedure

To carry out the procedure the following steps are necessary:

Step	Procedure
1	Oil filter cut open using special tool taking care not to produce chips.
2	Remove anti-drain membrane.
3	Cut top and bottom edges off the mat with a knife.
4	Remove filter mat, fold up and press remaining oil out.
5	Unroll and inspect it for metal chips, foreign matter, contamination and abrasion.
6	Pass over matt with a clean magnet and inspect for metal.
7	Check oil filter housing for wear, especially on the contact surfaces.
8	Check springs of oil filter for wear.
9	Check sealing lip for wear, cracks and/or missing material.

Possible foreign matter

Steel chips	Bronze chips
Aluminium chips	Silver of bearing material
Remains of sealing compound	Plastic (thrust washer)
Carbon fiber	Silver or copper LOCTITE Anti Seize
Brass grit	

Increased foreign matter

If an increased amount of metal particles is found, such as brass- or bronze chips or silver from bearing abrasion, repair or overhaul the engine in accordance with the BRP-Rotax instructions for continued airworthiness. If the filter mat is clogged by foreign matter, oil reaches the bearing points unfiltered via the by-pass valve in the oil filter.

BRP-Rotax
MAINTENANCE MANUAL LINE

NOTE

Due to the technical construction of the ROTAX 915 i A / C24 gearbox – in particular the float-mounted torsion bar – wear on the brass oil inlet flange may occur. This has no impact on the engine's operational safety and is flushed through to the oil filter as designed. A larger amount of brass grit may initially occur at the first oil change interval, which gradually reduces to a minimum and eventually to zero wear. Nonetheless, when a higher amount of brass grit is found in the oil and oil filter the oil inlet flange shall be inspected in accordance with the current Maintenance Manual Heavy (MMH), Chapter 61–20–00, section GOVERNOR DRIVE CHECK to assure proper operation and functionality. The oil and oil filter shall be checked at the following 100 hours inspection in accordance with the current Maintenance Manual Line (MML). While more wear is visible in the first 25 hours, at 100 hours, despite the longer runtime, there shall only be the same amount or less in the oil. From a technical standpoint, there is nothing preventing the normal continued operation of the engine.

Unclear findings In the case of unclear findings:

Step	Procedure
1	Flush the oil circuit.
2	Fit a new oil filter.
3	Engine test run. See Chapter 12-20-00 section: Test run of engine.
4	Inspect the oil filter once more.

Contaminated

BRP-Rotax
MAINTENANCE MANUAL LINE

NOTICE

If the oil circuit is contaminated, replace the oil cooler and flush the oil circuit.
See Chapter 12-20-00 section: Flushing the oil circuit. Proper judgement re-quires years of experience in repair of piston engines.

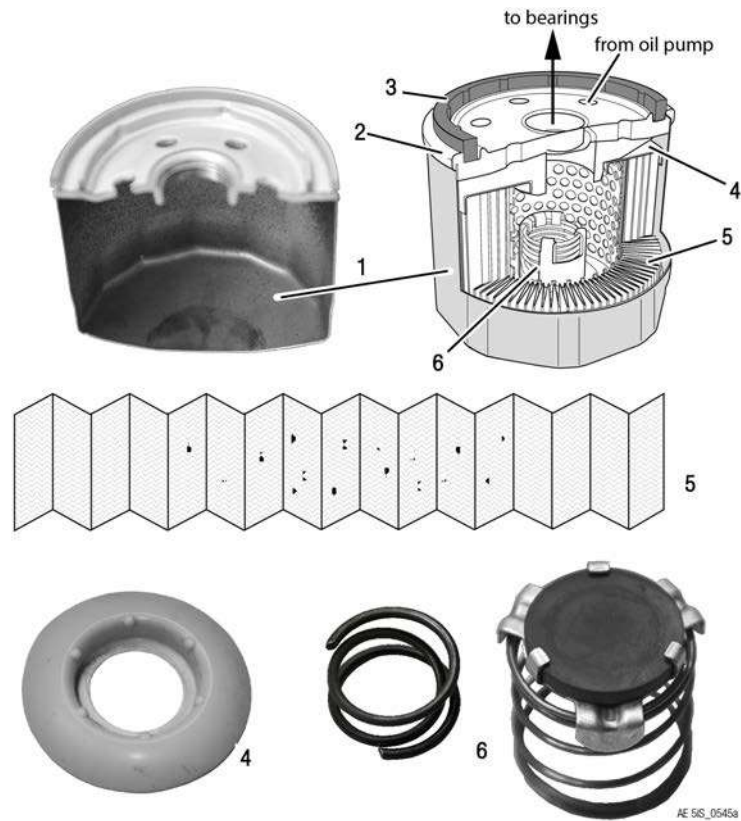

Figure 7.14: Oil filter

- 1 Filter housing
- 3 Gasket ring
- 5 Filter matt

- 2 Filter cover
- 4 Anti-drain membrane
- 6 Spring

BRP-Rotax
MAINTENANCE MANUAL LINE

NEW OIL FILTER - INSTALLATION

Procedure To mount the oil filter the following steps are necessary:

Step	Procedure
1	Clean the contact surface (1) of the oil pump housing (2) with a clean cloth.
2	Apply thin film engine oil on the gasket (3) of the oil filter (4).
3	Install the oil filter on the engine.
4	Screw on oil filter until oil filter gasket is seated solidly. NOTE <i>Mark 270° - check mark on oil pump housing to control tightening of oil filter.</i>
5	Tighten oil filter with 3/4 turn (270°).
6	Inspection of the used oil filter. See Chapter 12-20-00 section Inspection of the filter insert .

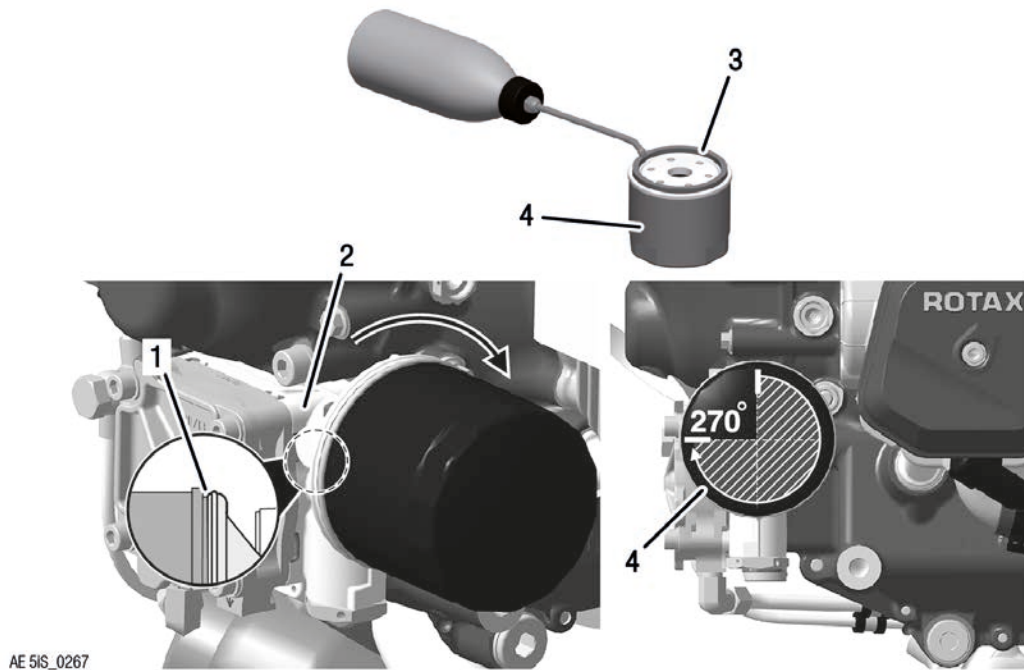

Figure 7.15: Install oil filter

- | | |
|-------------------|--------------------|
| 1 Contact surface | 2 Oil pump housing |
| 3 Gasket | 4 Oil filter |

BRP-Rotax
MAINTENANCE MANUAL LINE

CLEANING THE OIL TANK

General note

NOTE

For un-scheduled maintenance this procedure is optional. It is only necessary to clean the oil tank and the inner parts if there is heavy oil contamination. This procedure requires purging of the oil system, see [Chapter 12-20-00 section Purging the oil system](#). If using leaded fuel it is required to clean the tank according to the limits mentioned in [Chapter 05-20-00, section Scheduled maintenance checks](#).

Procedure

Procedure to clean the oil tank:

Step	Procedure
1	Detach the profile clamp and remove the oil tank cover together with the O-ring and the oil lines.
2	Remove safety wire.
3	Remove the inner parts of the oil tank such as the baffle insert and the partition.
4	Clean oil tank and inner parts and check for damage.

NOTICE

Incorrect assembly of the oil tank components might cause engine faults or engine damage.

Step	Procedure
5	Fit hex. double ignition screw M12x12 with a new gasket ring. Tightening torque 25 Nm (18 ft.lb).
6	Re-install safety wire.
7	Reassemble the oil tank by following the same steps in reverse order.
8	Purge the oil system.

BRP-Rotax
MAINTENANCE MANUAL LINE

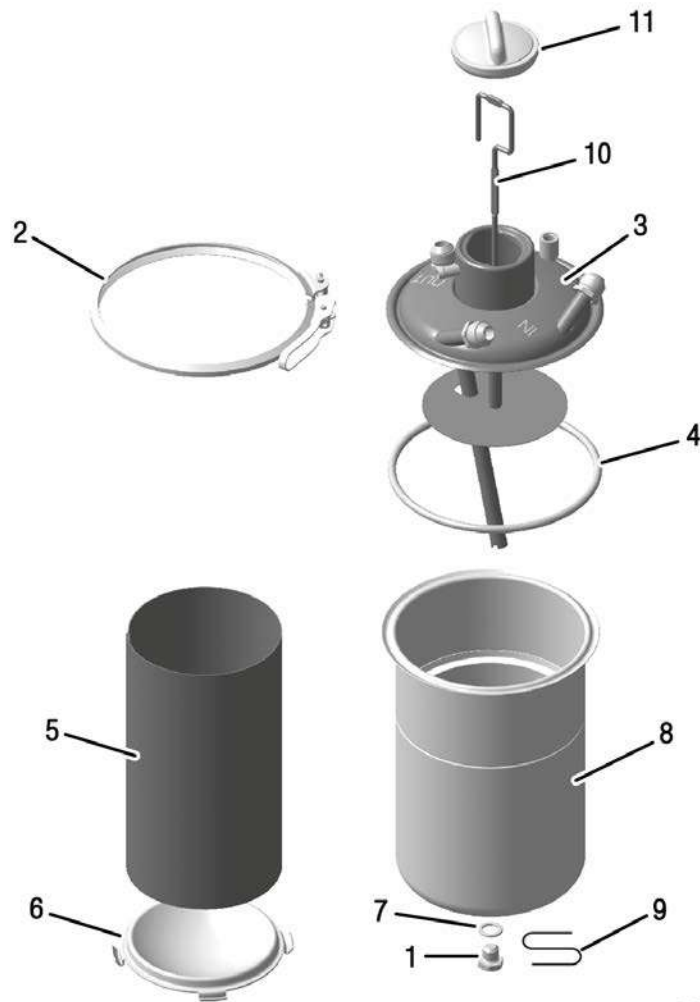

AE 5iS_0083

Figure 7.16: Oil tank

- | | | | |
|----|---------------------------------|----|------------------|
| 1 | Hex. screw M12x12 | 2 | Profile clamp |
| 3 | Oil tank cover assy. Metric/UNF | 4 | O-ring |
| 5 | Baffle insert | 6 | Partition/screen |
| 7 | Gasket ring 12x18 | 8 | Oil tank |
| 9 | Safety wire | 10 | Dipstick |
| 11 | Oil tank cover | | |

BRP-Rotax
MAINTENANCE MANUAL LINE

PURGING THE OIL SYSTEM

General note

NOTICE

Purging of the oil system is extremely important for operation and service life of the engine and therefore the procedure must be followed meticulously.



See current Installation Manual (IM) for the respective engine type, Chapter 79-00-00 section Purging the lubrication system.

Purging the oil system

Purging the oil system is necessary:

- with initial installation of new engine
- after reinstallation (e.g. after overhaul)
- after maintenance work during which the lubrication system was opened and voided (e.g. removal of the oil tank or oil cooler, replacement of oil lines).

FLUSHING THE OIL CIRCUIT

General note

⚠ WARNING

Risk of electric shock!

Ignition "OFF" and system grounded! Disconnect negative terminal of battery.

Oil tank

Clean the oil tank.

Oil lines

Dismantle and flush oil lines as per instructions of the aircraft manufacturer.

Temporary oil lines

Temporary oil lines (only for flushing) must be fitted so that the oil radiator is not connected. The return line is routed into a separate, clean receptacle and not back to the oil tank.

NOTE

This is done to prevent metal chips and other debris from entering the radiator or oil tank.

Filling

Fill the oil tank with approx. 3 l (0.8 gal (US)) of engine oil.

Procedure

The following steps have to be carried out after refilling:

BRP-Rotax
MAINTENANCE MANUAL LINE

NOTICE

The oil level in the tank must not drop below the end of suction pipe, otherwise air will be sucked in again.

Step	Procedure
1	Turn engine by hand in direction of engine rotation to return the oil from the oil tank into the engine and into the collection container. The procedure is complete when no more contamination can be discovered.
2	Control the oil captured during the rinsing process. The rinsing process is complete when no more contamination can be discovered.
3	Re-install cleaned oil lines and oil cooler according to the manufacturers instruction.
4	Install new oil filter and refill with oil.
5	Purge oil system.

Reconnect negative terminal of aircraft battery.
See [Chapter 12-20-00 section Purging of the oil system](#).

Equipment

NOTICE

Equipment is to be inspected in accordance with the Maintenance Manual of the aircraft manufacturer.

INSPECTING THE MAGNETIC PLUG

General note

NOTE

The magnetic plug is located on the crankcase between cylinder 2 and gearbox.

This inspection is important because it allows conclusions to be drawn on the internal condition of the gearbox and engine and reveals information about possible damage.

Procedure

Remove the magnetic plug and inspect it for accumulation of chips.

Steel chips in low numbers

Steel chips in low numbers as depicted in [Fig. Overview](#) can be tolerated if the accumulation is below 3 mm (0.125 in).

Steel chips in larger numbers

If there are larger accumulations of metal chips on the magnetic plug, the engine must be repaired/overhauled according to the BRP-Rotax instructions for continued airworthiness.

Unclear findings

In the case of unclear findings:

Step	Procedure
1	Rinse magnet in solvent and check again (the contamination may be only from engine assy. lubricants e.g. molybdenum grease)
2	Flush the oil circuit.
3	Fit a new oil filter.
4	Install the magnetic plug. See Chapter 12-20-00 section Installation of the magnetic plug.
5	Engine test run. See Chapter 12-20-00 section Test run of engine.
6	Inspect the magnetic plug once more.

Contamination

NOTICE

**If the oil circuit is contaminated, replace the oil cooler and flush the oil circuit.
Proper judgement requires years of experience in repair of piston engines.**

Trace the cause and remedy.

BRP-Rotax
MAINTENANCE MANUAL LINE

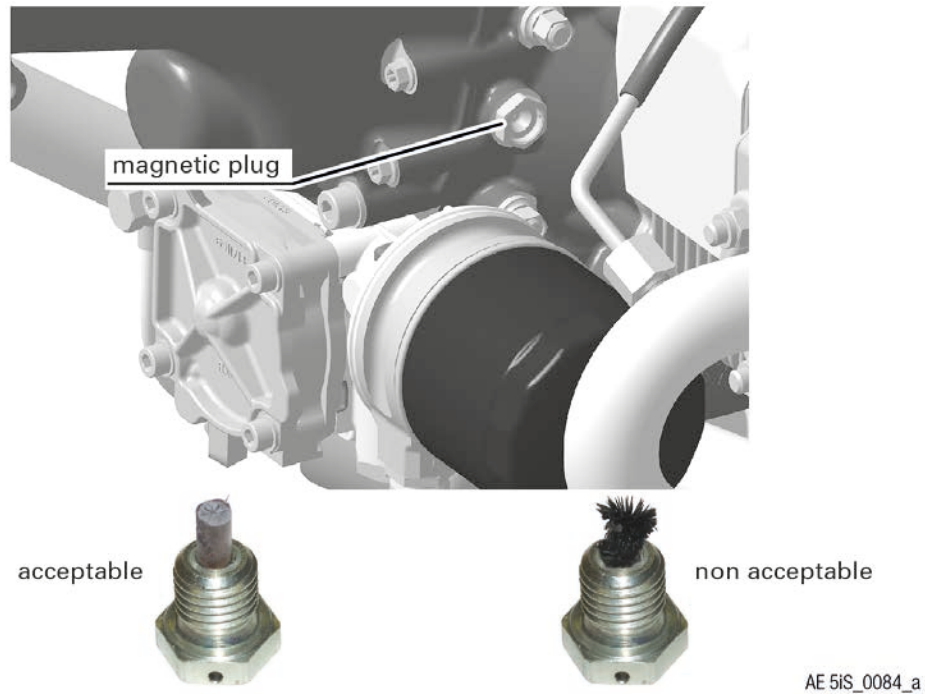

Figure 7.17: Overview TYPICAL

INSTALLATION OF THE MAGNETIC PLUG

Install

The following steps are necessary:

Step	Procedure
1	Clean the magnetic plug.
2	Install the magnetic plug. Tightening torque 25 Nm (18 ft lb.)
3	Secure with safety wire.

Inspect all systems for correct function. Detailed inspection of affected engine components.

ELECTRIC SYSTEM

915 i TYPE A

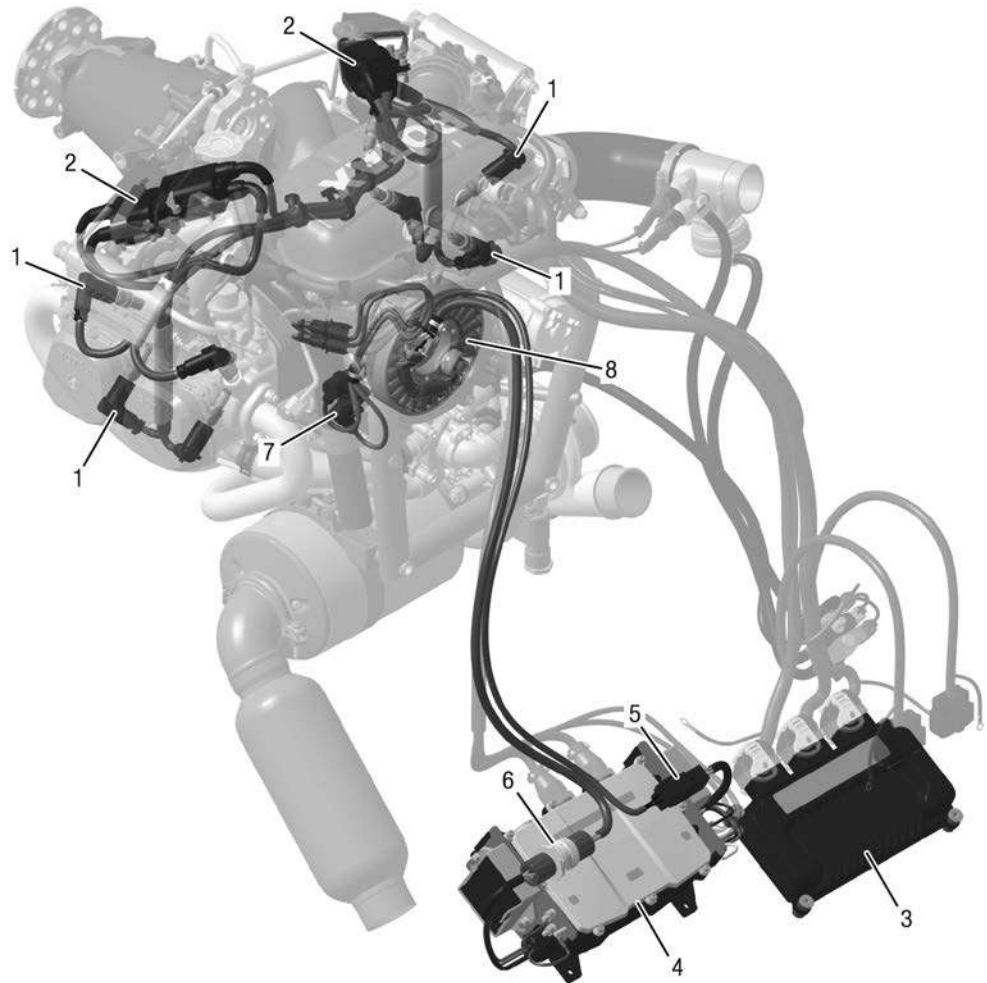

AE 6iS_0247

Figure 7.18: Overview, TYPICAL

- | | |
|--|-------------------------|
| 1 Spark plug connectors | 2 Double ignition coil |
| 3 Engine Control Unit (ECU) | 4 FUSE BOX assy. |
| 5 Connector Generator A | 6 Connector Generator B |
| 7 Crankshaft Position Sensor (CPS 1/2) | 8 Generator A and B |

BRP-Rotax
MAINTENANCE MANUAL LINE

915 i TYPE C 24

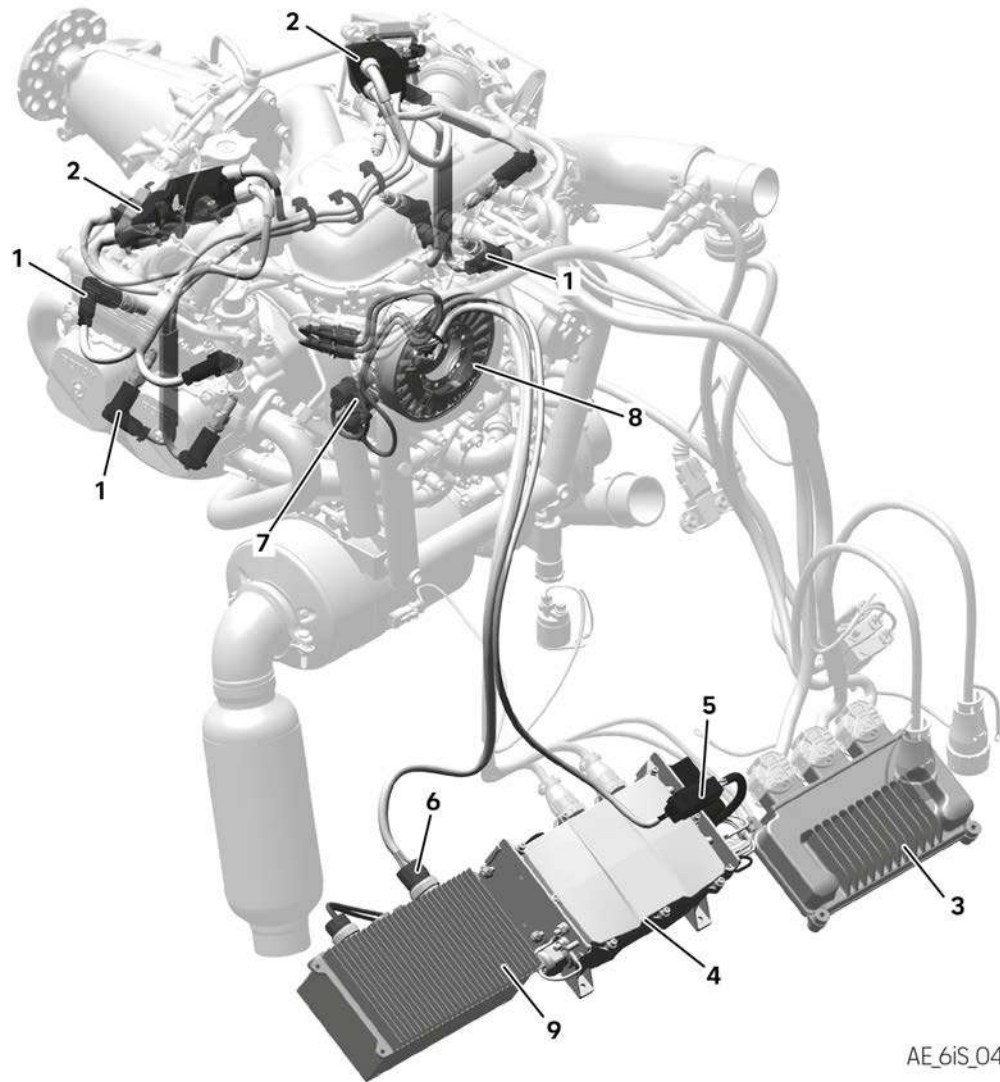

AE_6iS_0442

Figure 7.19: Overview, TYPICAL

- | | |
|--|-------------------------|
| 1 Spark plug connectors | 2 Double ignition coil |
| 3 Engine Control Unit (ECU) | 4 FUSE BOX assy. |
| 5 Connector Generator A | 6 Connector Generator B |
| 7 Crankshaft Position Sensor (CPS 1/2) | 8 Generator A and B |
| 9 24 V Connector | |

BRP-Rotax
MAINTENANCE MANUAL LINE

CHECK OF WIRING

General note

⚠ WARNING

Risk of electric shock!

Ignition "OFF" and system grounded! Disconnect negative terminal of battery.

⚠ WARNING

Risk of burns and scalds. Hot engine parts.

Always allow engine to cool down to ambient temperature before starting work.

Procedure

The following steps have to be carried out:

Step	Procedure
1	Inspect all cable connectors and their connections for tight fit, good contact, corrosion or damage and replace as necessary.
2	Inspect all ground connections for corrosion and damage, replace if necessary.
3	Inspect plug connections of ignition coils for corrosion or damage and replace if necessary.
4	Verify plug connections on generator cables with rectifier-regulator and connections of all cables on regulators for good contact, tight fit, corrosion, discoloration or damage and replace if necessary.
5	Inspect grounding cables for tight fit, corrosion or damage and replace if necessary.
6	Verify shielding of cable assemblies for corrosion or damage, good ground contact and tight fit, inspect the attachment of the shielding and replace if necessary.
7	Inspect all 8 ignition cables to spark plug connector for corrosion or damage and tight fit and replace if necessary.
8	Fuse unit: Check fuse plugs/relays and replace if necessary.
9	ECU: Check the condition of the connectors or if any pins are bent or pushed in.

BRP-Rotax
MAINTENANCE MANUAL LINE

REPLACEMENT OF SPARK PLUGS

General note

NOTICE

Use of incorrect spark plugs can result in ignition problems and pre-ignition and consequent engine damage.

In numerous tests the best possible heat range has been determined to make sure that the spark plug will burn off deposits but will not overheat.

Renewal intervals **NOTE**

Operation with leaded fuels (e.g. AVGAS 100LL) can result in increased wear of the spark plugs. Reduce renewal intervals accordingly.

Spark plugs



See current Illustrated Parts Catalog (IPC) for the respective engine type.

REMOVE THE SPARK PLUGS

Remove Remove the spark plugs and store them according to cylinder and position.

INSPECTION OF SPARK PLUGS

Visual check Inspect all spark plugs for mechanical damage.

Electrode gap **NOTE**

Check the electrode gap also on new spark plugs before installation.

NOTE

Due to a curved gap between the center electrode and the ground electrodes, it is suggested to use a wire type feeler gauge for accurate gap measurement.

NOTICE

Adjustment of the spark plug gap is not allowed. If gap measurement is over permissible limit, the spark plug must be replaced

Electrode gap	
New	Wear limit
0.8 - 0.9 mm (0.031 - 0.035 in)	1.1 mm (0.043 in)

BRP-Rotax MAINTENANCE MANUAL LINE

Spark plug face Spark plug face reveals the following about the operating condition of the engine:

Spark plug face	Information
light tan- colored	plug and calibration of the engine are correct
velvet black	Possibly indicates one or more of the following: <ul style="list-style-type: none">• mixture too rich• insufficient air intake (clogged air filter)• engine operating temperature too low
oily, glossy coating	Possibly indicates one or more of the following: <ul style="list-style-type: none">• damaged valve stem seal• misfiring• too much oil in combustion chamber• worn cylinder and piston rings
white with formation of melt beads	Possibly indicates one or more of the following: <ul style="list-style-type: none">• mixture too lean• leaking valves

BRP-Rotax
MAINTENANCE MANUAL LINE

INSTALLATION OF SPARK PLUG

I Overview

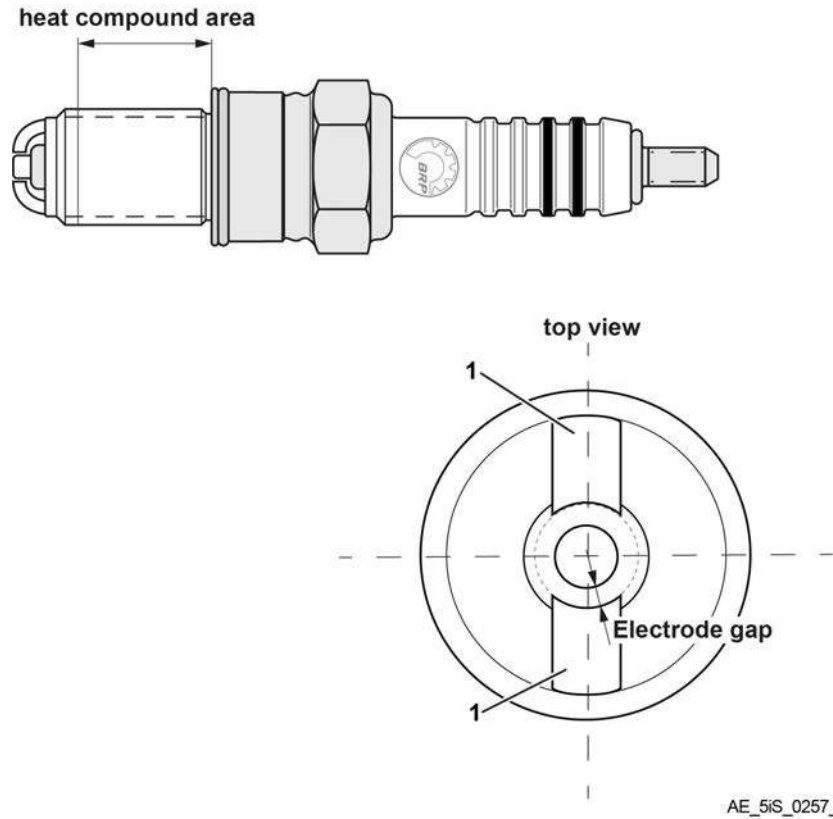

Figure 7.20: Spark plugs

1 Ground electrode

Cleaning

⚠ WARNING	
Eyes and skin irritation!	
Rinse off with water in the case of contact with eyes or skin. May be harmful if swallowed.	

Step	Procedure
1	Before every installation, the spark plug thread and the spark plug seat at the cylinder head should be cleaned (e.g. to remove residue of silicone heat compound).

BRP-Rotax
MAINTENANCE MANUAL LINE

Installation

NOTICE	
Always replace both spark plugs of a cylinder and do not interchange spark plugs between cylinders.	

NOTICE	
Silicone heat compound at the ground electrode or the head area can lead to ignition problems. Apply heat compound sparingly and do not apply to the first three threads.	

Step	Procedure
2	Apply small amount of silicone heat compound to spark plug thread and tighten spark plug to 16 Nm (142 in. lb) on the cold engine.

FUSE BOX

General note

Check plug connections and fuse plugs (fuses). Check LED indicators.

BRP-Rotax
MAINTENANCE MANUAL LINE

TURBOCHARGER

Checking the waste gate lever

Step	Procedure
1	Check the waste gate lever for free movement. If it does not move freely, lubricate the axle of the waste gate with LOCTITE ANTI SEIZE 15378.

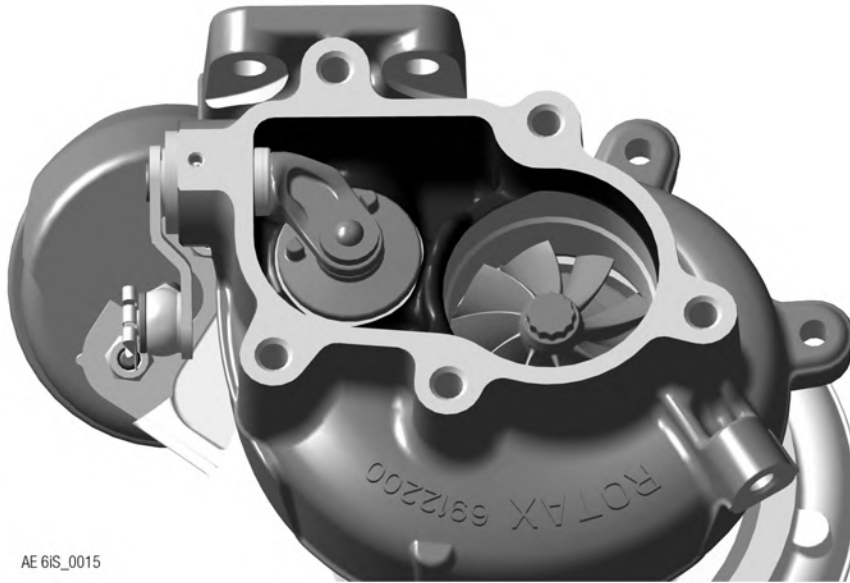

AE 6IS_0015

Figure 7.21

CHECKING AND CLEANING PLUG SCREW (TURBO OIL SUMP ASSY.)

Procedure

To check and clean the following steps are necessary:
 See Figure [Oil sump assy.](#)

Step	Procedure
1	Loosen the plug screw assy. M22x1.5 (1) with the O-ring 18x2.5 (2).
2	Drain the residual oil from the oil sump assy.
3	Inspect the plug screw assy. of metal particals.
4	Clean the plug screw with suitable clean agent.
5	Install plug screw assy. M22x1.5 with O-ring 18x2.5 into the oil sump assy..
6	Tightening torque 20 Nm (15 ft. lb).
7	Lockwire plug screw assy.

BRP-Rotax
MAINTENANCE MANUAL LINE

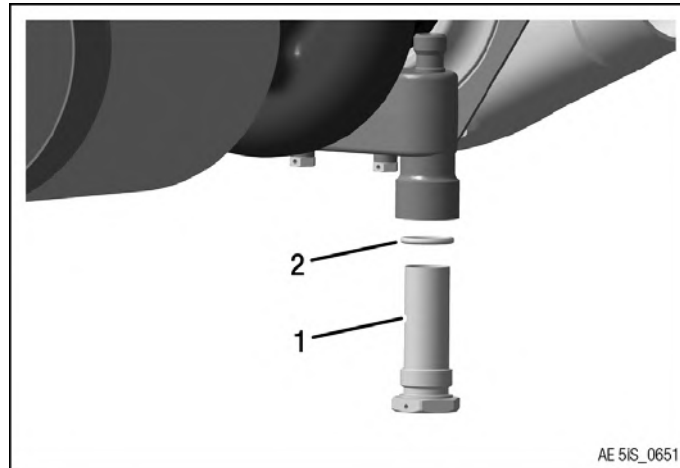
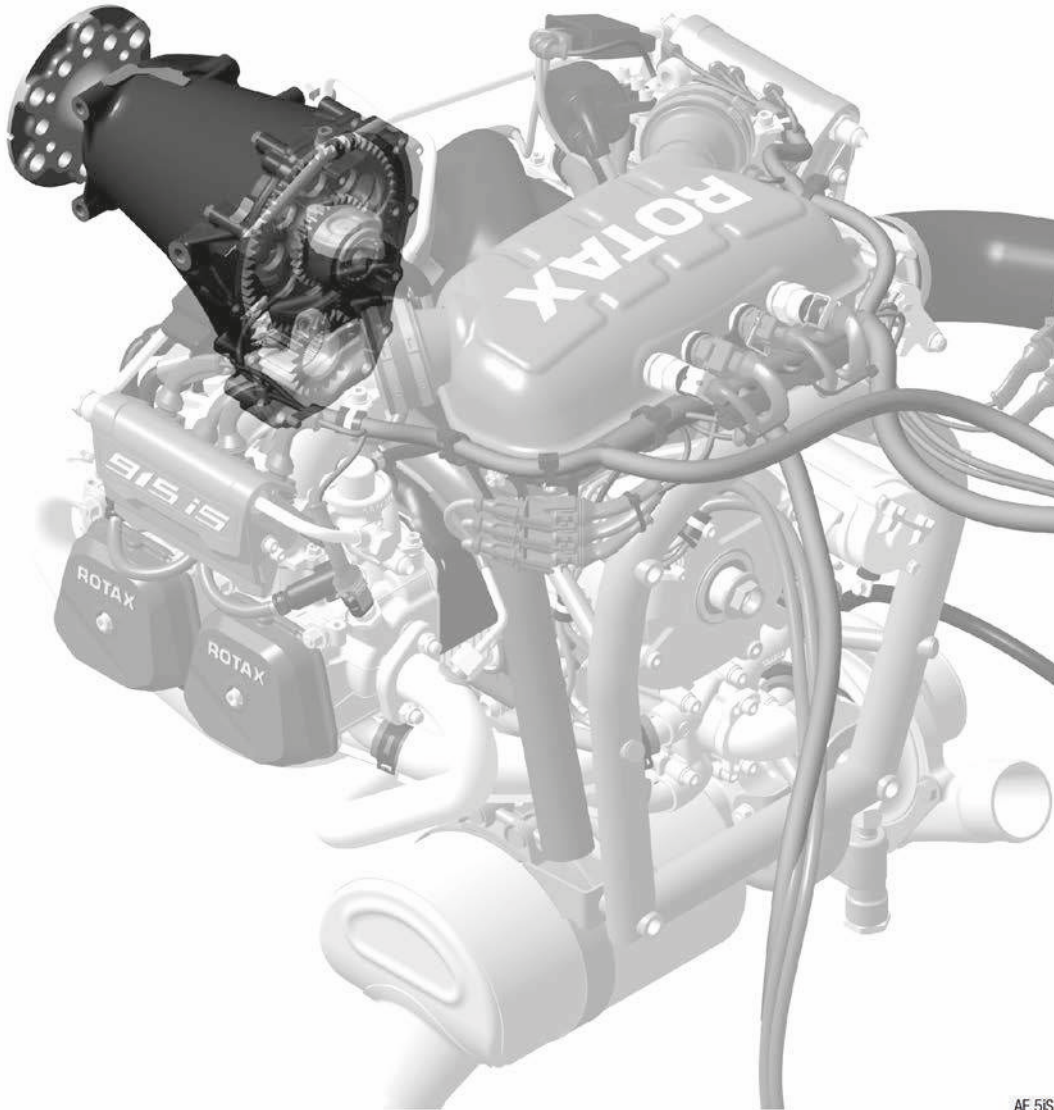

Figure 7.22: Oil sump assy.

1 Plug screw assy. M22x1.5

2 O-ring 18x2.5

PROPELLER GEARBOX



AE 5iS_0156

Figure 7.23: Overview

CHECKING THE PROPELLER GEARBOX

General note



For checking of the propeller gearbox see current Maintenance Manual Heavy (MMH) for the respective engine type.

BRP-Rotax
MAINTENANCE MANUAL LINE

CHECK POP-OFF VALVE

NOTE

This functional check is to be performed on an assembled pop-off valve assembly.



See current Maintenance Manual Heavy (MMH) for the respective engine type, Chapter 73-10-00 for removal, disassembly, inspection and assembly / installation of the pop-off valve assy.

Step	Procedure
1	Loosen the 1-ear clamp and remove the control hose (2).
2	Connect a vacuum pump to the pop-off valve hose nipple (3).
3	Apply a vacuum of 700 mbar (10.15 psi).

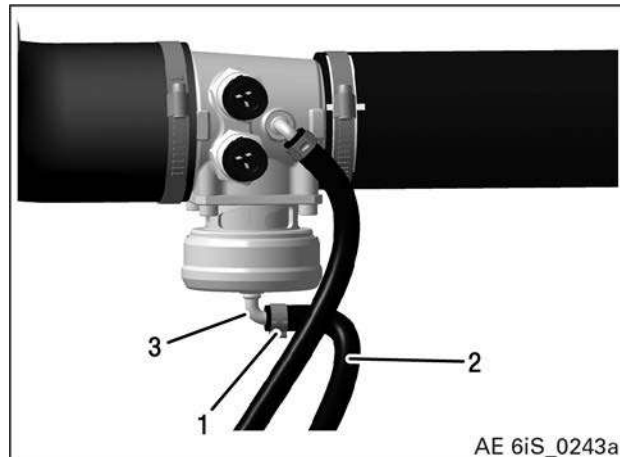

Figure 7.24: Oil tank

1 1-ear clamp

2 Control hose

3 Hose nipple

Step	Procedure
4	The piston must move smoothly and be fully open at 700 mbar (10.15 psi).
5	Release the vacuum, the piston will be returned to fully closed by internal spring force.

BRP-Rotax
MAINTENANCE MANUAL LINE

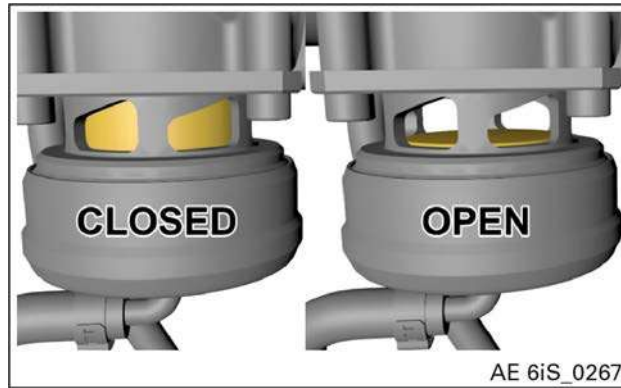

Figure 7.25: Oil tank

Step	Procedure
6	Remove vacuum tool and temporary lines and clamps.
7	Attach control hose 600 mm (23.6 in.) (2) with new 1-ear clamp 10.3 - 12.8 mm (1) on hose nipple (3) of the pop-off valve.

NOTICE

If the pop-off valve piston does not smoothly operate from fully closed position (resting) to fully open position (under vacuum) or at an excessive vacuum leak, the complete pop-off valve assembly must be inspected and any malfunction corrected.

NOTICE

An improperly functioning pop-off valve can adversely affect engine performance.

BRP-Rotax
MAINTENANCE MANUAL LINE

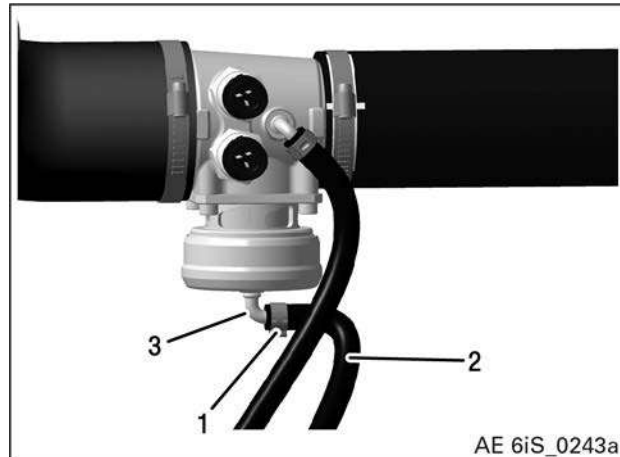

Figure 7.26: Oil tank

1 1-ear clamp 10.3-12.8 mm

2 Control hose 600 mm (23.6 inch.)

3 Hose nipple

BRP-Rotax
MAINTENANCE MANUAL LINE

Index

A

Abbreviations	3
Acceptable methods, techniques and practice	12
Airworthiness Limitations	1
Annual inspection	7
Authorized personnel	4

C

Check List/Maintenance Schedule	6
Check of wiring	45
Check POP-OFF VALVE	54
Checking and cleaning plug screw (turbo oil sump assy.)	50
Checking ECU	13
Checking of the Cooling system / radiator cap	27
Checking the AC-DC Converter warning lamps	14
Checking the cooling system	20
Checking the engine suspension	4
Checking the fuel line pressure	26
Checking the fuel lines	26
Checking the propeller gearbox	52
Cleaning the oil tank	37
Consumable Materials	8
Conversion table	9
Coolant check/replenish	4
Cooling system	4, 19
Corrosion	5

D

Definition of terms	2
Differential and crankcase pressure check	8
Drive gear – Removal	6

E

Electric system	43
EMS	21
Engine check after propeller strike incidents	2
Engine cleaning	3
Engine control unit (ECU)	13
Engine submerging in water	20

Examination after engine failure	19
Exceeding of max. admissible engine RPM	22
Exceeding of max. coolant temperature	24
Exceeding the max. permissible oil temperature	33
Expansion tank	24
Extreme climatic conditions	21

F

Fluid capacities	3
Flushing the cooling system	23
Flushing the oil circuit	39
Fuel injection	27
Fuel rail	27
Fuel system	25
Fuse box	49

G

General	2
General overhaul, TBO	3

I

Influence by fire	22
Inspecting of the oil filter components	33
Inspecting the magnetic plug	41
Inspection of spark plugs	46
Installation of propeller gearbox	13
Installation of spark plug	48
Installation of the magnetic plug	42
Instruction	13

L

Leak tests	26
Leakage check	6
Life cycle	3
Lightning strike	44
List of effective pages	1
Lock/Loosen the crankshaft	15
Lubrication	28
Lubrication system	7

BRP-Rotax
MAINTENANCE MANUAL LINE

M

Maintenance Concept14
Maintenance Schedule8
Maintenance schedule procedures5

N

New oil filter - installation36
Non compliance — coolant specification26
Non compliance — fuel quality39

O

Oil change30
Oil filter removal31
Oil level check/Replenish7
Oil pressure below minimum value34
Oil specification not respected37
Operating hours2

P

Periodic rise and fall in boost pressure and
speed44
Procedure notes5
Propeller gearbox52
Propeller Strike Inspection7
Purging the oil system 3, 39

R

Radiator cap24
Read out the ECU data memory14
Removal of the propeller gearbox2
Remove the spark plugs46
Replacement of spark plugs46
Replacing the coolant21
Replenishing operating fluids1
Reporting45

S

Safety10
Safety information11
Scheduled maintenance2
Scheduled maintenance checks1–2
Servicing points on the engine2
Smooth performance of the engine40
Spark plug not in accordance with speci-
fication39
Sudden drop in boost pressure and speed42
Sudden increase in boost pressure and speed ..43

T

Table of amendments1
Technical documentation15
Terminology2
Terms3
Test run of engine17
Time limit3
Time Limit4
Time limit for the coolant7
Time limit, parts6
Time limits1
Troubleshooting7
Turbocharger50

U

Unscheduled maintenance checks 3, 1
Use for intended purpose17

V

Visual inspection4

W

Wiring color codes8

ROTAX®

Engine serial no.

Type of aircraft

Aircraft registration no.

Rotax® authorized distributor

FLYROTAX.COM

® and TM are trademarks of BRP-Rotax GmbH & Co KG.

© 2025 BRP-Rotax GmbH & Co KG. All rights reserved.

