

ROTAX[®]

MAINTENANCE MANUAL LINE

FOR ROTAX ENGINE TYPES 914 SERIES

REF NO.: MML-914 | PART NO.: 899193



WARNING

Before starting any maintenance work, please read the Maintenance Manual completely as it contains important safety relevant information. Failure to do so may result in personal injuries including death. Consult the original equipment manufacturers handbook for additional instructions!

These technical data and the information embodied therein are the property of BRP-Rotax GmbH & CO KG, Austria, acc, BGBl 1984 no. 448, and shall not, without prior written permission of BRP-Rotax GmbH & Co KG, be disclosed in whole or in part to third parties. This legend shall be included on any reproduction of these data, in whole or in part. The Manual must remain with the engine/aircraft in case of sale.

ROTAX® is a trade mark of BRP-Rotax GmbH & Co KG. In the following document the short form of BRP-Rotax GmbH & Co KG = BRP-Rotax is used.

Other product names in this documentation are used purely for ease of identification and may be trademarks of the respective company or owner.

Copyright 2024 © - all rights reserved.

Translation into other languages might be performed in the course of language localization but does not lie within ROTAX® scope of responsibility.

In any case the original text in English language and the metric units are authoritative.

BRP-Rotax
MAINTENANCE MANUAL LINE

Table of Content

Chapter	INTRO – GENERAL NOTE
Chapter	LEP – LIST OF EFFECTIVE PAGES
Chapter	TOA – TABLE OF AMENDMENTS
Chapter	00-00-00 – GENERAL NOTE
Chapter	04-00-00 – AIRWORTHINESS LIMITATIONS
Chapter	05-00-00 – MAINTENANCE
Chapter	05-10-00 – TIME LIMITS
Chapter	05-20-00 – SCHEDULED MAINTENANCE CHECKS
Chapter	05-50-00 – UNSCHEDULED MAINTENANCE CHECKS
Chapter	12-00-00 – MAINTENANCE OF THE SYSTEMS
Chapter	12-10-00 – REPLENISHING OPERATING FLUIDS
Chapter	12-20-00 – SCHEDULED MAINTENANCE

BRP-Rotax
MAINTENANCE MANUAL LINE

INTENTIONALLY LEFT
BLANK

BRP-Rotax
MAINTENANCE MANUAL LINE

Chapter: INTRO
GENERAL NOTE

Foreword

Before carrying out maintenance work on the engine, read this Maintenance Manual carefully.

If any passages of the Manual are not clearly understood or in case of any questions, please contact your nearest ROTAX® Authorized Aircraft Engines Distributors or their independent Service Centers.

BRP-Rotax wishes you much pleasure and satisfaction flying your aircraft powered by this ROTAX®-aircraft engine.

The structure of the Manual follows whenever it is possible the structure of the ATA (Air Transport Association) standards. The aim is the compatibility with the aircraft manufacturers documentation, which means they must then adapt the documentation to their standard.

BRP-Rotax
MAINTENANCE MANUAL LINE

INTENTIONALLY LEFT
BLANK

**BRP-Rotax
MAINTENANCE MANUAL LINE**

**Chapter: LEP
LIST OF EFFECTIVE PAGES**

Each new revision to the Maintenance Manual Line will have a new List of Effective Pages.

Chapter	Page	Date
	Cover page	
INTRO	1	March 01 2024
	2	March 01 2024
LEP	1	March 01 2024
	2	March 01 2024
	3	March 01 2024
	4	March 01 2024
TOA	1	March 01 2024
	2	March 01 2024
00-00-00	1	March 01 2024
	2	March 01 2024
	3	March 01 2024
	4	March 01 2024
	5	March 01 2024
	6	March 01 2024
	7	March 01 2024
	8	March 01 2024
	9	March 01 2024
	10	March 01 2024
	11	March 01 2024
	12	March 01 2024
	13	March 01 2024
	14	March 01 2024
	15	March 01 2024
	16	March 01 2024
	17	March 01 2024
	18	March 01 2024
04-00-00	1	March 01 2024

Chapter	Page	Date
	2	March 01 2024
05-00-00	1	March 01 2024
	2	March 01 2024
	3	March 01 2024
	4	March 01 2024
	5	March 01 2024
	6	March 01 2024
	7	March 01 2024
	8	March 01 2024
	9	March 01 2024
	10	March 01 2024
	11	March 01 2024
	12	March 01 2024
	13	March 01 2024
	14	March 01 2024
05-10-00	1	March 01 2024
	2	March 01 2024
	3	March 01 2024
	4	March 01 2024
	5	March 01 2024
	6	March 01 2024
05-20-00	1	March 01 2024
	2	March 01 2024
	3	March 01 2024
	4	March 01 2024
	5	March 01 2024
	6	March 01 2024
	7	March 01 2024
	8	March 01 2024

BRP-Rotax
MAINTENANCE MANUAL LINE

Chapter	Page	Date	Chapter	Page	Date
05-50-00	9	March 01 2024		26	March 01 2024
	10	March 01 2024		27	March 01 2024
	11	March 01 2024		28	March 01 2024
	12	March 01 2024		29	March 01 2024
	13	March 01 2024		30	March 01 2024
	14	March 01 2024		31	March 01 2024
	15	March 01 2024		32	March 01 2024
	16	March 01 2024		33	March 01 2024
	1	March 01 2024		34	March 01 2024
	2	March 01 2024		35	March 01 2024
	3	March 01 2024		36	March 01 2024
	4	March 01 2024		37	March 01 2024
	5	March 01 2024		38	March 01 2024
	6	March 01 2024		39	March 01 2024
	7	March 01 2024		40	March 01 2024
	8	March 01 2024		41	March 01 2024
	9	March 01 2024		42	March 01 2024
	10	March 01 2024		43	March 01 2024
	11	March 01 2024		44	March 01 2024
	12	March 01 2024		45	March 01 2024
	13	March 01 2024		46	March 01 2024
	14	March 01 2024		47	March 01 2024
	15	March 01 2024		48	March 01 2024
	16	March 01 2024		49	March 01 2024
	17	March 01 2024		50	March 01 2024
18	March 01 2024		51	March 01 2024	
19	March 01 2024		52	March 01 2024	
20	March 01 2024		53	March 01 2024	
21	March 01 2024		54	March 01 2024	
22	March 01 2024		55	March 01 2024	
23	March 01 2024		56	March 01 2024	
24	March 01 2024		12-00-00	1	March 01 2024
25	March 01 2024			2	March 01 2024

BRP-Rotax
MAINTENANCE MANUAL LINE

Chapter	Page	Date
12-10-00	1	March 01 2024
	2	March 01 2024
	3	March 01 2024
	4	March 01 2024
	5	March 01 2024
	6	March 01 2024
	7	March 01 2024
	8	March 01 2024
12-20-00	1	March 01 2024
	2	March 01 2024
	3	March 01 2024
	4	March 01 2024
	5	March 01 2024
	6	March 01 2024
	7	March 01 2024
	8	March 01 2024
	9	March 01 2024
	10	March 01 2024
	11	March 01 2024
	12	March 01 2024
	13	March 01 2024
	14	March 01 2024
	15	March 01 2024
	16	March 01 2024
	17	March 01 2024
18	March 01 2024	
19	March 01 2024	
20	March 01 2024	
21	March 01 2024	
22	March 01 2024	
23	March 01 2024	
24	March 01 2024	
25	March 01 2024	

Chapter	Page	Date
	26	March 01 2024
	27	March 01 2024
	28	March 01 2024
	29	March 01 2024
	30	March 01 2024
	31	March 01 2024
	32	March 01 2024
	33	March 01 2024
	34	March 01 2024
	35	March 01 2024
	36	March 01 2024
	37	March 01 2024
	38	March 01 2024
	39	March 01 2024
	40	March 01 2024
	41	March 01 2024
	42	March 01 2024
	43	March 01 2024
	44	March 01 2024
	45	March 01 2024
	46	March 01 2024
	47	March 01 2024
	48	March 01 2024
	49	March 01 2024
	50	March 01 2024
	51	March 01 2024
	52	March 01 2024
	53	March 01 2024
	54	March 01 2024
	55	March 01 2024
	56	March 01 2024
	57	March 01 2024
	58	March 01 2024

BRP-Rotax
MAINTENANCE MANUAL LINE

Chapter	Page	Date
	59	March 01 2024
	60	March 01 2024
	61	March 01 2024
	62	March 01 2024
	63	March 01 2024
	64	March 01 2024

Chapter	Page	Date
	65	March 01 2024
	66	March 01 2024
	67	March 01 2024
	68	March 01 2024
	Index	
	Rear page	

BRP-Rotax
MAINTENANCE MANUAL LINE

Chapter: TOA
TABLE OF AMENDMENTS

Approval*

The technical content of this document is approved under the authority of the DOA ref. EASA.21J.048.

NOTE

THE APPROVAL IS GIVEN TO ALL CHAPTERS EXCEPT THE AIRWORTHINESS LIMITATIONS SECTION 04-00-00 WHICH IS SUBJECT TO SPECIFIC APPROVAL OF THE EASA.

Edition 3 / Rev. 0 March 01 2024

Rev. no.	Chapter	Page	Date of change	Remark for approval	Date of approval from authorities	Date of inclusion	Signature
0	INTRO	all	March 01 2024	DOA*			
0	LEP	all	March 01 2024	DOA*			
0	TOA	all	March 01 2024	DOA*			
0	00-00-00	all	March 01 2024	DOA*			
0	04-00-00	all	March 01 2024	EASA approved			
0	05-00-00	all	March 01 2024	DOA*			
0	05-10-00	all	March 01 2024	DOA*			
0	05-20-00	all	March 01 2024	DOA*			
0	05-50-00	all	March 01 2024	DOA*			
0	12-00-00	all	March 01 2024	DOA*			
0	12-10-00	all	March 01 2024	DOA*			
0	12-20-00	all	March 01 2024	DOA*			

BRP-Rotax
MAINTENANCE MANUAL LINE

Summary of amendments

Summary of the relevant amendments in this context, but without requirement on completeness.

no.	chapter	page	date of change	comment
0	all	all	March 01 2024	New layout and change of company name, change of text and graphics.
0	05-20-00	9-16	March 01 2024	Change of maintenance schedule
0	05-50-00	7-11	March 01 2024	New: Propeller strike inspection

BRP-Rotax
MAINTENANCE MANUAL LINE

Chapter: 00-00-00
GENERAL NOTE

TOPICS IN THIS CHAPTER

General	2
Abbreviations and terms (depending on respective engine type)	3
Wiring color codes	8
Conversion table	9
Safety notice	10
Safety information	11
Instruction	13
Maintenance Concept.....	14
Technical documentation.....	15
Use for intended purpose	17

BRP-Rotax MAINTENANCE MANUAL LINE

GENERAL

In this Manual all ROTAX® 914 Series engines are described.

NOTE

ROTAX® 914 Series includes 914 F and 914 UL.

Purpose

The purpose of this Manual is to provide aircraft manufacturers with technical requirements (e.g. interface descriptions and limitations) that must be adhered to when installing this type of engine into an aircraft or certifying aircraft powered by this engine type. Furthermore it should allow independent ROTAX® Maintenance Technicians (iRMT) to maintain this engine in compliance with the relevant maintenance and safety instructions provided by the engine manufacturer.

For detailed information related to aircraft and aircraft/engine installation, maintenance, safety or flight operation, consult the documentation provided by the aircraft manufacturer and/or its dealer.

For additional information on engines, their maintenance or parts, you can also contact your nearest authorized ROTAX® authorized Aircraft Engine Distributor or their independent Service Center.

ROTAX® Distributors

For ROTAX® Authorized Distributors for aircraft engines see latest Operators Manual (OM) or the official website www.FLYROTAX.com.

Engine serial number

When making inquiries or ordering parts, always indicate the engine serial number. Due to continuous product improvement, engines of the same engine type might require different support and spare parts. The engine number is on the ignition cover, on the left, opposite the electric starter.

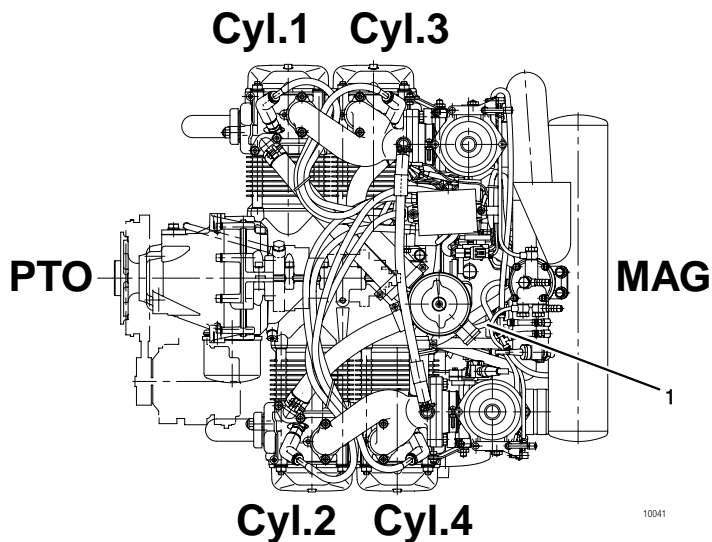



Figure 1.1: Engine serial number

1 Engine serial number

BRP-Rotax
MAINTENANCE MANUAL LINE

ABBREVIATIONS AND TERMS (DEPENDING ON RESPECTIVE ENGINE TYPE)

Abbreviations	Description
*	Reference to another section
	center of gravity
	The drop symbol indicates use of sealing agents, adhesives or lubricants (only in the Maintenance Manual Heavy)
°C	Degrees Celsius (Centigrade)
°F	Degrees Fahrenheit
rpm	Revolutions per minute
A	Ampere
AAPTS	Ambient Air Pressure Temperature Sensor
AC	alternating current
AD	Airworthiness Directives
Ah	Ampere hour
A/C	Aircraft
AC-DC	EMS Modul voltage converter
AR	as required
assy.	assembly
ASB	Alert Service Bulletin
ACG	Austro Control GmbH
ACL	Anti Collision Light
API	American Petrol Institute
ASTM	American Society for Testing and Materials
ATA	Air Transport Association
AWG	American Wire Gauge
CAN	Controller Area Network
CCS	Camshaft position sensor
Coil 1–4	Ignition coils 1–4
CPS 1+2	Crankshaft Position Sensor 1+2
CSA	Constant Speed Actuator
CTS	Cooling Temperature Sensor

BRP-Rotax
MAINTENANCE MANUAL LINE

Abbreviations	Description
CW	clockwise
CCW	counter-clockwise
CGSB	Canadian General Standards Board
DCDI	Dual Capacitor Discharge Ignition
DC	direct current
DOA	Design Organisation Approval
DOT	Department of Transport
EASA	European Aviation Safety Agency
IM	Installation Manual
ECU	Engine Control Unit
EGT	Exhaust Gas Temperature
INTRO	Introduction
EMS	Engine Management System
EMS GND	Engine system internal ground reference which is intended to be disconnected from aircraft common ground during flight
EMC	Electromagnetic compatibility
EN	European Standard
ETFE	Ethylene Tetrafluoroethylene
FAA	Federal Aviation Administration
FAR	Federal Aviation Regulations
FOD	Foreign object damage
FL	Flight Level
Fuse box	Power conditioning and distribution for the Engine Management System
hr.	hours
HIC A	Harness Interface Connector A
HIC B	Harness Interface Connector B
IAT	Indicated Air Temperature
ICA	Instructions for Continued Airworthiness
IFR	Instrument Flight Rules
IFSD	In-flight-shutdown
INJ 1–8	Injector 1–8

BRP-Rotax MAINTENANCE MANUAL LINE

Abbreviations	Description
IPC	Illustrated Parts Catalog
ips	inch per second
iRMT	independent ROTAX Maintenance Technician
ISA	International Standard Atmosphere
kg	Kilograms
KNOCK	Knock sensor
Lane A	System A of Engine Management System
Lane B	System B of Engine Management System
LOPC	Loss of power control
MAPS 1 & 2	Manifold Air Pressure Sensor 1 & 2
MATS 1 & 2	Manifold Air Temperature Sensor 1 & 2
MCON 1.2	Sealed electrical connector
MON	Motor Octane Number
MAG	Magneto Side
N	Newton
n.a.	not available
NDT	Non Destructive Testing
NEW	Part must be replaced against NEW (mentioned in figures)
Nm	Newtonmeter
NVFR	Night Visual Flight Rules
OAT	Outside Air Temperature
OHM	Overhaul Manual
OHV	Over Head Valve
OM	Operators Manual
OPS	Oil Pressure Sensor
OTS	Oil Temperature Sensor
PCD	Pitch Circle Diameters
PCV	Pressure Control Valve
PMA	Permanent magnet alternator
POA	Production Organization Approval
PS	Power supply

BRP-Rotax
MAINTENANCE MANUAL LINE

Abbreviations	Description
PTFE	Polytetrafluoroethylene (Teflon)
PTO	Power Take Off
Rev.	Revision
ROTAX®	is a trademark of BRP-Rotax GmbH & Co KG
RON	Research Octane Number
RON 424	ROTAX® Standard 424
s.v.	still valid (only Illustrated Parts Catalog)
S/N	Serial Number
SAE	Society of Automotive Engineers
SEP	Single Engine Piston
SB	Service Bulletin
SI	Service Instruction
SI-PAC	Service Instruction Parts and Accessories
SPST	Single pole single throw
STP	Shielded twisted pair wire
SL	Service Letter
SMD	Surface Mounted Devices
TBO	Time Between Overhaul
TC	Type certificate
part no.	part number
TOA	Table Of Amendments
TOC	Table Of Contents
TPS	Throttle Position Sensor
TSN	Time Since New
TSNP	Time Since New Part
TSO	Time Since Overhaul
V	Volt
VFR	Visual Flight Rules
LEP	List of Effective Pages
MM	Maintenance Manual
MEP	Multi Engine Piston















BRP-Rotax
MAINTENANCE MANUAL LINE

Abbreviations	Description
X3	Connector on Engine Management System wiring harness which serves as an interface for power supply
XXXX	shows the component serial number

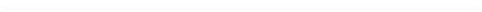
WIRING COLOR CODES

IEC 60757

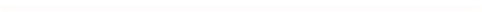
Color codes (wiring)

black		BK
brown		BN
red		RD
orange		OG
yellow		YE
green		GN
blue		BU
violet		VT
gray		GY
white		WH
pink		PK
turquoise		TQ
Light blue		LBU
Dark blue		DBU
gold		GD
silver		SR
green-yellow		GNYE

10336

Figure 1.2

BRP-Rotax
MAINTENANCE MANUAL LINE

CONVERSION TABLE

Units of length:	Units of power:
1 mm = 0.03937 in 1 in = 25.4 mm 1 ft = 12 in = 0.3048 m	1 kW = 1.341 hp 1 hp = 0.7457 kW 1 kW = 1.3596 PS 1 PS = 0.7355 kW
Units of area:	Units of temperature:
1 cm ² = 0.155 sq. in (in ²) 1 sq. in (in ²) = 6.4516 cm ²	0 K = °C – 273,15 °C = (°F – 32) / 1,8 °F = (°C x 1.8) +32
Units of volume:	Units of velocity:
1 cm ³ = 0.06102 cu in (in ³) 1 cu in (in ³) = 16.3871 cm ³ 1 dm ³ = 1 l 1 dm ³ = 0.21997 gal (UK) 1 gal (UK) = 4.5461 dm ³ 1 dm ³ = 0.26417 gal (US) 1 gal (US) = 3.7854 dm ³	1 m/s = 3.6 km/h 1 ft/min = 0.3048 m/min = 0.00508 m/sec 1 m/s = 196.85 ft/min 1 kt = 1.852 km/h 1 km/h = 0.53996 kn
Units of mass:	spec. fuel consumption:
1 kg = 2.2046 lbs. 1 lb. = 0.45359 kg	1 g/kWh = 0.001644 lb/hph 1 lb/hph = 608.277 g/kWh
Density:	Units of torque:
1 g/cm ³ = 0.016018 lb/ft ³ 1 lb/ft ³ = 62.43 g/cm ³	1 Nm = 0.737 ft lb = 8.848 in lb 1 ft lb = 1.356 Nm 1 in lb = 0.113 Nm
Units of force:	Cable cross-section: Conversion table- Wire Gauge: AWG-mm²
1 N = 0.224809 lbf 1 lbf = 4.4482 N	AWG → mm ² 4 → 21 6 → 13 8 → 8.4 10 → 5.3 12 → 3.3 14 → 2.1 16 → 1.3 18 → 0.8 20 → 0.52
Units of pressure:	
1 Pa = 1 N/m ² 1 bar = 100 000 Pa / 1000 hPa / 100 kPa 1 bar = 14.503 lbf/in ² (psi) 1 in Hg = 33.8638 hPa	

BRP-Rotax
MAINTENANCE MANUAL LINE

SAFETY NOTICE

Although reading such information does not eliminate any hazards, it promotes understanding, and applying of the information will promote correct use of the engine. Always apply common workshop safety rules.

The information and descriptions of components and systems contained in this Manual are correct at the time of publication. BRP-Rotax maintains a policy of continuous improvement of its products without imposing upon itself any obligation to retrofit products previously manufactured.

Revisions

BRP-Rotax reserves the right to remove, replace or discontinue any design, specification, feature or other at any time, and without incurring obligation.

Measurement

Specifications are given in the SI metric system with the imperial- and US customary measurement system equivalents in parenthesis.

Symbols used

This Manual uses the following symbols to emphasize particular information. This information is important and must be observed.

⚠ WARNING
Identifies an instruction which, if not followed, may cause serious injury or even fatal injury.

⚠ CAUTION
Identifies an instruction which, if not followed, may cause minor or moderate injury.

NOTICE
Identifies an instruction which, if not followed, may severely damage the engine or could void any warranty.

NOTE

Indicates supplementary information which may be needed to fully complete or understand an instruction.

ENVIRONMENTAL NOTE
Environmental notes give you tips on environmental protection.

A revision bar outside the page margin indicates a change to text or graphic.

BRP-Rotax MAINTENANCE MANUAL LINE

SAFETY INFORMATION

Use for intended
purpose

⚠ WARNING

Non-compliance can result in serious injuries or death!

The user has to assume all risks possibly arising from utilizing auxiliary equipment.

⚠ WARNING

Non-compliance can result in serious injuries or death!

Never fly the aircraft equipped with this engine at locations, air speeds, altitudes or in other situations which do not allow a successful no-power landing after sudden engine stoppage.

- This engine is not suitable for aerobatics (inverted flight, etc.). Flight attitudes outside the permissible limits are not allowed
- This engine has exclusively been developed and tested for fixed wing, gyrocopter, pusher and tractor applications. In case of any other usage, the OEM is responsible for testing and the correct function of the engine
- It should be clearly understood that the choice, selection and use of this particular engine on any aircraft is at the sole discretion and responsibility of the aircraft manufacturer, assembler or owner/user
- Due to the varying designs, equipment and types of aircraft, BRP-Rotax grants no warranty on the suitability of its engines use on any particular aircraft. Further, BRP-Rotax grants no warranty on this engines suitability with any other part, component or system which may be selected by the aircraft manufacturer, assembler or user for aircraft application
- Unless correctly equipped to provide enough electrical power for night VFR (according to latest requirement as ASTM), the ROTAX® 914 UL is restricted to DAY VFR only

⚠ WARNING

Non-compliance can result in serious injuries or death!

For each use of DAY VFR, NIGHT VFR or IFR in an aircraft the applicable legal requirements and other existing regulations must be adhered to.

- In addition to observing the instructions in our Manual, general safety and accident precautions, legal regulations and regulations of any aeronautical authority must be observed
- Where differences exist between this Manual and regulations provided by any authority, the more stringent regulation shall be applied
- For continued airworthiness see Maintenance Manual Line (MML)

BRP-Rotax

MAINTENANCE MANUAL LINE

- Unauthorized modifications of engine or aircraft will automatically exclude any liability of the engine manufacturer for consequential damage
- This engine may be equipped with a vacuum pump. The safety warning accompanying the air pump must be given to the owner/operator of the aircraft into which the air pump has been installed

Engine operation

- The engine must always be operated according to the content of the latest Operators Manual (OM)
- To eliminate the risk of injury or damage, ensure any loose equipment or tools are properly secured before starting the engine
- The use of propellers and their fastenings which exceed the specified values of moment of inertia and imbalance is not allowed and releases the engine manufacturer from any liability
- Improper engine installation, use of unsuitable piping for fuel, cooling and lubrication system and use of unsuitable wiring for electric and engine management system releases the engine manufacturer from any liability

BRP-Rotax MAINTENANCE MANUAL LINE

INSTRUCTION

Engines require instructions regarding their installation, application, use, operation, maintenance and repair.

Technical documentation and regulations are useful and necessary complementary elements for trainings, but can by no means substitute for theoretical and practical instructions.

These instructions should cover explanation of the technical context, advice for operation, maintenance, installation, use and operational safety of the engine.

Safety notice

In this technical Manual passages concerning safety are especially marked. Pass on safety warnings to other users!

Accessories

This engine must only be operated with accessories supplied, recommended and released by BRP-Rotax. Modifications are only allowed after consent of the engine manufacturer.

Spare parts



See Illustrated Parts Catalog (IPC), latest issue for the respective engine type.

NOTICE

Only use GENUINE ROTAX® spare parts. Spare parts must meet the requirements defined by the engine manufacturer. This can only be guaranteed when using spare parts and/or accessories. Spare parts are available at Authorized Distributors and their independent Service Centers. Any warranty by will become void if spare parts and/ or accessories other than spare parts and/or accessories are used (see latest Warranty Conditions).

See relevant Service Letter on www.flyrotax.com.

Standard tools / Special tools

NOTICE

Only use tools and appliances which are suitable for the relevant task according to the latest Manuals.

State of delivery

⚠ WARNING

Engine and gearbox are delivered in “dry“ conditions (without fuel, oil and coolant).

Before putting the engine into operation it must be filled with oil and cooling liquid. Use only oil and coolant as specified.



See latest Operators Manual (OM) and Service Instruction SI-914-019 “Selection of suitable operating fluids“, current issue.

BRP-Rotax
MAINTENANCE MANUAL LINE

MAINTENANCE CONCEPT

General note The maintenance functions detailed in this Manual are divided into two categories:

- Maintenance I (Line Maintenance)
- Maintenance II (Heavy Maintenance)

**Maintenance I
(Line
Maintenance)**

Chapter 00,05 and 12

The scope of line maintenance consists of servicing and adjustment of engine components (including part wear). All procedures in this Manual are to be considered line maintenance.

NOTE

Where applicable, you will be referred to the Maintenance Manual Heavy (MMH) for work above and beyond line maintenance.

**Maintenance II
(Heavy
Maintenance)**

Separate Manual.

Maintenance Manual II details removal, installation and repair of components or parts normally considered beyond the scope of "Line Maintenance".

NOTE

This Manual can only be used in combination with Maintenance Manual I (Line Maintenance), as it builds upon it.

BRP-Rotax MAINTENANCE MANUAL LINE

TECHNICAL DOCUMENTATION

These documents form the instructions ensuring continued airworthiness of ROTAX® aircraft engines.

The information contained herein is based on data and experience that are considered applicable for authorized mechanics (iRMT, see MML, Chapter 05–00–00 section “Authorized Personnel”) under normal conditions for engine removal and installation. Concerning design of engine installation in depth knowledge of aircraft design is required.

Due to the fast technical progress and fulfillment of particular specifications of the customers it may occur that existing laws, safety prescriptions, constructional and operational regulations may not be sufficient or cannot be transferred completely to the object bought, in particular for special constructions.

Documentation

- Installation Manual (IM)
- Operators Manual (OM)
- Maintenance Manual Line (MML)
- Maintenance Manual Heavy (MMH)
- Overhaul Manual (OHM)
- Illustrated Parts Catalog (IPC)
- Alert Service Bulletin (ASB)
- Service Bulletin (SB)
- Service Instruction / Service Instruction-Parts and Accessories (SI-PAC)
- Service Letter (SL)



Status

The status of the Manuals can be determined by checking the table of amendments. The first column of this table indicates the revision status, which should be compared with the revision provided on the ROTAX®-Website: www.FLYROTAX.com
Amendments and current versions can be downloaded free of charge.

Replacement pages

Furthermore the Manual is constructed in such a way that single pages can be replaced instead of the complete document. The list of affected pages is given in the chapter LEP. The particular edition and revision number is given on the footer of each page.

Reference

This Manual is only part of the technical documentation and will be supplemented by the respective Operators Manual (OM), Maintenance Manuals and Illustrated Parts Catalog (IPC).

NOTICE

Pay attention to references to other documentation, found in various parts of this Manual.

If not stated otherwise, any reference to a document refers to the latest edition issued by BRP-Rotax.

BRP-Rotax

MAINTENANCE MANUAL LINE



This symbol informs you of additional references (data sheets, Manuals, etc.) associated with the given subject.

Illustrations

The illustrations in this Manual are merely sketches and show typical arrangements. They may not represent full detail or the exact shape of the parts but should outline the same or similar function. Therefore deriving dimensions or other details from illustrations is not permitted.

TYPICAL indicates a general view which may not represent exact details.

NOTE

The Illustrations in this Manual are stored in a graphic database system and are provided with a consecutive, irrelevant, number.

This number (e.g. AE 5iS001) is of no significance for the content.

Some measurements are given in the drawings, these are manufacturing dimensions and are subject to corresponding tolerances.

Installation drawings

Installation drawings and a “digital mock-up (DMU) model” for (virtual) installation analysis are available from the ROTAX® Authorized Distributors or their independent Service Centers on special request and relevant non disclosure and copyright regulations.

The illustrations in this Manual show a possible installation variant including non certified parts.

BRP-Rotax
MAINTENANCE MANUAL LINE

USE FOR INTENDED PURPOSE

⚠ WARNING
Explosion hazard. Flying components can cause serious injuries. Never run an engine without propeller.

Use The engine ROTAX® / 914 F is intended for use in certified aircraft. In case of doubt the regulations of the national authorities or the respective sportive federations have to be observed.

Certified engines The certified aircraft engine ROTAX® / 914 F has been tested as per aeronautical standards for safety and time between overhaul. It was developed to conform to the latest technological standards and has been rigorously tested.

Non certified engines The ROTAX® 914 UL are not type certified. These engines have not received any aeronautical standards or regulatory safety or durability testing, and do not conform to any aircraft standards. These engines are meant for use in experimental, uncertificated aircraft and vehicles only in which an engine failure will not compromise safety.

NOTE

These engines are technically equivalent to certified engines and have been manufactured by BRP-Rotax using the same quality assurance system.

Engine stoppage In using the engine the operator assumes all risk of use and acknowledges that he/she knows this engine is subject to sudden stoppage.

Maintenance and repair conditions Use for intended purpose also includes observation of the operational, maintenance and repair conditions prescribed by the manufacturer. This is a crucial factor concerning the reliability of the engine and can increase the durability of the engine.

BRP-Rotax
MAINTENANCE MANUAL LINE

INTENTIONALLY LEFT
BLANK

BRP-Rotax
MAINTENANCE MANUAL LINE

Chapter: 04-00-00
AIRWORTHINESS LIMITATIONS

TOPICS IN THIS CHAPTER

Approval							
THE AIRWORTHINESS LIMITATIONS SECTION IS APPROVED BY THE EUROPEAN UNION AVIATION SAFETY AGENCY (EASA) IN ACCORDANCE WITH PART 21A.31 (a)(3) AND FAR 33.4. ANY CHANGE TO MANDATORY REPLACEMENT TIME, INSPECTION INTERVAL, AND RELATED PROCEDURES CONTAINED IN THIS AIRWORTHINESS LIMITATIONS SECTION MUST ALSO BE APPROVED.							
rev. no.	chapter	page	date of change	remark for approval	date of approval from authorities	date of issue	signature
0	04-00-00	all	March 01 2024	EASA approved			

Introduction

This chapter 04-00-00 provides information about “Airworthiness Limitations”.

Airworthiness Limitations

— NONE

For the ROTAX® engine type 914 Series the airworthiness limitations are not applicable.

NOTE

Regarding engine operating limitations see the relevant chapter “Limits of Operation” in the relevant Operators Manual (OM).

Maintenance checks and replacement of defined components are required on this engine! These procedures are described in chapter 05 and are required by the authorities in order to ensure Continued Airworthiness!

See [Chapter 05-00-00 Maintenance](#).

Continued Airworthiness

Scheduled inspections of the engine including replacement and overhaul of defined components are required in order to ensure Continued Airworthiness of ROTAX® aircraft engines.

BRP-Rotax
MAINTENANCE MANUAL LINE

INTENTIONALLY LEFT
BLANK

BRP-Rotax
MAINTENANCE MANUAL LINE

Chapter: 05-00-00
MAINTENANCE

TOPICS IN THIS CHAPTER

General note	2
Authorized personnel	4
Procedure notes	5
Troubleshooting	7
Consumable Materials	8
Acceptable methods, techniques and practice	12

Introduction

The information given in the Maintenance Manual is based on data and experience which are considered to be applicable for a skilled aviation mechanic (iRMT) under normal working conditions.

BRP-Rotax
MAINTENANCE MANUAL LINE

GENERAL NOTE

⚠ WARNING

Non-compliance can result in serious injuries or death!

Besides our instructions in the documentation supplied, also respect generally valid safety and accident preventive directives and legal regulations.

Procedures and limits	The procedures and limits in this Manual constitute the manufacturers official recommendation for engine maintenance and operation.
Instruction	The guidelines given in the Maintenance Manual are useful and necessary supplements to training. They, however, cannot substitute competent theoretical and practical personal instruction.
Modifications	Non-authorized modifications as well as the use of components and auxiliary components not corresponding to the installation instructions exclude any liability of the engine manufacturer.
Parts and accessories	We particularly emphasize that parts and accessories not supplied as genuine BRP-Rotax parts are not verified for suitability by BRP-Rotax and thus are not authorized for use. Installation and/or use of such products may possibly change or negatively influence the constructive characteristics of the engine. For damages resulting from use of non-genuine parts and accessories manufacturer refuses any liability.
Special tools	Maintenance of engines and systems requires special knowledge and special tools. Use only the special tools recommended by BRP-Rotax when disassembling and assembling the engine.
Tightening torques	Tighten fasteners to the torque specified in the exploded view(s) and/or in the written procedure. Accepted accuracy for different measuring tools: Torque: +/- 10% :

⚠ WARNING

Non-compliance can result in serious injuries or death!

Exactly observe the tightening torques for screws and nuts. Overtightening or a connection which is too loose could cause serious engine damage.

In order to avoid a poor assembly, tighten screws, bolts, or nuts in accordance with the following procedure:

- Manually screw all screws, bolts and/or nuts
- Apply half the recommended torque value
- Tighten fastener to the recommended torque value

BRP-Rotax
MAINTENANCE MANUAL LINE

NOTICE

Be sure to use the recommended tightening torque for the specified fastener.

NOTE

When possible, always apply torque on the nut.

NOTE

Always torque screws, bolts and/or nuts using a crisscross pattern when multiple fasteners are used to secure a part. Some parts must be torqued according to a specific sequence and torque pattern as detailed in the installation procedure.

NOTICE

If not specified otherwise, the threads are not lubricated when fastened.

Measuring tools

Calliper rule, dial gauge indicator, micrometer, inner micrometer, inner fine measuring device, feeler gauge, spring scale up to 50 kp (500 N) (112.5 lbf).

Accepted accuracy for different measuring tools:

Pressure: +/- 5%

Distances:

- Inside micrometer or similar: +/- 0.01 mm (0.0004 in.)
- Digital caliper or similar: +/- 0.001 mm (0.00004 in.)
- Bow micrometer or similar: +/- 0.002 mm (0.000079 in.)
- Caliper or similar: +/- 0.03 mm (0.0012 in.)

The changes above are accounting for:

- variations/errors of tools (when used in normal operating conditions)
- accuracy of tools and their related tolerance

Calibration

The professional calibration of your torque wrench is an essential prerequisite for ensuring the quality of the tightening torques in the long term. Calibration is also a fundamental part of ISO 9001 certification.

BRP-Rotax
MAINTENANCE MANUAL LINE

AUTHORIZED PERSONNEL

General note

It is a requirement that all appropriately rated persons organizations/entities or individuals possess the required special tooling. Technicians must have type-specific training according to the Information on the globally standardized iRMT training program for ROTAX® aircraft engine and keep a recurrent knowledge status for the level of work they intend to perform. Technicians may require accreditation from their local aviation authority in addition to any BRP-Rotax requirements.

Requisite knowledge

Any task outlined herein may be performed if the appropriately rated persons organizations/entity or individual has met the following conditions:

Requisite knowledge of the task as a result of:
<ul style="list-style-type: none">• Type-specific training (for the applicable ROTAX® aircraft engine) which is approved by the national aviation authorities and/or BRP-Rotax• Type-specific training as per ROTAX® iRMT program, covering the relevant level/rating for the applicable ROTAX® aircraft engine along with adequate practical experience in performing the task
Appropriately rated persons or organizations/entities must:
<ul style="list-style-type: none">• maintain a suitable work environment to prevent contamination or damage to engine parts or modules• use the required tools and fixtures as outlined in the ROTAX® Maintenance Manual• ensure reasonable and prudent maintenance practices are utilized• ensure the requirements of the applicable regulatory authority regarding running a maintenance organization are met

For more detailed information, maintenance organizations and individuals are encouraged to contact BRP-Rotax through its worldwide distribution network for information and guidance on any of the tasks outlined herein.

See [Chapter 00-00-00 section Technical Documentation](#).

PROCEDURE NOTES

General note

⚠ WARNING

Non-compliance can result in serious injuries or death!
When carrying out maintenance and service work, respect all safety regulations.

Ignition “OFF”

⚠ WARNING

Non-compliance can result in serious injuries or death!
This precautionary measure serves to avoid any injuries in case of an unintentional start of the engine.

Principally ensure the following at each maintenance event

- Ignition is “OFF” and system grounded,
- Disconnect battery
and secure engine against unintentional operation.

Ignition “ON”

⚠ WARNING

Risk of electric shock!
The ignition is **switched on**, as long as the ground-cable (P lead) is not properly connected to ground.

At maintenance work which requires ignition “ON” and battery connected, take care of the following:

- Secure the propeller against unintentional turning by hand and
- Secure and observe propeller zone

Handling of operating fluids

⚠ WARNING

Risk of burns and scalds. Hot engine parts.
Always allow engine to cool down to ambient temperature before starting work.

At maintenance of cooling, lubricating and fuel system take care that no contamination, metal chips, foreign material and/or dirt enters the system.

BRP-Rotax
MAINTENANCE MANUAL LINE

Disassembly

At disassembly of the engine, mark the components as necessary to avoid any mix-up. Take care of these marks, don't ruin them.

Tool

NOTICE

In order to avoid mechanical damage, always loosen or tighten screws and nuts with specified tools.

Safety wiring

NOTICE

If during disassembling/reassembling the removal of a safety item (e.g. safety wiring, self-locking fastener, etc.) should be necessary, it must always be replaced by a new one.

Cleaning of parts

NOTICE

All metal and synthetic parts should be cleaned with suitable cleaning agents. Before using new and unknown cleaning agents, check their compatibility with the materials they are being used on.

Removed parts

Before re-using disassembled parts, clean, check and refit them as per instructions. Use clean screws and nuts. Always inspect the contact face and thread for damage. If unsure, use new parts.

Self-securing nuts

Once loosened, always replace self-securing nuts.

⚠ WARNING

Non-compliance can result in serious injuries or death!

Exactly observe the tightening torques for screws and nuts. Overtightening or a connection which is too loose could cause serious engine damage.

Sealing rings, O-rings

At reassembly of the engine, replace all sealing rings, gaskets, securing elements, O-rings and oil seals.

Re-assembly

Before re-assembly check components for missing parts. Only use adhesives, lubricants, cleaning agents and solvents indicated in the maintenance instructions. Failure to comply may result in damage.

BRP-Rotax
MAINTENANCE MANUAL LINE

TROUBLESHOOTING

General notes

Possible problems are listed in the Operators Manual (OM). At the same time, a brief description of the necessary remedial action is given.



See Chapter 4 in the Operators Manual (OM) for engine type 914 Series.

BRP-Rotax
MAINTENANCE MANUAL LINE

CONSUMABLE MATERIALS

General note

NOTICE
Use only the specified or technically equivalent materials for all maintenance work.

NOTICE
When handling chemicals, comply with all the customary regulations and specifications of the producer, including the expiry date and instructions of use.



Consider the curing time of the sealing surface compound as stated by the manufacturers instructions.

The materials listed have undergone long term testing and are suitable for all operating conditions indicated by the manufacturer.

No.	Part no.	Description, application	Qty.
AC	899796	LOCTITE 577 Yellow medium duty screw locking agent, oil and coolant tolerant	50 ml (0.013 gal (US))
AG	897186	Silicon heat compound Application of the heat conduction compound will increase heat transfer. The greaselike, temperature-resistant silicone compound fills cavities between components and cooling elements (e.g.: spark plug - cylinder head), which otherwise do not contribute to heat conduction	150 g (0.33 lb)
B	897651	LOCTITE 243 Blue medium duty screw locking agent, oil tolerant	10 ml (0.003 gal (US))
C	899788	LOCTITE 648 Green high temperature screw locking agent + retaining compound	5 ml (0.001 gal (US))
E	297438	LOCTITE ANTI SEIZE 8151 Long-term lubricant for shaft seals	50 ml (0.013 gal (US))
F	n.a.	LOCTITE 7063 For degreasing and cleaning surfaces	AR
H	897870	INTAKE FILTER OIL	14.8 ml (0.004 gal (US))

BRP-Rotax
MAINTENANCE MANUAL LINE

No.	Part no.	Description, application	Qty.
I	897330	LITHIUM-BASE GREASE Electrical isolating	250 g (0.55 lb)
O	n.a.	Engine oil For easier assembly of components or for first lubrication before first engine start	AR
P	899791	LOCTITE 5910 Flange sealant provides flexibility and adhesion	50 ml (0.013 gal (US))
V	898570	Locking paint	20 ml (0.006 gal (US))
Z	899789	LOCTITE 603 Oil tolerant retaining compound, heavy-duty	10 ml (0.003 gal (US))

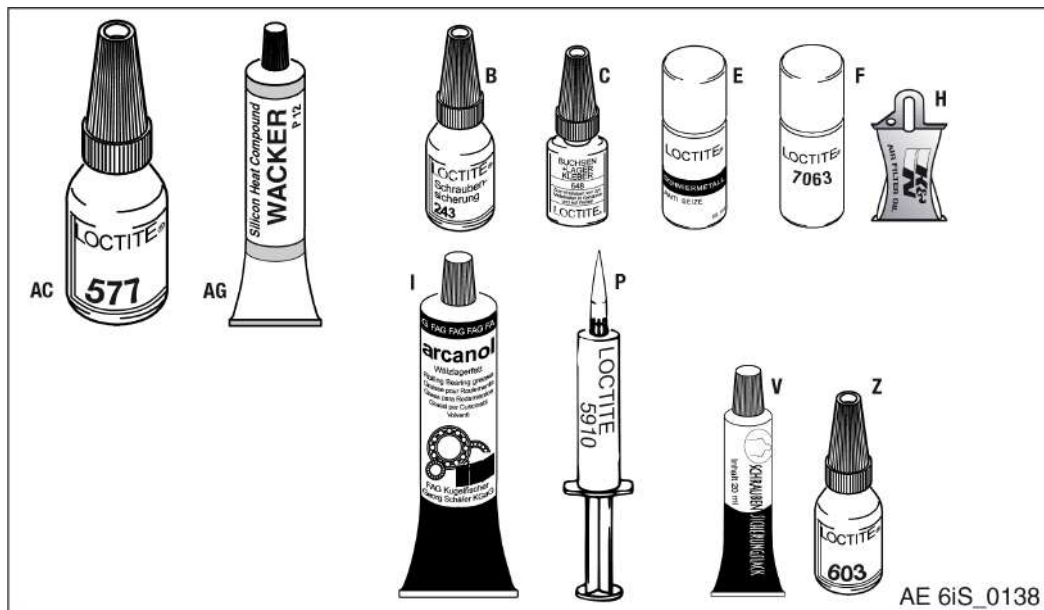

Figure 2.1: Consumable materials

BRP-Rotax
MAINTENANCE MANUAL LINE

**Additional
materials**

NOTICE

All metal and synthetic parts should be cleaned with suitable cleaning agents. Before using new and unknown cleaning agents, check their compatibility with the materials they are being used on.

No.	Part no.	Description, application	Qty.
1	n.a.	<p>Cleaning agent/solvent/parts cleaner Soak combustion chamber, piston and cylinder head with cleaning agent and remove combustion residues with a bronze brush. Cleaning agents that are solvent - cold cleaner, free of halogen, on the basis of selected fuel fractions and biodegradable are recommended. Never use caustic or corrosive cleaning agents.</p>	AR
2	n.a.	<p>Multipurpose grease Generally usable, neutrally colored multipurpose grease, water resistant and highly adherent. Usable for temperatures from -35 °C to +120 °C (-31 °F to 248 °F) and can be subjected to high mechanical loads.</p>	AR
3	n.a.	<p>Preservation oil This special oil has excellent penetrating capabilities and reaches even tiny gaps, its highly effective additives protect against corrosion of metal surfaces.</p>	AR
4	n.a.	<p>Flexible web for surface finishing 3M Scotch-Brite Multi Flex - very fine or ultra fine (or equivalent) Is sold by the meter and used for manual removal of smaller rust spots or oxidation, especially for optimum ground connections. It is particularly suitable for removing LOCTITE from surfaces or threads to make them metallic clean. Before re-applying LOCTITE, clean surfaces with nitrothinner or degreasing agent (CASTROL ZA 30 or OMV - SOFT SOL). When using solvents, observe the safety regulations for persons and the environment.</p>	AR
5	n.a.	<p>MS4 / DC4 corning #4 (or equivalent) Electrical insulation compound for protection of electrical connections.</p>	AR

BRP-Rotax
MAINTENANCE MANUAL LINE

No.	Part no.	Description, application	Qty.
6	n.a.	<p>Valve lapping paste This paste, produced by various manufacturers, is a fine granulate lapping paste for manual lapping of valve seats and valves. The paste is usually available in 3 different granulate sizes. Use as per manufacturers instructions.</p>	AR
7	n.a.	<p>Compressed air blasting using a solid blasting agent This method is suitable for local and gradual very fine treatment of steel parts with rust film (propeller shaft). The Compressed air blasting contains no harmful substances, is approved by the competent authorities and guarantees optimum cleaning. The granulates used are of sizes 40 to 60 μ. The achievable surface roughness is between 0.5 and 1 μ, which corresponds to ultra fine machining of surfaces.</p>	AR

NOTICE
<p>Exhaust valves and intake valves may NOT undergo a compressed air blasting treatment with solid blasting, strong abrasive material. Due to this surface treatment one does gain a microscopic surface roughness/pitting which does allow as a consequence the adhesion of fuel residues. These deposits are then involved in a chemical reaction (especially of the sulfur and lead content of AV-GAS) with the valve material. This effect may cause hot-gas corrosion on the affected parts.</p>

BRP-Rotax
MAINTENANCE MANUAL LINE

ACCEPTABLE METHODS, TECHNIQUES AND PRACTICE

General note All general inspection, maintenance and repair has to be carried out in accordance with Advisory Circular AC 43.13 from FAA.

Advisory Circular This Manual "Advisory Circular" AC describes maintenance methods, techniques and practice. These are recognized and authorized for inspection and repairs in non-pressurized areas for which there are no separate maintenance and repair instructions.

Corrosion Environmental corrosion (on the external surfaces) is a naturally occurring process which can inevitably affect the continued airworthiness of the engine, engine mounted components and accessories. Susceptibility to corrosion is influenced by a number of factors, including but not limited to, geographical location, season and usage. All general preventive (technical) measures, identification, control and treatment of corrosive attack on aircraft structures and engine materials has to be carried out in accordance with Advisory Circular AC 43-4B from FAA and also in accordance with the information of the aircraft manufacturers Instruction for Continued Airworthiness. Furthermore the preservation procedures for stored and inactive aircraft (engines) provides an effective means for combating and minimizing the corrosion condition and should be adhered to.

Advisory Circular AC 43-4B This advisory circular (AC) is a summary of the current available data regarding identification and treatment of corrosive attack on aircraft structures and engine materials. Corrosion inspection frequency, corrosion identification, and especially corrosion treatment continues to be the responsibility of the operator. These inspections should be accomplished per this AC, the manufacturer's recommendations, or the operator's own maintenance program. The procedures in this AC are an acceptable means, but not the only acceptable means, of corrosion treatment. The information in this AC is applicable to aircraft for which the manufacturer has not published corrosion control information.

Self-locking

NOTICE

Self-locking nuts, cotter pins, tab washers and safety wires must be replaced each time they have been removed.

All instructions regarding the securing and lubrication of parts must be observed Adherence to specified torque values is required.

Nut securing When using a self-locking nut, make sure the polyamide insert ring meets the requirements of DIN 985. Be sure that the securing elements the nut is positioned towards the outside, in accordance with DIN 980.

BRP-Rotax
MAINTENANCE MANUAL LINE

Lock washer

NOTE

When fitting lock washers, the curved-up ends (1) must point towards the screw head or nut.

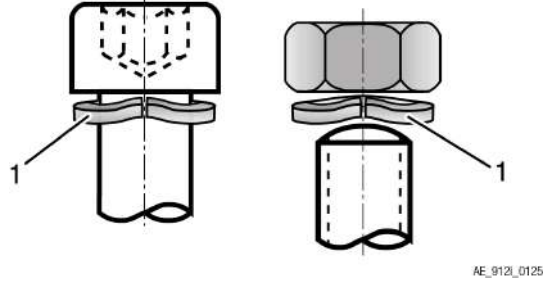

Figure 2.2: Lock washer

BRP-Rotax
MAINTENANCE MANUAL LINE

INTENTIONALLY LEFT
BLANK

BRP-Rotax
MAINTENANCE MANUAL LINE

Chapter: 05-10-00
TIME LIMITS

TOPICS IN THIS CHAPTER

Definition of terms	2
Operating hours	2
Terminology	2
Time limit	2
Life cycle	3
General overhaul (TBO).....	3
Purging the oil system.....	3
Time Limit	4
Time limit for parts	6
Time limit for fuel pump	6
Time limit for the coolant	6
Annual inspection	6

Introduction The following checks are required at the times specified. This preventative maintenance is to help avoid and/or detect possible engine issues.

BRP-Rotax
MAINTENANCE MANUAL LINE

DEFINITION OF TERMS

OPERATING HOURS

Definition All of the maintenance intervals, such as the 100 hr. inspection and the engine TBO, relate to the number of operating hours of the engine.

The operating hours are defined as follows in order to prevent misunderstanding and to ensure safety:

- All time during which the engine is running is counted towards the total number of operating hours.
- The time is counted irrespective of the load factor of the engine, such as idling or take-off power.

In order to prevent misunderstandings and to ensure safety, BRP-Rotax accepts any of the following methods to record operating hours:

- electronic hour meters such as BRP-Rotax TCU

NOTE

Maintenance and overhaul intervals are always dictated by the relevant method used.

NOTE

The planned inspections to be performed at certain intervals are based on experience from long test runs and field observations. They are intended as precautionary maintenance measures in order to ensure continued trouble-free operation of the engine.

TERMINOLOGY

The following terminology is used throughout this Manual, and the meanings are defined as follows:

Inspection An inspection must be done only by certified mechanics who are approved on this engine, using permitted procedures to make an analysis of the physical condition and find defects. An inspection for condition and possible damage must be done in accordance with the accepted procedures for maintenance (refer to FAA "Advisory Circular" AC 43.13).

Check A check can be done by pilots and/or mechanics who are approved on this engine and can perform inspections that compare condition with written standards to make sure of condition, precision and tolerances.

Test A test is the operation of engine components, appliances or systems to make an analysis of performance.

TIME LIMIT

Definition Time limits are predetermined time spans and intervals which are based either on calendar intervals or the number of engine operating hours. Once the time limits have been reached, the affected parts must either be replaced for a general overhaul, or maintenance work must be performed. These precautionary maintenance measures are

BRP-Rotax MAINTENANCE MANUAL LINE

designed to avoid engine malfunctions or defects and ensure continued airworthiness of the engine.

LIFE CYCLE

Definition The life cycle is always specified as an exact time span and is also quoted in flight hours.

NOTE

Parts with a limited life cycle must be taken out of operation and overhauled if the specified time span or number of flight hours is reached (whichever comes first).

GENERAL OVERHAUL (TBO)

Definition The time between overhauls (TBO) for all objects (such as the engine, component assemblies, add-on components) is the approved length of operation under normal operating conditions before it becomes mandatory to send in these objects for an overhaul. Normal operating conditions are the conditions which comply with the manufacturer's and the aviation authority's recommendations for the certification of airworthiness.

Maintenance of operation The TBO values approved by the relevant authorities are based on performance tests and empirical values which have been gathered through operation of the engine and are required for the acceptance and certification of airworthiness. TBO values can be changed in response to possible upgrade/expansion programs.

Legal obligation to keep TBO values for the engine are always shown in operating hours and years. The user must record the operating hours in the engine log book.

PURGING THE OIL SYSTEM

General note Purging of the oil system is extremely important for operation and service life of the engine and therefore the procedure must be followed meticulously.



See Installation Manual (IM) for the engine type 914 Series Chapter 79-00-00 section Purging the lubrication system. It must be carried out in accordance with SI-914-020, "Purging the lubrication system", latest issue.

BRP-Rotax
MAINTENANCE MANUAL LINE

TIME LIMIT

General

NOTICE
A general overhaul is due after a defined period of operation or after a specified calendar life since initial start of operation (whichever comes first).

The time limit for engine operation will be specified by the TBO.

After reaching this time limit

NOTICE
After reaching this time limit, the engine has to be shipped to an authorized overhaul facility.

For an overhaul, the engine must be removed from the aircraft, be cleaned, preserved and all openings to be closed to prevent entering of contaminants.

Storage period of the engine

Observe the storage and preservation directives!

NOTE

The maximum possible storage period of the engine is limited to 24 months.

If this period is exceeded, the engine must be sent to a ROTAX® authorized overhaul facility for inspection.

For the TBO of the specific engine type/version refer to the table below.

Engine Type description	Engine affected engine S/N	TBO Time Between Overhaul
914 F	from S/N 4420001 up to S/N 4420313 incl.	1000 h or 10 years, whichever comes first ¹
914 F	from S/N 4420314 up to S/N 4420908 incl.	1200 h or 12 years, whichever comes first ¹
914 F	from S/N 4420909	2000 h or 15 years, whichever comes first
914 UL	from S/N 4417501 up to S/N 4418103 incl.	1000 h or 10 years, whichever comes first ¹

-
1. Extension of the TBO is possible and will be specified by a Service Bulletin (SB) for the respective engine type. For extensions already in effect refer to the engine log book or release certificate.

BRP-Rotax
MAINTENANCE MANUAL LINE

Engine Type description	Engine affected engine S/N	TBO Time Between Overhaul
914 UL	from S/N 4418104 up to S/N 6773778 incl.	1200 h or 12 years, whichever comes first
914 UL	from S/N 6773779	2000 h or 15 years, whichever comes first

**Authorized
exceeding**

Extension or exceeding of the TBO by 5% or 6 months is allowed, whichever comes first.

Shipment

The shipment to an authorized ROTAX® overhaul facility must include the following:

1	Engine log book.
2	Maintenance records of the engine (i.e. all maintenance check lists, and reports of operation, of maintenance, of findings and of oil analysis).
3	The engine assembly as per supply volume. Additionally all added-on parts as in the supply volume such as filters, intake silencer, fuel pump, external generator, sensors, ignition unit, electric starter, oil tank.
4	Indication of total engine operating hours (TSN) and where applicable, engine operating hours since a previous overhaul (TSO). NOTE <i>This information must be supplied to allow the service history of components to be traced.</i>
5	Data about the type of aircraft used.
6	Useful remarks and observations concerning the engine.

BRP-Rotax

MAINTENANCE MANUAL LINE

TIME LIMIT FOR PARTS

General note

NOTICE

This time limit must be followed independently and in addition to the visual inspections (see Chapter 05-20-00 section: Visual Inspection) of the respective components.

Time limit

The following components and systems must be replaced every 5 years:

- V-belt
- Pressure connecting hoses between carburetors (including hoses from airbox, fuel pressure regulator and 3 way solenoid valve)
- All rubber hoses of the cooling system (except GENUINE ROTAX® silicon hoses) which need to be checked by “on-condition” maintenance according to the instructions of continued airworthiness
- Carburetor rubber flange assy.
- Rubber plate (under coolant expansion tank)
- O-ring 44x2 (between carburetor socket and intake manifold, as applicable)
- Air intake hose (connection between turbocharger and airbox)
- Rubber hoses on induction compensating tube
- All rubber hoses of the lubrication system which are part of the engine supply volume and if they are not in the maintenance schedule of aircraft manufacturer
- Diaphragm on both carburetors

TIME LIMIT FOR FUEL PUMP

General note The fuel pumps must be replaced every 5 years.

TIME LIMIT FOR THE COOLANT

General note Coolant must be replaced as per manufacturers instructions, at the latest during overhaul or when the engine is replaced.

ANNUAL INSPECTION

General note A 100 hr. inspection is to be carried out after every 100 hours of operation **or every 12 months**, whichever comes first.
See [Chapter 05-20-00 section Scheduled maintenance checks](#).

BRP-Rotax
MAINTENANCE MANUAL LINE

Chapter: 05–20–00
SCHEDULED MAINTENANCE CHECKS

TOPICS IN THIS CHAPTER

Scheduled maintenance checks	2
Unscheduled maintenance checks	3
Visual inspection	5
Maintenance schedule procedures (maintenance check list)	6
Check List/Maintenance Schedule.....	7
Maintenance Schedule	9

Introduction The owner and/or user is primarily responsible for the maintenance and airworthiness of the engine. This includes compliance with all applicable airworthiness directives.

This inspection checklist is not intended to be all-inclusive, for no such checklist can replace the knowledge and experience of a certified aircraft technician. As the party primarily responsible for the maintenance and airworthiness of the engine, the owner or user should only have the maintenance work carried out by qualified technicians (corresponding to the iRMT levels).

Documentation required It is the responsibility of the owner and/or user to make sure that the aircraft technician performing the work on the engine has access to the previous inspection checklist and any other required documents.

BRP-Rotax
MAINTENANCE MANUAL LINE

SCHEDULED MAINTENANCE CHECKS

Definition This section lists the periodic inspections which must be carried out after specified periods of operation.

Intervals Periodic inspections are those which must be performed at 25, 100, 200, 600 hr. intervals in accordance with [Chapter 05-20-00 section Maintenance Schedule](#). This means for example that **every 100 hr** of operation a 100 hr. check must be carried out. Every 200 hr. of operation a 100 hr. and the additional checks for 200 hr. must be carried out.

		Intervals –hours								
		25 hr	100 hr	200 hr	300 hr	400 hr	600 hr	700 hr	to	2000 hr
100 hr		X	X	X	X	X	X	X		X
200 hr				X		X	X			
600 hr							X			

- 100 hr. check or annual check**
- In order to demonstrate continued airworthiness, an engine must be inspected after every 100 hours of operation or 12 months.
 - For the intervals between maintenance work, a tolerance of ± 10 hr. is permissible, but these tolerances must not be exceeded. This means that if a 100 hr. check is actually carried out at 110 hr., the next check will be due at 200 hr. ± 10 hr. and not at 210 hr. ± 10 hr.
 - If maintenance is performed before the prescribed interval, the next maintenance check is to be done at the same interval (e.g. if first 100 hr. check is done after 87 hours of operation, the next 100 hr. check must be carried out after 187 hours of operation).
 - If engine has less than 100 hours of operation during one year a 100 hr. check must be carried out. For the annual inspection a tolerance of ± 2 months is given.

Special hr. check **NOTE**
This maintenance schedule contains a column for a 50 hr. check. This check is recommended by the manufacturer but not essential.

- 25-hr. check**
- In order to demonstrate continued airworthiness, an engine must be inspected after the first 25 hours of operation.
 - The checks performed at the 25 hr. inspection are the same as for the 100 hr. inspection. This applies both to newly delivered engines and to overhauled engines.

BRP-Rotax
MAINTENANCE MANUAL LINE

UNSCHEDULED MAINTENANCE CHECKS

Operating limits exceeded

An inspection of the engine must be performed if the operating limits of the engine have been exceeded (e.g. overspeed, excessive temperature etc.), or if unusual operating conditions have occurred during operation (e.g. lightning strike). In such cases the engine must be inspected in accordance with the applicable unscheduled maintenance checks.

Recommends inspections

The manufacturer also recommends the following inspections whenever maintenance is carried out (where not already prescribed by the airframe manufacturer), as possible malfunctions could have negative effects on engine operation.

part	inspection	possible danger
Engine cowling	<ul style="list-style-type: none"> • For discoloring and warping 	Danger of overheating
Exhaust fixation	<ul style="list-style-type: none"> • Re-tighten the exhaust fixation on the cylinder head after the first 2 hr. of operation 	Leakage
Exhaust	<ul style="list-style-type: none"> • Of the exhaust unit (where necessary, replaced application of LOCTITE Anti-Seize) 	Risk of fracture, wear. Smooth engine running.
Fuel filter	<ul style="list-style-type: none"> • Of fuel filter on airframe side (for foreign bodies, sealing material and loose fragmented material) 	Engine may misfire. Power loss. Engine running too lean (Engine malfunction and damage).
Electr. fuel pump	<ul style="list-style-type: none"> • Correct function 	Insufficient fuel supply. Engine running too lean (Engine malfunction and damage).
Battery	<ul style="list-style-type: none"> • Acid concentration for each cell. Observe the manufacturers instruction 	Starting problems
Oil	<ul style="list-style-type: none"> • For oil contamination • Analysis of the oil (provides additional information on the condition of the engine) 	Possible engine wear
Radiators, Lines	<ul style="list-style-type: none"> • For damage • Check for discoloration - and cracks 	Danger of overheating

BRP-Rotax
MAINTENANCE MANUAL LINE

part	inspection	possible danger
Propeller	<ul style="list-style-type: none">• Undamaged and runs true• Carry out dynamically balancing including verification of propeller track	Engine damage, unusual vibrations
Aircraft air intake system (NACA intake)	<ul style="list-style-type: none">• As specified by the aircraft manufacturer	See specifics of manufacturer.
Aircraft attachment points of engine suspension	<ul style="list-style-type: none">• As specified by the aircraft manufacturer	See specifics of manufacturer.
Throttle control	<ul style="list-style-type: none">• As specified by the aircraft manufacturer	See specifics of manufacturer.
Governor	<ul style="list-style-type: none">• As specified by the aircraft manufacturer	See specifics of manufacturer.

BRP-Rotax
MAINTENANCE MANUAL LINE

VISUAL INSPECTION

General note	The scope of a visual inspection generally includes, but is not necessarily limited to, the following:
Moving parts	Normal operating condition, accurate alignment, leak-tightness, cleanliness, ease of movement, adjustment, mechanical stress, travel, catching, extreme wear, cracks, corrosion, deformation and other visually evident damage.
Parts	Secure seating, surface condition, cleanliness, deformation, cracks in welding seams or due to material fatigue or stress, corrosion and other visually evident damage.
Fuel-, Air- and Oil lines and Hoses	Cracks, dents, kinks, required flexibility, collapsed lines/hoses, abrasion, cleanliness, secure seating and other visually evident damage.
Wiring	General cleanliness; loose, corroded or broken terminals; chafed, broken or worn insulation; secure seating, heat damage and other visually evident damage.
Screws and Nuts	Surface damage, secure seating, locking wire, securing paint and other visually evident damage.
Filter and Screens	Filters and screens must be inspected for contamination and potential blockages, cleaned and replaced as required.

BRP-Rotax
MAINTENANCE MANUAL LINE

MAINTENANCE SCHEDULE PROCEDURES
(MAINTENANCE CHECK LIST)

Inspections	All stated checks are visual inspections for damage and wear, unless otherwise stated.
Specified period	All listed work must be carried out within the specified period.
Maintenance check lists	Checks are carried out as per the maintenance check lists, where type and volume of maintenance work is outlined in key words. <ul style="list-style-type: none">• The lists must be photocopied and filled out for each maintenance check.
Extra inspections	<ul style="list-style-type: none">• The respective check (e.g. 100 hr. check) must be noted on the top of each page of the maintenance check list.• All the maintenance work carried out must be initialled in the "signature" area by the aircraft technician performing the task.
Maintenance records	After maintenance, the completed check lists must be entered in the maintenance records. The maintenance must be confirmed in the log book.
Discrepancies/remedial action	All discrepancies and remedial action must be recorded in a report of findings to be generated and maintained by the company authorized to carry out maintenance work. It is the responsibility of the aircraft operator to store and keep the records.
Replacement of equipment	Replacement of equipment (e.g. fuel pump, governor....) and execution of SB (AD) must be entered in the engine log book, stating S/N, TSN and date.

BRP-Rotax
MAINTENANCE MANUAL LINE

CHECK LIST/MAINTENANCE SCHEDULE

Identification	
AIRCRAFT	
Registration number	
Aircraft make	
Aircraft model and S/N	
Time since new	
Propeller	
Propeller brand	
Propeller model and S/N	
Governor brand	
Governor model and S/N	
ENGINE	
Engine type	
Engine S/N	
TSN (time since new)	
TSO (time since overhaul)	
Used operating fluids:	
Coolant	
• mixture ratio	
Fuel	
Oil	
• type	
• viscosity	

BRP-Rotax
MAINTENANCE MANUAL LINE

Identification							
AIRCRAFT OPERATOR							
Name							
Contact							
Address							
Telephone/Fax							
E-mail							
MAINTENANCE FACILITY							
Maintenance workshop							
Address							
Telephone/Fax							
E-mail							
Certificate							
This check is applicable (circle one)	25 hr.	50 hr. ⁽¹⁾	100 hr.	200 hr.	400 hr.	600 hr.	1000 hr.
(1 leaded fuel more than 30% of operation.							
Next check due at:							hr.
	(TSN _____)						(engine hr.)

BRP-Rotax
MAINTENANCE MANUAL LINE

MAINTENANCE SCHEDULE

Perform the following maintenance tasks at the intervals shown in the maintenance check list.
See Chapter 05-20-00 section 25 hr. check.

Legend: X = do the task
 blank = no task required

NOTE

*If the tasks 1-3 are correct continue with the maintenance schedule.
If one of the tasks 1-3 is not fulfilled, the engine must be checked and repaired in accordance with the BRP-Rotax instructions for continued airworthiness.*

Points of Inspection	Interval Operating hours							Chapter Reference	Signature															
* no periodic maintenance (requirement after the first 25 hours of operation)	25*	50	100	200	400	600	1000																	
1) General note																								
All (Alert) Service Bulletins are complied with. If necessary to perform these and documented.	X	X	X	X	X	X	X																	
All SI-PAC (Service Instruction Part and Accessories) for additional GENUINE-ROTAX®- parts and accessories used on the relevant aircraft are complied with. If necessary to perform these and document it.	X	X	X	X	X	X	X																	
2) Differential pressure check																								
Check the compression by the differential pressure method. Test pressure _____ hPa (psi)	X ⁽¹⁾		X ⁽¹⁾	X				12-20-00 Differential compression check																
<table border="1" style="width: 100%; border-collapse: collapse;"> <thead> <tr> <th colspan="5">Pressure drop (% or fraction)</th> </tr> <tr> <th style="text-align: center;">Cyl. #</th> <th style="text-align: center;">1</th> <th style="text-align: center;">2</th> <th style="text-align: center;">3</th> <th style="text-align: center;">4</th> </tr> </thead> <tbody> <tr> <td style="text-align: center;">bar/psi</td> <td></td> <td></td> <td></td> <td></td> </tr> </tbody> </table>	Pressure drop (% or fraction)					Cyl. #	1	2	3	4	bar/psi													
Pressure drop (% or fraction)																								
Cyl. #	1	2	3	4																				
bar/psi																								
(¹ use of leaded fuel more than 30% of operation.																								

BRP-Rotax
MAINTENANCE MANUAL LINE

Points of Inspection	Interval Operating hours							Chapter Reference	Signature
	25*	50	100	200	400	600	1000		
* no periodic maintenance (requirement after the first 25 hours of operation)									
3) Spark plug									
Check that spark plug connectors fit tightly on the spark plugs. Minimum pull-off force is 30 N (7 lb).				X				12-20-00 Inspection of spark plugs	
Remove all spark plugs and check for spark plug defects (deposits, excessive wear melting,...). Replace if defective. Check if GENUINE-ROTAX®- spark plugs are used.	X		X					12-20-00 Remove the spark plugs	
Replacing spark plugs. (² use of leaded fuel more than 30% of operation)				X(²)	X			12-20-00 Installation of spark plug	
4) Inspecting the magnetic plug									
Check the magnetic plug.	X		X					12-20-00 Inspecting the magnetic plug	
5) Inspecting the oil filter									
Remove oil filter from engine. Cut old filter without producing any metal chips and inspect following components for wear, and/or missing material Perform filter mat inspection: Findings. (³ use of leaded fuel more than 30% of operation)	X	X(³)	X					12-20-00 Inspection of the oil filter components	
6) Visual inspection of the engine									
General visual inspection of the engine for damage or abnormalities. Check cooling air duct and cooling fins of the cylinders for obstruction, cracks, wear and good condition.	X		X					12-20-00 Visual inspection	

BRP-Rotax
MAINTENANCE MANUAL LINE

Points of Inspection	Interval Operating hours							Chapter Reference	Signature
	25*	50	100	200	400	600	1000		
* no periodic maintenance (requirement after the first 25 hours of operation)									
Take note of changes caused by temperature influence.									
Inspect temperature sensors and oil pressure sensor for secure fit and signs of wear.	X		X						
Inspect all coolant hoses for damage, including leakage, hardening from heat, porosity, loose connections and secure attachment. Verify routing is free of kinks and restrictions.	X		X					12-20-00 Leakage check	
Carry out visual inspection of leakage bore at the base of the water pump for signs of leakage.	X		X					12-20-00 Leakage check	
Inspect the expansion tank for damage and abnormalities. Check coolant level, replenish as necessary. Inspect radiator cap. Inspect protection rubber on expansion tank base for correct fit.	X		X					12-20-00 Expansion tank, radiator cap	
Inspect the overflow bottle for damage and abnormalities. Verify coolant level, replenish as necessary. Inspect line from expansion tank to overflow bottle for damage, leakage and clear passage. Inspect venting bore in cap of overflow bottle for clear passage.	X		X					12-20-00 Overflow bottle	
Inspect all oil lines for damage, leakage, hardening from heat, porosity, security of connections and attachments. Verify routing is free of kinks and restrictions.	X		X					12-20-00 Leakage check	
Inspect all fuel lines for damage, leakage, hardening from heat, porosity, security connections and attachments. Verify routing is free of kinks and restrictions. Check steel fuel lines for any cracks and/or scuffing marks.	X		X					12-20-00 Checking the fuel lines	

BRP-Rotax
MAINTENANCE MANUAL LINE

Points of Inspection	Interval Operating hours							Chapter Reference	Signature
	25*	50	100	200	400	600	1000		
* no periodic maintenance (requirement after the first 25 hours of operation)									
Inspect the wiring and its connections for secure fit, damage and signs of wear.	X		X					12-20-00 Check of wiring	
Inspect engine suspension and fasteners (GENIUS ROTAX) for secure fit, including damage from heat, deformation, cracks.	X		X					12-20-00 Checking the engine suspension	
Check the airbox (GENIUNE ROTAX). Inspect sensors for tight fit, damage from heat, damage and signs of wear.	X		X						
Checking the air filter.	X		X					12-20-00 Cleaning the dry air filter	
Inspection of the GENUINE ROTAX® exhaust system included in the standard delivery. Inspect for cracks and leaks. NOTE <i>If there is no standard/genuine exhaust system in use, the specifications of the manufacturer must be observed.</i>	X		X						
7) Oil change									
Drain oil from oil tank.	X	X ⁽⁴⁾	X					12-20-00 Oil change, Flushing the oil circuit	
Check the oil tank and clean the oil tank if contaminated.	X	X ⁽⁴⁾	X					12-20-00 Oil change, Cleaning the oil tank	
Refill oil tank with approx. 3 litres of oil. For oil quality, see Operators Manual latest edition.	X	X ⁽⁴⁾	X					12-20-00 Flushing the oil circuit	
Install new oil filter.	X	X ⁽⁴⁾	X					12-20-00	

BRP-Rotax
MAINTENANCE MANUAL LINE

Points of Inspection	Interval Operating hours							Chapter Reference	Signature
	25*	50	100	200	400	600	1000		
* no periodic maintenance (requirement after the first 25 hours of operation)									
								Oil filter change	
(4 in the case more than 30% of operation with leaded fuel e.g.: AVGAS 100LL)									
8) Auxiliary alternator									
On configurations with auxiliary alternator, check the attachment and the V-belt tension.	X		X					12-20-00 Checking the V-belt tension	
9) Checking the carburetors									
Checking the idle speed	X		X						
Checking the ventilation of the float chambers. Any trouble with the float chamber ventilation impairs engine and carburetor function and must therefore be avoided. Check that the passage of the ventilation lines is free and that no kinks can arise.				X					
Check for free movement of the carburetor actuation (throttle lever and starting carburetor). Check that the bowden cable allows the full travel of the throttle lever from stop to stop.	X		X						
Removal/assembly of the two carburetors for carburetor inspection.				X				See Heavy Maintenance 73-00-00	
Check carburetor synchronization. Mechanical and pneumatic synchronization.	X		X						
Check weight of floater. 1/3 _____g 2/4 _____g				X				12-20-00 Check the weight of floats	

BRP-Rotax
MAINTENANCE MANUAL LINE

Points of Inspection	Interval Operating hours							Chapter Reference	Signature
	25*	50	100	200	400	600	1000		
* no periodic maintenance (requirement after the first 25 hours of operation)									
10) Inspecting carburetor sockets and drip tray									
Inspect the carburetor sockets for damage and abnormalities, checking for cracks, wear and good condition. Take note of changes caused by temperature influence. See SB-914-019 — latest edition.				X				See Heavy Maintenance 73-00-00	
11) Checking the propeller gearbox									
Checking the friction torque in free rotation on gearboxes with overload clutch. Actual friction torque _____ Nm (in. lbs) ⁽⁵⁾ use of leaded fuel more than 30% of operation						X ⁽⁵⁾	X	12-20-00 Checking the friction torque	
Check gear set (pittings).							X	See Heavy Maintenance 72-10-00	
Check wear on tooth of overload clutches.							X	See Heavy Maintenance 72-10-00	
12) Flushing the cooling system									
Flushing the cooling system at massive deposits on the expansion tank or radiator cap and/or if the coolant manufacturer required an change interval.	when replacing the coolant							12-20-00 Flushing the cooling system	
13) Engine cleaning									
Engine cleaning.	X		X					12-20-20 Engine cleaning	
14) Checking the air intake system									
Checking the air filter	X		X					12-20-20	

BRP-Rotax
MAINTENANCE MANUAL LINE

Points of Inspection	Interval Operating hours							Chapter Reference	Signature
	25*	50	100	200	400	600	1000		
* no periodic maintenance (requirement after the first 25 hours of operation)									
								Checking air intake system	
15) Liquid level check									
Verify liquid level, replenish as necessary.	X		X					12-10-00 Fluid capacities	
16) Checking the idle speed									
Checking the idle speed.	X		X						
17) Checking the electric fuel pumps									
Check the electric fuel pumps.							X	See Heavy Maintenance 73-00-00	
Replace the main fuel pump.							X	See Heavy Maintenance 73-00-00	
18) Checking the wastegate flap									
Check the wastegate flap for free running and correct position.			X					12-20-00 Checking the wastegate flap	
Check the wastegate bowden cable for free movement and damage.			X					12-20-00 Checking the wastegate flap	
Lubricate the axle (wastegate flap).			X					12-20-00 Checking the wastegate flap	

BRP-Rotax
MAINTENANCE MANUAL LINE

Points of Inspection	Interval Operating hours							Chapter Reference	Signature
	25*	50	100	200	400	600	1000		
* no periodic maintenance (requirement after the first 25 hours of operation)									
19) Engine test run									
Observe the safety instructions!									
Start the engine and run to operating temperature. Limits see Operators Manual (OM) 914 Series. Ignition check at _____ rpm engine speed. Speed drop without LANE: A (Off) _____ rpm B (Off) _____ rpm A/B (difference) _____ rpm Inspect carb heat system. Hit the preheating and make a note of speed drop. Speed drop _____ rpm. Preheating "OFF", engine idle running and make a note of idle speed running _____ rpm. After engine test run, re-tighten the oil filter by hand (only at cold engine). Checks for leaks.	X		X					12-20-00 Test run of engine	
Returning engine to service On the engine identified as per Checklist , a <u>25 hr; 50 hr; 100 hr; 200 hr; 400 hr; 600 hr; 1000 hr</u> (please strike out not applicable intervals) maintenance interval was performed. Check at _____ hr. (TSN____, TSO____) was carried out according to recommendations of the engine manufacturer and was recorded in the Engine Log book. Location, Date _____ Inspector _____ Aircraft mechanic _____ Certificate No. _____									

BRP-Rotax
MAINTENANCE MANUAL LINE

Chapter: 05–50–00
UNSCHEDULED MAINTENANCE CHECKS

TOPICS IN THIS CHAPTER

Engine check after propeller strike incidents	3
Removal of the propeller gearbox	3
Drive gear — removal	6
Propeller Strike Inspection	7
Installation of propeller gearbox	12
Propeller gearbox without integrated overload clutch	17
Checking of the overload clutch	18
Examination after engine failure	21
Returning engine to service after submerging in water	23
Inspection in extreme climatic conditions	25
Returning engine to service after influence by fire	25
Exceeding of max. admissible engine RPM	25
Exceeding of max. cooling system temperature	27
Non compliance with the coolant specification	31
Exceeding the max. permissible oil temperature	32
Oil pressure below minimum value	33
Oil specification not respected	36
Spark plug not in accordance with specification	38
Non compliance of fuel quality	39
Checking of the Cooling system / radiator cap	40
Smooth performance of the engine	46
Sudden drop in boost pressure and speed	47
Sudden increase in boost pressure and speed	48
Periodic rise and fall in boost pressure and speed (vibration of turbo control unit)	48
Red boost lamp of the boost pressure control lights up continuously	49
Red boost lamp of the boost pressure control is flashing	50
Orange caution lamp of the boost pressure control is flashing	52
Failure of the voltage supply for the turbo control unit (TCU)	53
Lightning strike	53
Reporting	54

Introduction Special checks must be carried out before next or further flights in the event of an engine fault (e.g. abnormal operation as defined in the Operators Manual (OM) which impairs the airworthiness of the engine.

BRP-Rotax
MAINTENANCE MANUAL LINE

NOTICE

In the course of special checks specify if additional checks for components (e.g. hydraulic governor) are applicable. After each special check/repair work, an engine test run and a leakage check must be carried out.

NOTICE

Observe without fail all the specified instructions.

ENGINE CHECK AFTER PROPELLER STRIKE INCIDENTS

Definition

A propeller strike is:

- Any incident while the engine is stationary or running which makes it necessary to perform repairs on the propeller.



See Service Letter

SL-914-012, current edition.

REMOVAL OF THE PROPELLER GEARBOX

Preparation

Before the propeller gearbox is removed, the work described below must be carried out to identify any further malfunctions in the propeller gearbox and rectify them as part of repair work.

NOTICE

If these checks are omitted, it may be necessary to dismantle the propeller gearbox again to rectify any faults after it has been repaired.

- General visual inspection. See Chapter 12–20–00
- Engine cleaning. See Chapter 12–20–00
- Carry out an engine test run. See Chapter 12–20–00
- Remove surrounding assemblies and detach oil lines
- Remove external Alternator if installed.

NOTE

The assemblies and lines are only to be removed if necessary and only as far as is necessary!

Step	Procedure
1	Lock the crankshaft into place. See Chapter 12-20-00.
2	Remove eight Allen screws M6 and two Allen screws M8 together with the washers from the gear cover diagonally from each other. The gear cover is aligned with two dowel pins.
3	Install puller part no. 877660 onto the two threaded bolts M8 of the gear cover.
4	The entire propeller gearbox can now be removed without damaging the ball bearing or propeller shaft.

BRP-Rotax
MAINTENANCE MANUAL LINE

NOTICE

When removing the propeller gearbox, take care not to damage the bearing point and the oil seal running surface (on the roller bearing side) of the propeller shaft.

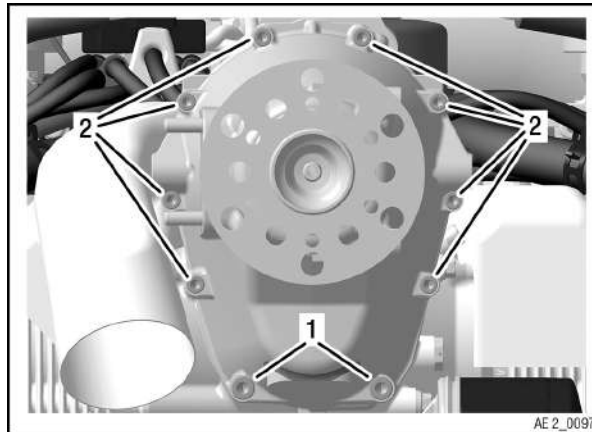

Figure 5.1: Screw position identification

1 Allen screw M8

2 Allen screw M6

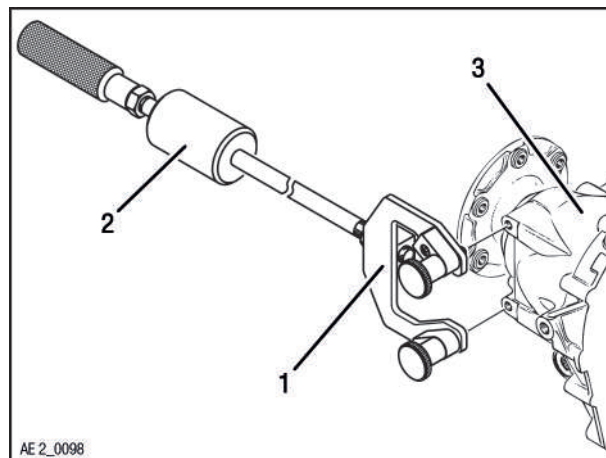

Figure 5.2

1 Puller part no. 877660

2 Handle

3 Gear cover

BRP-Rotax
MAINTENANCE MANUAL LINE

Alternative

NOTE

If desired, the compact special tool part no. 877540 can be used to remove the propeller gearbox.

Step	Procedure
1	Insert the dowel pin 8x20 into the bore on the right and left of the gearbox housing.
2	Install hex. screw M6x40 into the pushing jig assy.
3	Put the pushing jig assy. in the center and fix it with a hex. screw M10x20.
4	Using the hex. screw, press the gearbox housing off from the crankcase simultaneously on the right and left.

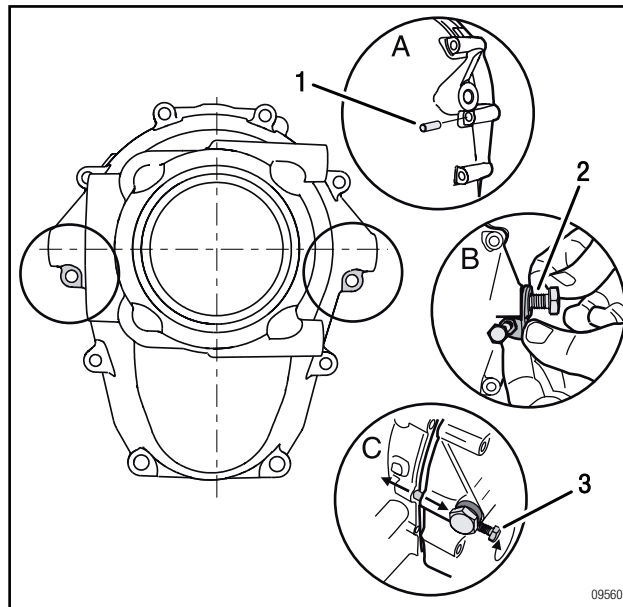

Figure 5.3

1 Dowel pin 8x20

2 Hex. screw M10x20

3 Hex. screw M6x40

BRP-Rotax
MAINTENANCE MANUAL LINE

DRIVE GEAR — REMOVAL

NOTICE	
The large and small gears are considered the same part (with the same part number and same serial number). They must not be mixed up with other gear sets.	

Step	Procedure
1	Lock the crankshaft into place. See Chapter 12-20-00.
2	Heat the hex. nut M30x1.5 with the hot air gun 100–120 °C (212–248 ° F).
3	Turn clockwise (left hand threads) to loosen hex. nut M30x1.5 with socket wrench SW 41 part no. 877445.

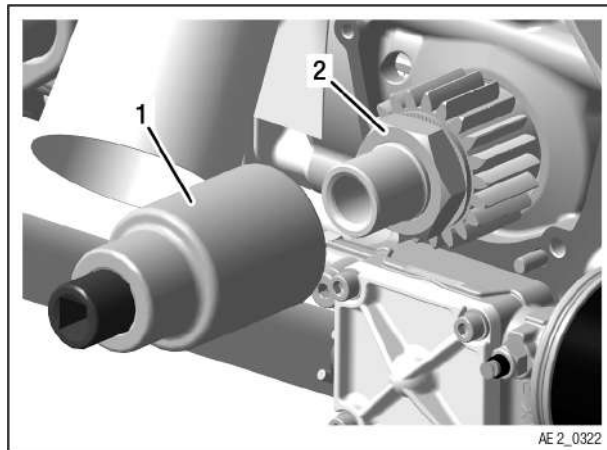

Figure 5.4

- 1 Socket wrench SW 41 part no. 877445 2 Hex. nut M30x1.5

Step	Procedure
4	Remove the drive gear and the friction washer from the crankshaft.

NOTE

If necessary, carefully lever off the drive gear with 2 screwdrivers.

NOTE

The gear set (large and small drive gear) are part of the gearbox assy. and both must be included if sending gearbox out for inspection or overhaul.

BRP-Rotax MAINTENANCE MANUAL LINE

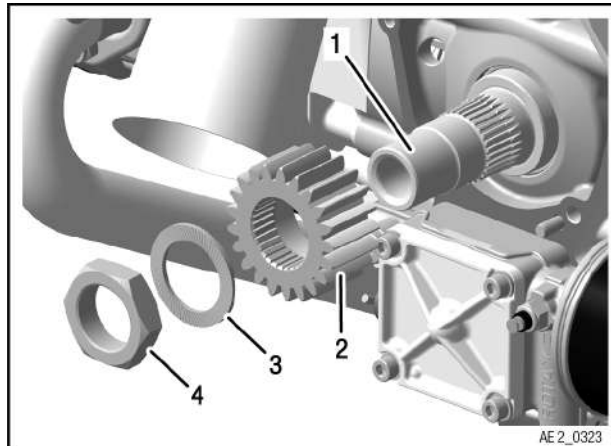

Figure 5.5

- | | |
|-------------------|--------------------|
| 1 Crankshaft | 2 Drive gear |
| 3 Friction washer | 4 Hex. nut M30x1.5 |

Make sure that both dowel sleeves remain in the crankcase and not in the gearbox housing.

PROPELLER STRIKE INSPECTION

General note

NOTICE

Damage to a propeller is serious and can cause the engine to be unairworthy.

After any propeller strike the following inspections must be performed before operation can continue. Some of the following inspections and procedures may require specialized tools and test equipment i.e. clutch disassembly and assembly by ROTAX® authorized overhaul facility.



See latest Maintenance Manual Heavy (MMH) for the respective engine type.

NOTE

See Service Letter SL-914-013 "Definition for propeller strike or accidental engine stoppage, current issue.

BRP-Rotax MAINTENANCE MANUAL LINE

Step	Procedure
1	Remove the propeller as per the airframe and propeller manufacturer's instructions.
2	Inspect the engine for damage. If any damage is detected, inspect, repair or overhaul the whole engine in accordance with the relevant Manual. Inspect all systems for correct function.
3	Inspect additional components like e.g. propeller governor, vacuum pump, external generator. Observe the manufacturer's instruction(s).



Observe all relevant directives from the aircraft manufacturer.

NOTE

Next steps need a valid iRMT training level for all tasks required by the Maintenance Manual Heavy (MMH).

Step	Procedure
1	Remove the gearbox assy. according to Chapter 05-50-00 section "Removal of the propeller gearbox".
2	Perform a crankshaft out-of roundness inspection on PTO side. See Chapter 72-10-00 Maintenance Manual Heavy (MMH).
3	Gearboxes with Genuine ROTAX® overload clutch installed: — Remove the drive gear from the crankshaft. See Chapter 05-50-00 section "Removal of the drive gear".
or 3	Gearboxes without Genuine ROTAX® overload clutch installed: — Perform a crankshaft distortion inspection. See Maintenance Manual Heavy (MMH) Chapter 72-00-00, continue as following: — Remove the drive gear from the crankshaft. See Chapter 05-50-00 section "Removal of the drive gear".

NOTE

Next steps need a valid iRMT training level for all tasks required by the Maintenance Manual Heavy (MMH).

Step	Procedure
1	These components need to be further inspected by authorized persons (iRMT Level minimum Heavy Maintenance).

BRP-Rotax MAINTENANCE MANUAL LINE

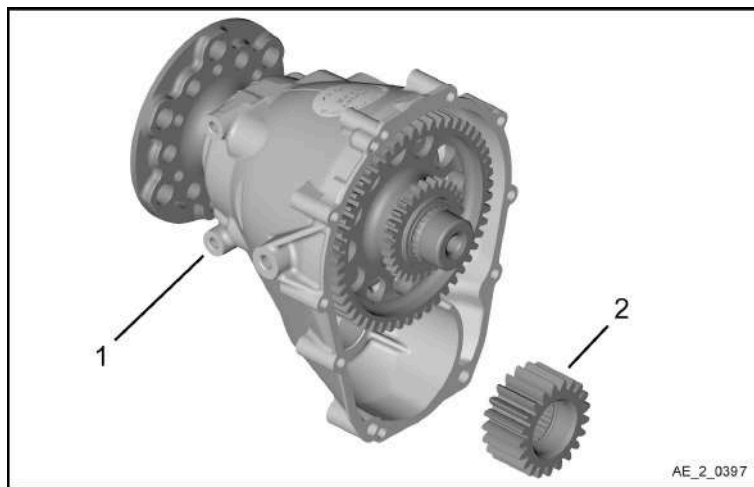

Figure 5.6: Components for inspection

1 Propeller gear assy.

2 Drive gear



See latest Illustrated Parts Catalog (IPC) for the respective engine type.

Step	Procedure
2	Inspect , repair or perform service of the whole gearbox in accordance with Chapter 72-10-00 of the latest Maintenance Manual Heavy (MMH).
3	Perform NDT inspection of the propeller shaft, dog hub, gear cover assy. and gear set.

BRP-Rotax
MAINTENANCE MANUAL LINE

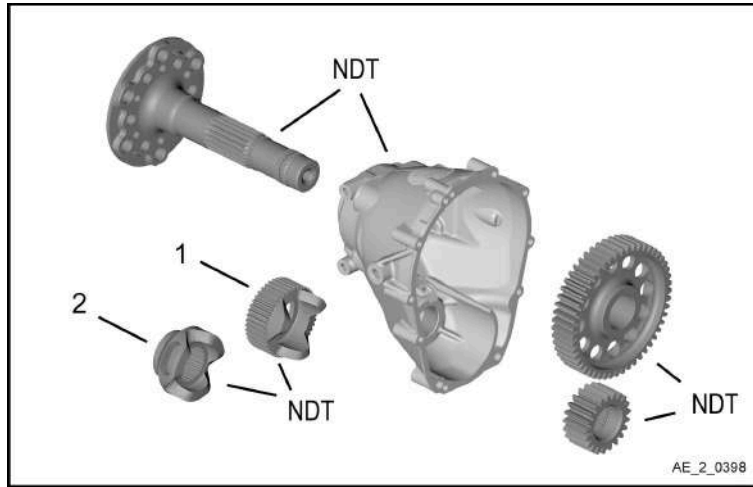

Figure 5.7: NDT inspection

1 Dog hub wide

2 Dog hub narrow

Step	Procedure
4	If cracks are detected on any these components the parts need to be replaced.

These parts need to be replaced 100% in course of a propeller strike inspection.

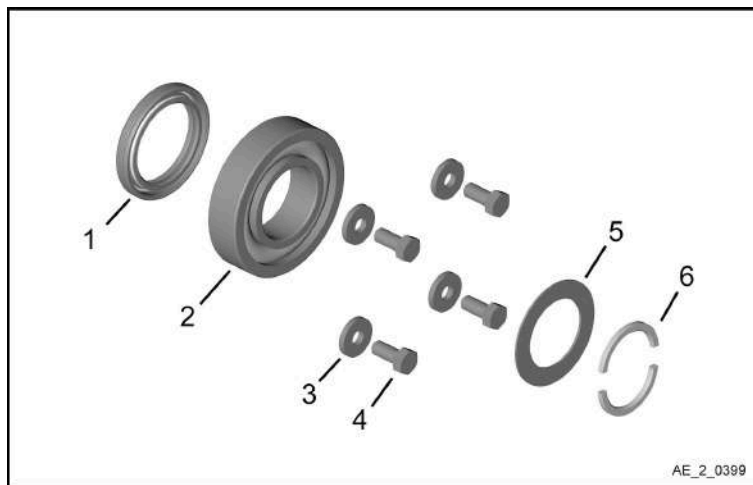

Figure 5.8: 100% replacement parts after propeller strike

1 Oil seal AS 40x55x7

2 Ball bearing 6207 TN6,35-72-17

3 Washer 7.2/18.8/3

4 Hex. screw M7x16

5 Shim

6 Ring half

BRP-Rotax
MAINTENANCE MANUAL LINE

Step	Procedure
5	Disassemble overload clutch. See Chapter 72-10-00 Maintenance Manual Heavy (MMH).
6	Check all given wear limits about the gearbox assy. See Chapter 72-10-00 Maintenance Manual Heavy (MMH) section "Inspection" and "Wear Limits".
7	If a part is not within given limits or has unusual wear or damage, the part needs to be replaced.

NOTICE
All gaskets, O-rings and oil seals must be replaced!

Step	Procedure
8	Assemble gearbox. See Chapter 72-10-00 Maintenance Manual Heavy (MMH) section "Assembly".

NOTE

Next steps need a valid iRMT training level for all tasks required by the Maintenance Manual Line (MML).

Step	Procedure
1	Re-install drive gear in accordance with Chapter 05-50-00 and check the crankshaft for out of roundness. See Chapter 72-10-00 Maintenance Manual Heavy (MMH).
2	For installation of the gearbox, see Chapter 05-50-00.
3	Perform an engine test run in accordance with Chapter 12-20-00.
4	Release the engine back to service and make an entry in the engine log-book detailing the work carried out.

BRP-Rotax
MAINTENANCE MANUAL LINE

INSTALLATION OF PROPELLER GEARBOX

Preparation

NOTICE

No hammering or pressing!
The drive gear must only be pushed on by hand.

NOTICE

Ensure that the friction washer is in the correct installation position.

NOTICE

The dog and drive gears are in pairs.
Only use parts with the same serial number.

- Clean and degrease all parts carefully
- Remove LOCTITE adhesive residue with LOCTITE 7063
- Visual inspection of the crankshaft on the power take off side
- Lock the crankshaft into place. See Chapter 12-20-00 section Locking/Loosen of the crankshaft

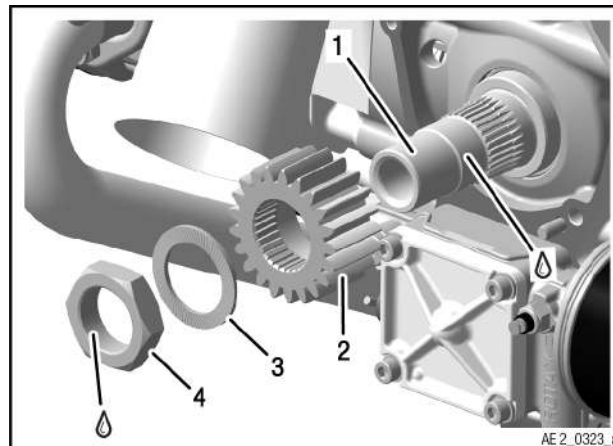

Figure 5.9

- | | |
|------------------------------------|-------------------|
| 1 Crankshaft (power take off side) | 2 Drive gear |
| 3 Friction washer VS-30 | 4 Hex. nut 30x1.5 |

Step	Procedure
1	Push the drive gear onto the crankshaft.

BRP-Rotax MAINTENANCE MANUAL LINE

NOTE

Due to limited tolerances, it may be difficult to push the drive gear onto the end of the crankshaft. If necessary, turn it and push it on in another position.

Step	Procedure
2	Secure the hex. nut M30x1.5 with LOCTITE 648 and screw it counter clockwise left hand threads onto the crankshaft along with the friction washer VS-30. Tightening torque 300 Nm (221 ft.lb.).

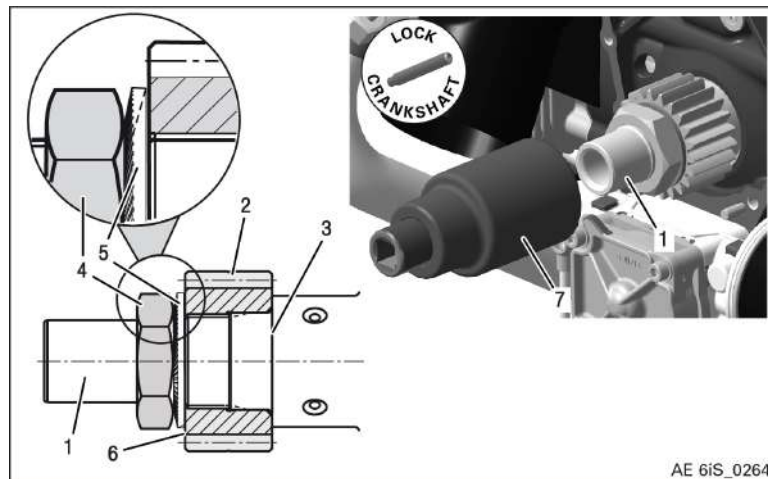

Figure 5.10

- | | |
|---------------------------------------|--------------------|
| 1 Crankshaft (power take off side) | 2 Drive gear |
| 3 Crankshaft | 4 Hex. nut M30x1.5 |
| 5 Friction washer VS-30 | 6 Serial number |
| 7 Socket wrench SW 41 part no. 877445 | |

NOTICE

The sealing surface must be free from dirt and oil.

Step	Procedure
3	Unlock the crankshaft. See Chapter 12-20-00 section
4	Inspect the run-out. See also Chapter 72-10-00 section Wear limits. (CS24)



See Maintenance Manual Heavy (MMH) for the engine type Chapter 72-10-00 section Wear limits (CS24).

BRP-Rotax MAINTENANCE MANUAL LINE

NOTE

If there is slight vertical run-out, replace the nut and repeat the measurement.

Step	Procedure
5	Insert 2 dowel pins 6x20 into the crankcase.
6	Apply engine assembly grease into the roller bearing and lubricate the crankshaft with a small amount of LOCTITE Anti Seize.

NOTE

Engines of the 914 Series configuration 2 have an oil seal.

- Grease oil seal for propeller shaft in crankcase.
- Lubricate bearing bore for propeller shaft in gearbox cover with engine oil
- Keep the rollers of the roller bearing in position with grease to facilitate assembly of propeller shaft.

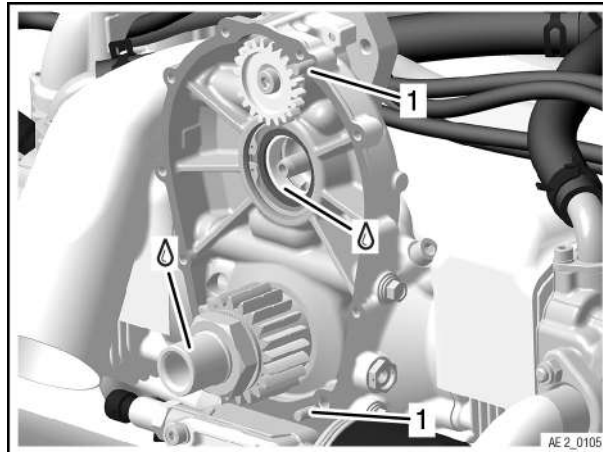

Figure 5.11

1 Dowel pins 6x20

BRP-Rotax
MAINTENANCE MANUAL LINE

NOTICE

The sealing surface must be free from dirt and oil.

Step	Procedure
7	Clean both sealing surfaces with LOCTITE 7063 or equivalent cleaner.
8	Apply a thin layer of LOCTITE 5910 surface sealing compound to the sealing surface of the gearbox housing.
9	Fit gearbox into position, carefully aligning crankshaft, dowels and gears.

NOTE

Move the propeller shaft a little to allow the drive gear to engage.

NOTICE

If excessive installation force is used, the bearing or governor/vacuum pump gear can be damaged

Step	Procedure
10	Tap gently on the gearbox housing with a soft-faced hammer to position the gearbox on the crankcase.

NOTE

If there is a large amount of resistance at a gap of approximately 10 mm, the bearing rollers of the roller bearing may not be in position.

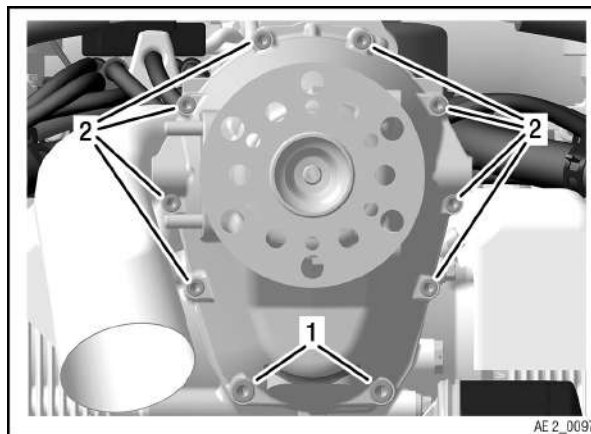

Figure 5.12: Screw position identification

1 Allen screw M8

2 Allen screw M6

BRP-Rotax
MAINTENANCE MANUAL LINE

Step	Procedure
11	Tighten 2 Allen screws M8x45 and 8 Allen screws M6x45 with washers 6.4 diagonally from each other. Tightening torque M6: 10 Nm (89 in.lb.). Tightening torque M8: 24 Nm (18 ft.lb.).

BRP-Rotax
MAINTENANCE MANUAL LINE

PROPELLER GEARBOX WITHOUT INTEGRATED OVERLOAD CLUTCH

General note After any propeller strike the following inspections must be performed before operation can continue.

1. Inspect the engine for damage. If any damage is detected, inspect, repair or overhaul the whole engine in accordance with the relevant Manual. Inspect all systems for correct functioning.
2. Inspect add-on components e.g. propeller governor, vacuum pump, external alternator. Observe the manufacturers instruction(s).
3. Observe all relevant directives from the aircraft manufacturer.
4. Remove the gearbox and replace the roller bearing in crankcase for propeller shaft. See Chapter 72-00-00 Maintenance Manual Heavy (MMH).
5. Remove the crankshaft gear for NDT inspection. See Chapter 72-00-00 Maintenance Manual Heavy (MMH).
6. Inspect, repair or overhaul of the whole gearbox in accordance with Chapter 72-00-00 Maintenance Manual Heavy (MMH). (For overhaul, send gearbox to a ROTAX® approved overhaul shop).
7. Perform NDT inspection upon housing and metal parts e.g. propeller shaft and gear set.
8. Re-install crankshaft gear and check the crankshaft for out-of roundness. See Chapter 72-00-00 Maintenance Manual Heavy (MMH).
9. Re-install the overhauled gearbox. See Chapter 72-00-00 Maintenance Manual Heavy (MMH).
10. Perform an engine test run in accordance with Chapter 12-20-00.
11. Release back to service and make a note in engine log book work carried out.

BRP-Rotax
MAINTENANCE MANUAL LINE

CHECKING OF THE OVERLOAD CLUTCH

General note

In the event of lead deposits and/or if slipping is suspected, it will be necessary to check the overload clutch.

NOTE

Slipping of overload clutch is apparent if at engine speed rise, the propeller speed does not increase at the same rate.

NOTE

The engine should be run for a short time (max. 1 day) prior to the test, otherwise there is the risk of the clutch "drying out", resulting in a higher torque.

Step	Procedure
1	Remove the propeller as per manufacturers instruction.
2	Lock the crankshaft. See Chapter 12-20-00 section Locking/loosen of the crankshaft.
3	Install a torque multiplier of respective specification (1000 Nm /737.6 ft.lb.) on the propeller flange. NOTE <i>Because of difficult measurement of the slipping torque the break-away torque is measured.</i>

NOTICE

Danger of damage to the engine suspension!

Depending on the engine installation (e.g. in the case of extremely lightweight engine suspension), the gearbox must be removed and the test carried out on a suitable mounting attachment.

BRP-Rotax MAINTENANCE MANUAL LINE

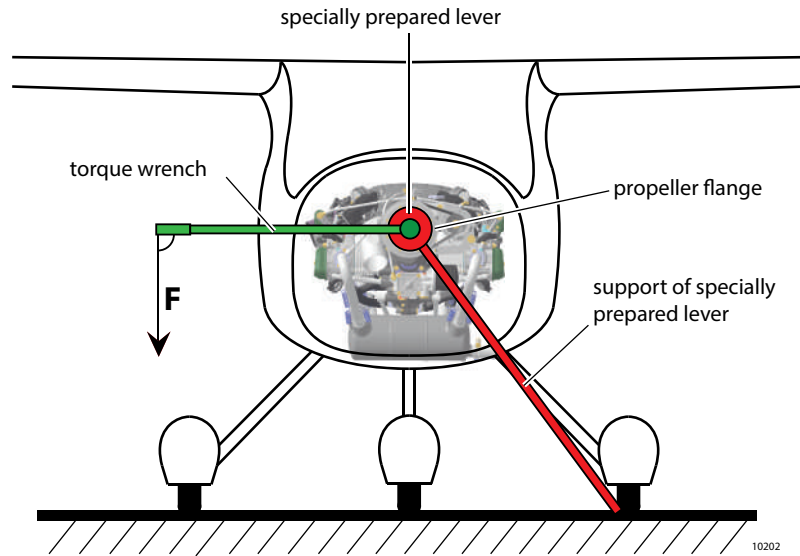

Figure 5.13: Front view TYPICAL

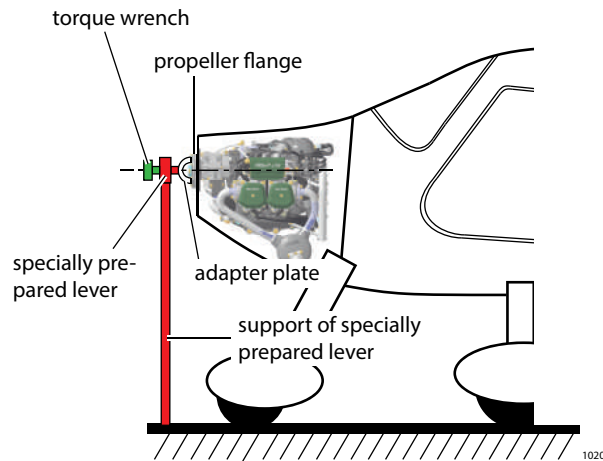

Figure 5.14: Side view TYPICAL

Step	Procedure
4	<p>Attach and adjust outrigger of the torque multiplier. If the engine is mounted in an aircraft, this one must be supported/fixed to the ground.</p> <p>NOTE</p> <p><i>The effective direction of the support device is opposite to the input direction of rotation.</i></p>
5	Connect torque wrench to torque multiplier.
6	Turn over the clutch for 3 times.

BRP-Rotax
MAINTENANCE MANUAL LINE

Step	Procedure
7	Inspect the breakaway torque with a torque wrench. NOTE <i>Check reduction ratio of the torque multiplier. The measurement must be repeated a few times (min. 2x) in order to obtain a stable value.</i>
8	Compare the measured value with the limits. If the value is greater or smaller than the limit values, the overload clutch must be inspected, repaired or overhauled in accordance with the BRP-Rotax instructions for continued airworthiness.

Breakaway torque		
Engine type	minimum Limit	maximum Limit
914	600 Nm (442 ft.lb)	800 Nm (590 ft.lb.)

NOTICE
<p>Possible damage to the gearbox and slipping of the overload clutch. The maximum limit must not be exceeded. Values below the minimum limit may cause a slipping of the overload clutch that result in an overspeed.</p>

Step	Procedure
9	Remove torque multiplier and torque wrench.
10	Release the crankshaft. See Chapter 12-20-00 section Locking/loosen of the crankshaft.
11	Install the propeller according to the manufacturers instruction.

BRP-Rotax
MAINTENANCE MANUAL LINE

EXAMINATION AFTER ENGINE FAILURE

General note

In order to find possible causes of the failure, it is important to pass on all available data. Observations on the aircraft and the engine suspension can also be of help. It is important to pay particular attention to any of the following engine phenomena to facilitate troubleshooting.

Engine

Engine runs erratically and misfires	
part	possible cause
Fuel system	fuel supply vapour locks contamination float chamber venting air intake leakage carburetor icing
Ignition system (Ignition switch wire /MAG switch), Ignition module, wiring connectors, charging coil, ignition switch. Spark plug, wire and socket	malfunction grounding defect wrong spark plug connection loose connection

Rough running engine

Rough running engine	
part	possible cause
Ignition	wiring (assignment fault)
Engine	engine temperature too low wrong intake air
Carburetor	fuel supply contamination in float chamber or float needle valve float chamber venting air intake leakage incorrect synchronization of the carburetor

Engine stoppage

NOTICE
Should one of the above mentioned items occur even for a short time then a detailed check of the engine is necessary. The fault needs to be located and corrected.

BRP-Rotax
MAINTENANCE MANUAL LINE

Unintended engine stoppage by seizing	
part	possible cause
Oil system	oil pressure too low or no oil pressure oil shortage contamination plugged / restricted venting of oil tank
Oil pump	damaged rotors or drive pin
Camshaft bearings/Conrod bearings	damage and wear (low oil pressure)

NOTICE
The entire assembly must be dismantled, inspected and repaired.

- The whole engine must be inspected, repaired or overhauled in accordance with the BRP-Rotax instructions for continued airworthiness.
- Inspect all systems for correct functioning.
- Detailed inspection of affected engine components.

Cylinder head

A rise in cylinder head temperature above normal operating limits (see Operators Manual (OM)) is a clear signal for a failure in the cooling system.

Cylinder head temperature or coolant temperature too high	
part	possible cause
Cooling system	not enough coolant insufficient venting and/or overflow tank restrictions
Return valve, pressure relief valve in cap	malfunction
Radiator	contaminated sealing of radiator to cowling poor cooling flow
Radiator cap	leaking
Water pump	contamination, malfunction, leakage bore

BRP-Rotax
MAINTENANCE MANUAL LINE

RETURNING ENGINE TO SERVICE AFTER SUBMERGING IN WATER

General note

NOTICE

The engine must be marked clearly “Engine submerged in water“. Define if it was fresh water or salt water.

An engine which has been submerged in water must be inspected, repaired or overhauled in accordance with the BRP-Rotax instructions for continued airworthiness. See current Maintenance Manual of the respective engine type.

Inspection

- Inspect all systems for correct functioning.

NOTE

Prior to the detailed inspection, all parts should be cleaned and inspected for corrosion. For accessories (e.g. vacuum pump, fuel filter etc.) the instructions and specifications of the corresponding manufacturer must be followed.

Complete inspection of these components:

- | | |
|---------------------------|----------------------|
| • power supply | • cooling system |
| • gearbox | • valve train system |
| • engine suspension frame | • exhaust system |
| • fuel system | • lubrication system |
| • cylinder unit | • start system |

In most cases an overhaul is necessary, in this regard the engine has to be overhauled according to the current Overhaul Manual (OHM) for the respective engine type. Overhaul Manual (OHM) and its appendix is available for any appropriately rated person or entity on request and by following the standards of the original manufacturer.

If an engine was submerged into water, all electrical components (e. g.: electric fuel pumps, ignition coils, stators, spark plugs, spark plug connectors, FUSE BOX, sensors, ECU, wiring harness) must be replaced.

NOTE

Discoloration or corrosion are signs of submerging in water.

In most cases an overhaul is necessary, in this regard the engine has to be overhauled according to the current Overhaul Manual (OHM) for the respective engine type. Overhaul Manual (OHM) and its appendix is available for any appropriately rated person or entity on request and by following the standards of the original manufacturer.

BRP-Rotax
MAINTENANCE MANUAL LINE

If an engine was submerged into water, all electrical components (e. g.: electric fuel pumps, ignition coils, stators, spark plugs, spark plug connectors, FUSE BOX, sensors, ECU, wiring harness) must be replaced.

NOTE

Discoloration or corrosion are signs of submerging in water.

BRP-Rotax
MAINTENANCE MANUAL LINE

INSPECTION IN EXTREME CLIMATIC CONDITIONS

General note

NOTICE

Every 25 hr. checks of air filter, coolant radiator and oil cooler are necessary.

Flying in deserts or areas with heavily contaminated or dusty air causes increased wear on all components. For this reason, shorter maintenance intervals are recommended.

Flying in areas with extreme climatic conditions or in extreme altitudes requires adjustment of the carburetor jetting and of the cooling system. To do this, it is necessary to contact the aircraft manufacturer and ROTAX® Authorized Distributor or their independent Service Center.

RETURNING ENGINE TO SERVICE AFTER INFLUENCE BY FIRE

General note An engine after influence by fire must be inspected, repaired or overhauled according to the BRP-Rotax instructions for continued airworthiness.

Inspection • Inspect all systems for correct functioning.

NOTE

Prior to the detailed inspection, all parts should be cleaned and inspected for burn penetration or melted materials.

If an engine was influenced by fire, first a visual inspection of all parts has to be done and then a hardness test of all mechanical parts must be performed (e. g.: crankcase, cylinder, cylinder heads etc.).

EXCEEDING OF MAX. ADMISSIBLE ENGINE RPM

General note

NOTICE

Any exceeding of the max. admissible engine RPM must be entered by the pilot into the engine log book stating duration extent of overspeeding and pertinent detail.

5800 rpm up to max. 6200 rpm

If the limit was exceeded for max. 1 minute up to 6200 rpm

Step	Procedure
1	No action is required.

BRP-Rotax MAINTENANCE MANUAL LINE

**5800 rpm up to
max. 6200 rpm**

If the limit was exceeded for more than 1 minute up to 6200 rpm.

Step	Procedure
1	Check that the push-rods are straight. See Chapter 72- 00-00 of the latest Maintenance Manual Heavy (MMH).

**6200 rpm up to
max. 6500 rpm**

If the limit was exceeded for max. 1 minute up to 6500 rpm.

Step	Procedure
1	Check that the push-rods are straight.

**6200 rpm up to
max. 6500 rpm**

If the limit was exceeded for more than 1 minute up to 6500 rpm.

Step	Procedure
1	The whole engine must be inspected, repaired or overhauled in accordance with the BRP-Rotax instructions for continued airworthiness.
2	Check that the push-rods are straight.
3	Inspect the crankshaft for out-of-roundness and distortion. See Chapter 72-00-00 of the latest Maintenance Manual Heavy (MMH).
4	Inspect all systems for correct functioning.
5	Detailed inspection of affected engine components.

**more than 6500
rpm**

If the speed of 6500 rpm was exceeded.

Step	Procedure
1	The whole engine must be inspected, repaired or overhauled in accordance with the BRP-Rotax instructions for continued airworthiness.
2	Check cylinder differential pressure.
3	Check that the push-rods are straight.
4	Check if piston had contact with valve.
5	Check for out of roundness of valves.
6	Replace the crankshaft. The crankshaft has to be inspected in according to the current Overhaul Manual (OHM) for the respective engine type. Overhaul Manual (OHM) and its appendix is available for any appropriately rated person or entity on request and by following the standards of the original manufacturer.

BRP-Rotax
MAINTENANCE MANUAL LINE

Step	Procedure
7	Inspect all systems for correct functioning.
8	Detailed inspection of affected engine components.

EXCEEDING OF MAX. COOLING SYSTEM TEMPERATURE

General note See SB-914-049, latest issue.

NOTICE
<p>If the maximum cooling system temperature is exceeded, other limits are also often exceeded, e.g. oil temperature. Please observe the relevant instructions.</p>

NOTE

Any exceeding of the max. admissible cooling system temperature must be entered by the pilot into the engine log book, stating duration, extent of excess temperature and pertinent detail.

Exceeding of max. cylinder head temperature

All engines affected with serial number without Suffix -01.

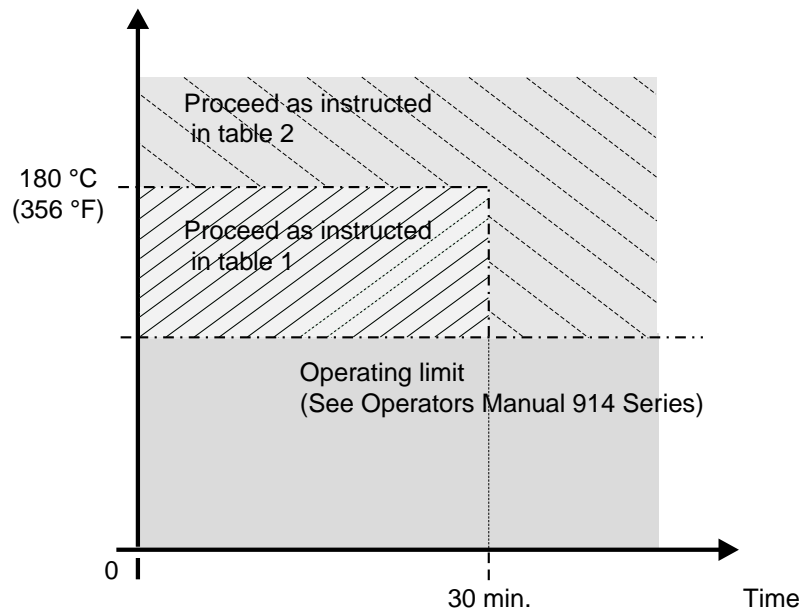

Figure 5.15: Cylinder head temperature overview and proceed:

BRP-Rotax
MAINTENANCE MANUAL LINE

Exceeding up to 180 °C (356 °F) cylinder head temperature

Table 1: Temperature exceeded less than 30 min.	
Step	Procedure
1	The whole cooling system must be inspected, repaired or overhauled in accordance with the BRP-Rotax instructions for continued airworthiness.
2	Inspect all further systems for correct functioning.
3	Carry out detailed inspection of the affected engine components such as: <ul style="list-style-type: none"> • Leakage check on the cooling system. • Check that the cylinder head attachment is fitted securely. If any of the cylinder head nuts are loose, proceed as instructed in Table 2. "Temperature exceeded 180 °C (356 °F) and/or the operating limit for longer than 30 min." • Check all coolant fittings (feed/outflow) for secure fit.

Exceeding over 180 °C (356 °F) cylinder head temperature

Table 2: Temperature exceeded 180 °C (356 °F) and/or the operating limit for longer than 30 min.	
Step	Procedure
1	The whole cooling system must be inspected, repaired or overhauled in accordance with the BRP-Rotax instructions for continued airworthiness.
2	Inspect all further systems for correct functioning.
3	Carry out detailed inspection of the affected engine components such as.
4	Check compression by carrying out a differential pressure check.
5	All cylinder heads and cylinders must be removed and subjected to a detailed check including hardness testing. See Chapter 72-00-00 in the Maintenance Manual Heavy (MMH).

BRP-Rotax MAINTENANCE MANUAL LINE

Exceeding of max. coolant temperature

All engines affected with serial number with Suffix -01.

General note

See SB-914-049, latest issue.

NOTICE

If the maximum coolant temperature is exceeded, other limits are also often exceeded, e.g. oil temperature. Please observe the relevant instructions.

NOTE

Any exceeding of the max. admissible coolant temperature must be entered by the pilot into the engine log book, stating duration, extent of excess temperature and pertinent detail.

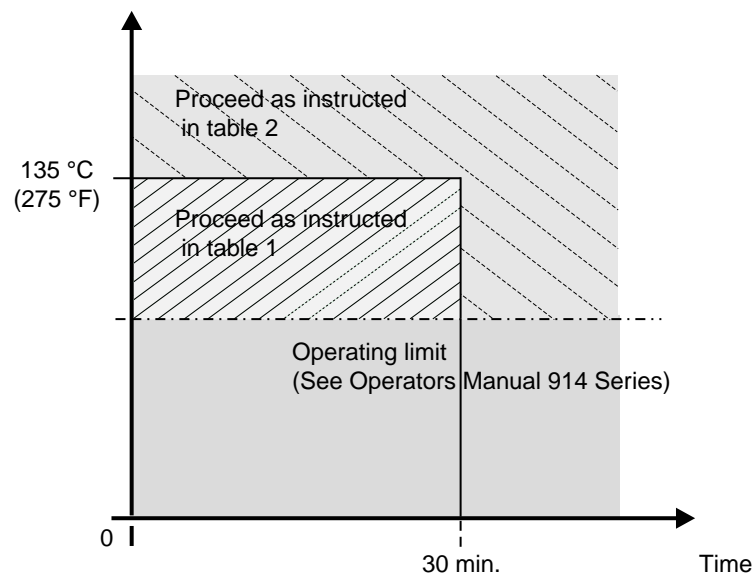

Figure 5.16: Coolant temperature overview and proceed:

BRP-Rotax
MAINTENANCE MANUAL LINE

Exceeding up to 135 °C (275 °F) cooling temperature

Table 1: Temperature exceeded less then 30 min.	
Step	Procedure
1	The whole cooling system must be inspected, repaired or overhauled in accordance with the BRP-Rotax instructions for continued airworthiness.
2	Inspect all further systems for correct functioning.
3	Carry out detailed inspection of the affected engine components such as: <ul style="list-style-type: none"> • Leakage check on the cooling system. • Check that the cylinder head attachment is fitted securely. If any of the cylinder head nuts are loose, proceed as instructed in sec. "Temperature exceeded 135 °C (275 °F) and/or the operating limit for longer than 30 min." • Check all coolant fittings (feed/outflow) for secure fit.

Exceeding over 135 °C (275 °F) cooling temperature

Table 2: Temperature exceeded 135 °C (275 °F) and/or the operating limit for longer than 30 min.	
Step	Procedure
1	The whole cooling system must be inspected, repaired or overhauled in accordance with the BRP-Rotax instructions for continued airworthiness.
2	Inspect all further systems for correct functioning.
3	Carry out detailed inspection of the affected engine components.
4	Check compression by carrying out a differential pressure check.
5	All cylinder heads and cylinders must be removed and subjected to a detailed check including hardness testing. See Chapter 72-00-00 of the Maintenance Manual Heavy (MMH).

BRP-Rotax
MAINTENANCE MANUAL LINE

NON COMPLIANCE WITH THE COOLANT SPECIFICATION

General note

NOTICE	
Use only coolant as recommended in the current Operators Manual (OM)	
Non compliance with the coolant specification	
Step	Procedure
1	When a different coolant than the former one (conventional coolant) used, then the coolant system has to be flushed. See Chapter 12-20-00 section Flushing the cooling system .
2	Fill expansion tank with new coolant (highest point of the coolant system). See Chapter 12-10-00 section Coolant check/replenish .
3	Re-install the radiator cap.
4	NOTE <i>Run engine for a minute and replenish as required.</i>

BRP-Rotax
MAINTENANCE MANUAL LINE

EXCEEDING THE MAX. PERMISSIBLE OIL TEMPERATURE

General note

NOTICE

If the max. permissible oil temperature is exceeded, other limits are often exceeded, too, e.g. the cylinder head temperature and coolant temperature. Please observe the relevant instructions.

NOTE

Any exceeding of the max. admissible oil temperature must be entered by the pilot into the engine log book, stating duration and extent of excessive temperature and pertinent detail.

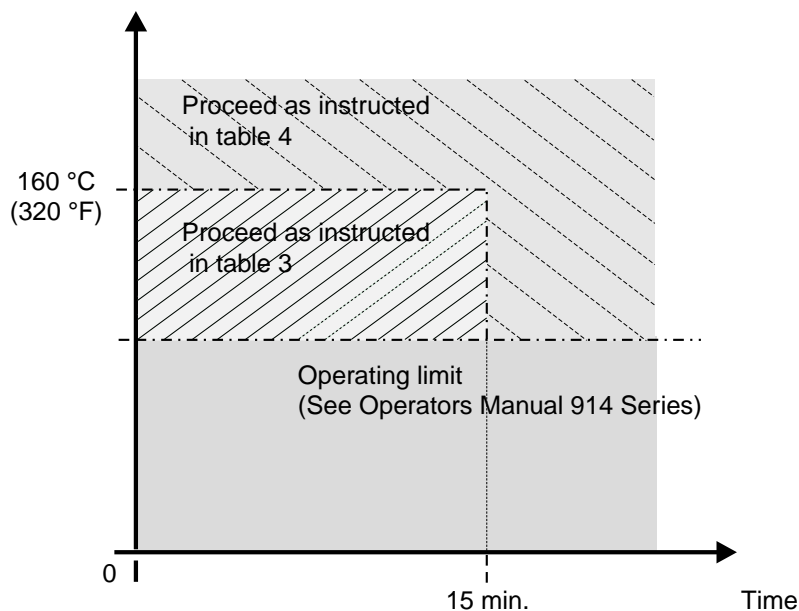

Figure 5.17: Overview and proceed

Exceeding up to max. 160 °C (320 °F)

Table 3: Excess temperature up to max. 160 °C (320 °F) max. 15 min.	
Step	Procedure
1	The whole oil system must be inspected, repaired or overhauled in accordance with the BRP-Rotax instructions for continued airworthiness.
2	Inspect oil level in the oil tank.
3	Inspect oil cooler for contamination and check the entire oil circuit for correct functioning.

BRP-Rotax
MAINTENANCE MANUAL LINE

Table 3: Excess temperature up to max. 160 °C (320 °F) max. 15 min.	
Step	Procedure
4	Check that oil lines are routed correctly and undamaged.
5	Cut oil filter housing and inspect filter mat for foreign matter.
6	Carry out oil change.
7	Inspect all further systems for correct functioning.

Exceeding over 160 °C (320 °F)

Table 4: Excess temperature over 160 °C (320 °F) and/or the operating limit for longer than 15 min.	
Step	Procedure
1	The whole oil system must be inspected, repaired or overhauled in accordance with the BRP-Rotax instructions for continued airworthiness.
2	Inspect all further systems for correct functioning.
3	Carry out detailed inspection of the affected engine components.
4	The whole oil system (oil cooler, oil lines) must be inspected.
5	Cut oil filter housing and inspect filter mat for foreign matter.
6	Carry out oil change.

OIL PRESSURE BELOW MINIMUM VALUE

General note

NOTICE

If the oil pressure falls below the minimum value, other limits are often exceeded, e.g. the oil temperature. Please observe the relevant instructions.

NOTE

Any exceeding of the min. admissible oil pressure must be entered by the pilot into the engine log book, stating duration and extent of excessive pressure and pertinent details.

BRP-Rotax MAINTENANCE MANUAL LINE

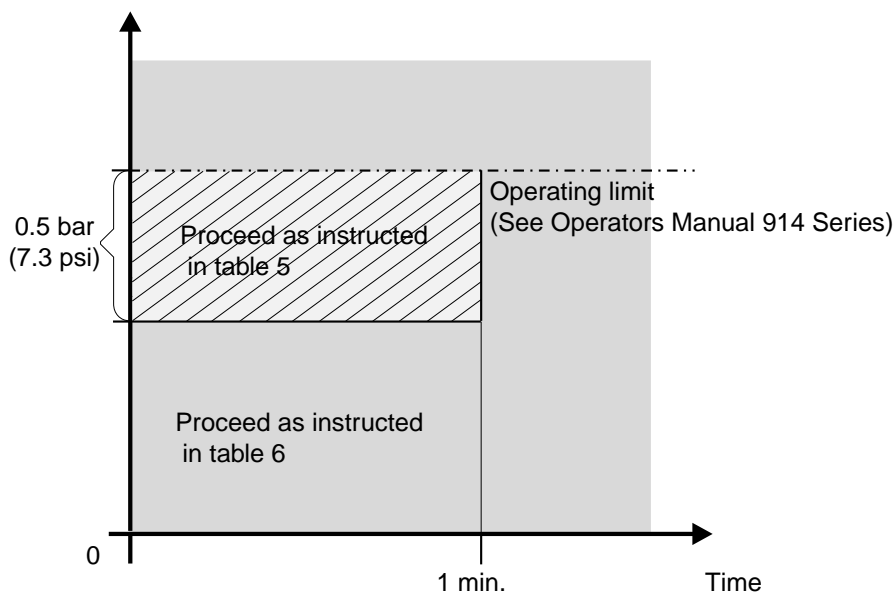

Figure 5.18: Overview and instruction

Oil pressure below minimum oil pressure on the ground

If noticed **on ground**, immediately stop the engine and determine the cause.

- Inspect the complete lubrication system, trace cause and rectify.



See Service Instruction SI-914-007, latest issue.

If the oil pressure falls below the minimum value up to max. 0.5 bar (7.25 psi) and for max. 1 min., the cause must be determined.

Table 5: Oil pressure below minimum permissible oil pressure up to max. 0.5 bar (7.25 psi) max. 1 min. in flight	
Step	Procedure
1	Inspect all oil lines for restrictions and clear passage.
2	Verify oil quantity.
3	Inspect pressure sensor and connector.
4	Inspect indicating instrument to specifications of the manufacturer, replace as required.
5	Inspect crankcase pressure (See Installation Manual (IM), latest issue.).
6	If no cause for the low oil pressure is found after the above checks, carry out an oil change.

BRP-Rotax
MAINTENANCE MANUAL LINE

Table 5: Oil pressure below minimum permissible oil pressure up to max. 0.5 bar (7.25 psi) max. 1 min. in flight	
Step	Procedure
7	If after the previous checks and oil change the oil pressure is still too low, repair or overhaul the engine in accordance with the BRP-Rotax instructions for continued airworthiness.
8	Inspect all systems for correct functioning.
9	Carry out detailed inspection of the affected engine components.

NOTICE
Replace the oil cooler and oil lines. Before the re-installation of the engine the complete lubrication system (inclusive oil tank) must be flushed.

Minimum oil pressure in flight lower than 0.5 bar (7.25 psi).

Consequent damage can be expected if the oil pressure falls below the minimum value by more than 0.5 bar (7.25 psi). See current Operators Manual (OM).

Table 6: Oil pressure below minimum permissible value more than 0.5 bar (7.25 psi) in flight	
Step	Procedure
1	The whole oil system must be inspected, repaired or overhauled in accordance with the BRP-Rotax instructions for continued airworthiness. <ul style="list-style-type: none"> • The crankshaft must be replaced.
2	Carry out detailed inspection of the affected engine components.
3	Cut oil filter housing and inspect filter mat for foreign matter.
4	Inspect all further systems for correct functioning.

BRP-Rotax MAINTENANCE MANUAL LINE

OIL SPECIFICATION NOT RESPECTED

General note **NOTE**

An entry by the pilot in the engine log book of all pertinent details is required.

If by error engine was serviced with oil, which does not correspond with oil specification in the Operators Manual and the engine has been in operation for **less than 5 hours**, the following measures must be taken:

Less than 5 hr.

Oil specification not respected	
Step	Procedure
1	Carry out an oil change.
2	Remove the lowest positioned screw (banjo bolt, plug screw or screw socket) and drain the remaining oil from the crankcase. Re-install banjo bolt or plug screw.  Tightening torque see Installation Manual (IM) I for the respective engine type.
3	Replace oil filter.
4	Drain oil completely from oil cooler and oil hoses.
5	Drain oil from oil tank.
6	Refill oil tank with oil as specified, refer to Operators Manual (OM).
7	Purge air from oil system. See Chapter 12-20-00 section Purging the oil system .
8	Run engine for approx. 1 hour and change oil and oil filter once more, see Chapter 12-20-00 section Oil change.

BRP-Rotax
MAINTENANCE MANUAL LINE

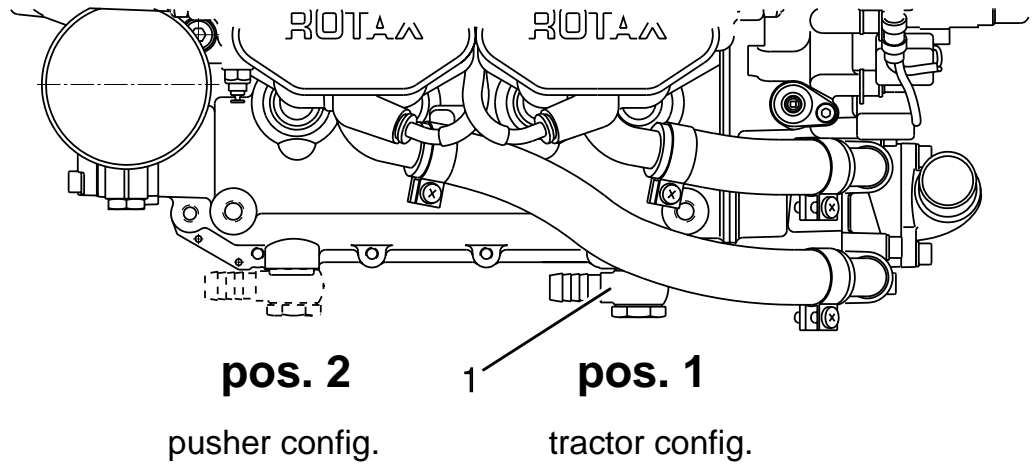

AE_912_0093

Figure 5.19: Connections

1 Banjo bolt

Longer than 5 hr. If the engine has been operated **longer than 5 hours** with engine oil not corresponding with specification in the Operators Manual (OM) the following work is required.

Oil specification not respected	
Step	Procedure
1	Remove propeller gearbox.
2	The gearbox must be inspected, repaired or overhauled in accordance with the BRP-Rotax instructions for continued airworthiness.
3	Carry out detailed inspection of the affected engine components.
4	Carry out an oil change.
5	Remove the lowest positioned banjo screw (banjo bolt, plug screw or screw socket) and drain the remaining oil from the crankcase. Re-install banjo bolt or plug screw.  Tightening torque see Installation Manual (IM) for the respective engine type.
6	Replace oil filter.
7	Inspect the contact surfaces camshaft / hydraulic valve tappet.
8	Drain oil completely from oil cooler and oil hoses.
9	Drain oil from oil tank.
10	Refill oil tank with oil as specified, refer to Operators Manual (OM) .

BRP-Rotax
MAINTENANCE MANUAL LINE

Oil specification not respected	
Step	Procedure
11	Purge air from oil system. See Chapter 12-20-00 section Purging the oil system.
12	Run engine for approx. 1 hour and change oil and oil filter once more, as stated above.

SPARK PLUG NOT IN ACCORDANCE WITH SPECIFICATION

General note

If by error any of the spark plugs were installed which are not according to specification of the engine manufacturer and/or not genuine ROTAX® parts, the following verification will be necessary.

Spark plug not in accordance with specification	
Step	Procedure
1	Mark position of the spark plugs (e.g. cylinder 1 top) and remove all spark plugs.
2	Inspect the spark plugs for damage (formation of melt beads, burn off). At heavy melt beads or bad burn off, inspect the piston dome and cylinder wall by borescope. If parts are damaged, the engine must be inspected, repaired or overhauled in accordance with the BRP-Rotax instructions for continued airworthiness.
3	Inspect all systems for correct function.
4	Detailed inspection of affected engine components.
5	Inspect spark plug thread for damage (especially at bad burn off).
6	Differential pressure check. See Chapter 12-20-00 section Checking the compression.
7	Change oil and oil filter.

BRP-Rotax
MAINTENANCE MANUAL LINE

NON COMPLIANCE OF FUEL QUALITY

General note With the use of unsuitable fuel quality (e.g. low octane fuel), depending on the operating condition the knock control would activate itself. This control should prevent damage by knocking combustion.

The use of unsuitable fuel quality has to be entered in the engine log book.

Independent of subsequent following inspections are required:

Non compliance with fuel quality	
Step	Procedure
1	Visual inspection of engine.
2	Empty the fuel system according to the instructions of aircraft manufacturer.
3	Flush fuel system.
4	Replace fuel filter
5	Check differential pressure.
6	Engine test run.

BRP-Rotax
MAINTENANCE MANUAL LINE

CHECKING OF THE COOLING SYSTEM / RADIATOR CAP

General

Cooling system / radiator cap. check in case of unusual leakage and deposits or exceeding of max. cooling system temperature.

⚠ WARNING

Risk of burns and scalds. Hot engine parts.

Always allow engine to cool down to ambient temperature before starting work.

⚠ WARNING

Risk of Burns!

Never open the radiator cap when the cooling system is hot. For safety's sake, cover cap with a rag and open slowly. Sudden opening of the cap could provoke the escape of boiling coolant and result in scalding.

ENVIRONMENTAL NOTE

Protect the environment.

Do not harm the environment by spilling coolant. Dispose of coolant in an environmentally friendly manner.

Special tool

NOTE

Use suitable manual pump with manometer or pressurized-air hose with suitable pressure reduction valve for testing.

BRP-Rotax MAINTENANCE MANUAL LINE



Figure 5.20: Special tool

Instruction

NOTE

Perform a visual check of the entire cooling system, check for chafing and coolant residue.

Step	Procedure
1	<p>Remove one coolant hose at the upper outlet elbow on the cylinder head, hold the hose up and drain the hose and expansion tank.</p> <p>NOTE</p> <p><i>It is important to have a container of adequate size ready to capture the coolant before removing the hose.</i></p>

BRP-Rotax
MAINTENANCE MANUAL LINE

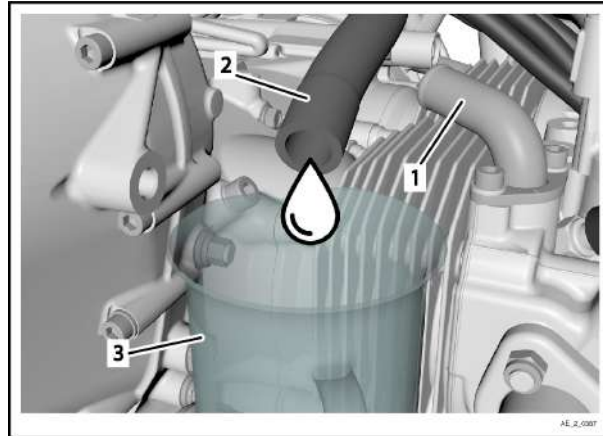

Figure 5.21: TYPICAL

- 1 Coolant outlet elbow
- 2 Upper coolant hose
- 3 Clean container

Step	Procedure
2	<p>Seal the open elbow side with a temporary piece of coolant hose, with a plug inserted in the open end. The plug needs to hold a pressure of 2 bar (29 psi).</p> <p>NOTE</p> <p><i>Use standard coolant water hose part no. 922250 and self compensating clamp 25 part no. 851645 to secure. Plug diameter 12 -13 mm (0.473 in. - .0.512 in.).</i></p>

BRP-Rotax
MAINTENANCE MANUAL LINE

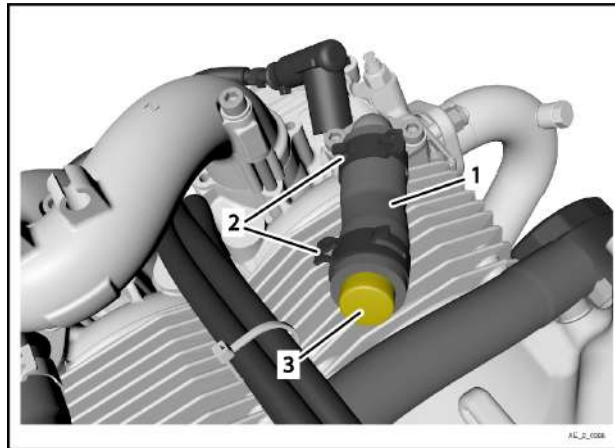

Figure 5.22: TYPICAL

1 water hose part no. 922250

2 Self compensating clamp 25 part no. 851645

3 Plug

Step	Procedure
3	To the open coolant hose, attach an adapter and connect to a manual pump or pressure reduction valve. Use the standard spring clamp to secure the hose on the adapter.

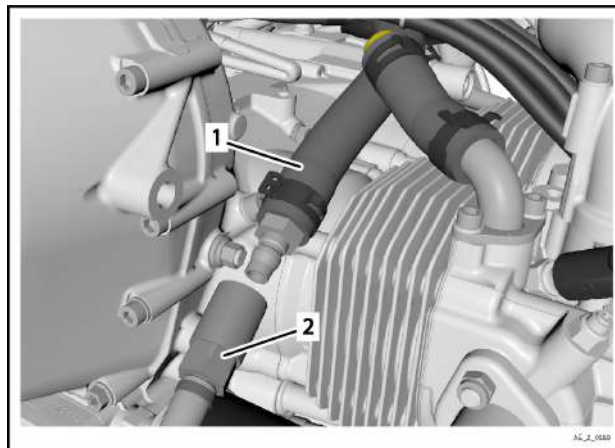

Figure 5.23: TYPICAL

1 Hose to expansion tank

2 To pressure source

BRP-Rotax MAINTENANCE MANUAL LINE

Step	Procedure
4	Remove the connection hose from expansion tank to overflow bottle and install a temporary clear hose.
5	Refill the cooling system at the expansion tank and overflow bottle to standard levels.
6	Apply small amount of coolant to rubber surfaces inside cap (provides lubrication to prevent binding). Tighten the radiator cap by hand. NOTE <i>The radiator cap must be tightened until the stop lug is contacted</i>

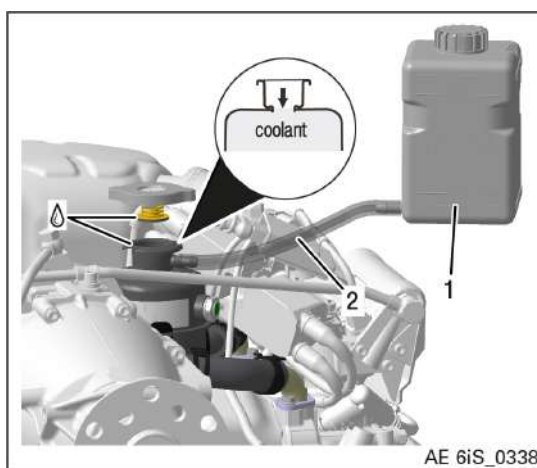

Figure 5.24

1 Overflow bottle

2 Temporary clear hose

Step	Procedure
7	Turn the propeller slowly by hand in the normal direction of rotation several times. Check cooling liquid level again, if necessary replenish.
8	Pressurize the expansion tank up to relief pressure of the cap, indicated by rising bubbles in the clear hose.

NOTICE

Do not relieve pressure via opening the radiator cap. Use pressure relief unit on pump.

BRP-Rotax MAINTENANCE MANUAL LINE

NOTICE

Use only coolant as recommended in the current Operators Manual (OM).

Step	Procedure
9	Check if the relief pressure lies within following limits for both radiator cap types. <ul style="list-style-type: none"> Min. relief pressure: 1.2 bar (17.4 psi) Max. relief pressure: 1.6 bar (23.2 psi)
10	If relief pressure is higher than the max. or lower than the min. relief pressure, replace the radiator cap with new and repeat the test.
11	If min. pressure cannot be achieved, or pressure cannot be maintained - check the system to find the leakage.

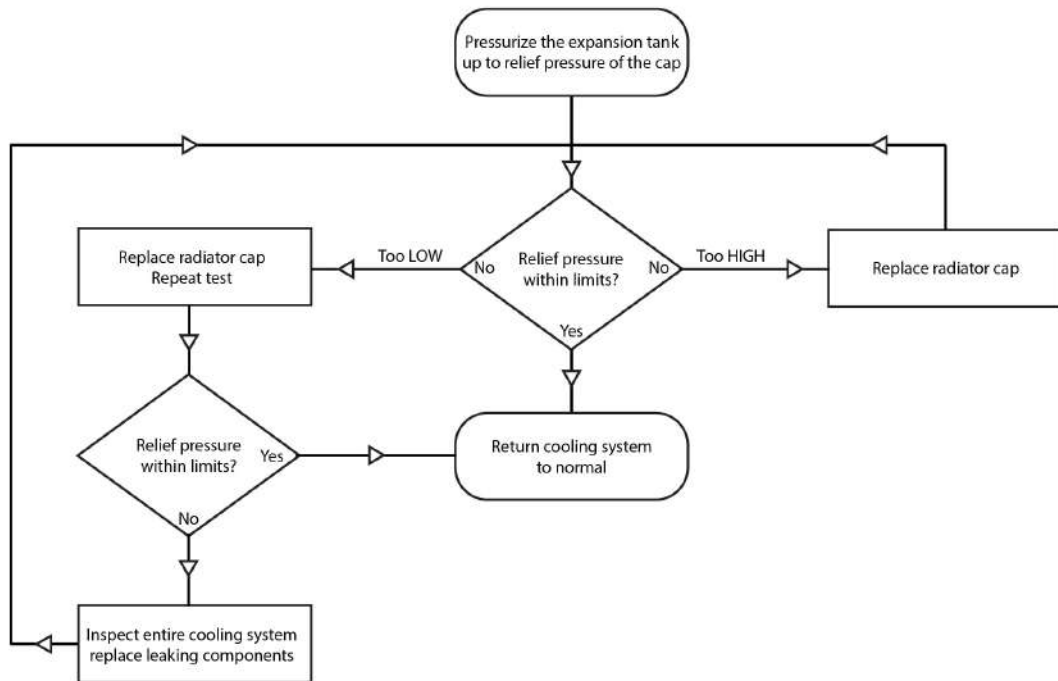

AE_2_0091

Figure 5.25

⚠ WARNING

Non-compliance can result in serious injuries or death!
For static, on-ground testing of the coolant system only. Do not run the engine while configured for pressure testing.

BRP-Rotax

MAINTENANCE MANUAL LINE

NOTE

To make the entire cooling system check easier, the coolant may be entirely drained, and the system pressurized with air only, up to 1.6 bar (23.2 psi.). Check can be performed with leak detection fluid to locate the leakage.

After replacing any part of cooling system perform cooling system check again to make sure the system works correctly.

Return coolant system to normal operating configuration.

Engine test run Engine test run is necessary:

Step	Procedure
1	Operate the engine until temperatures have stabilized for a period of 5 minute (engine oil temperature between 50 to 70 °C (122 to 160 °F).
2	Switch the engine "OFF".
3	Allow the engine to cool down.
4	Check for leaks.
5	Check the coolant level and top up with coolant as required.

SMOOTH PERFORMANCE OF THE ENGINE

General note

⚠ WARNING

Risk of electric shock!

Ignition "OFF" and system grounded! Disconnect negative terminal of battery.

Inspection

Inspection of smooth performance of the engine should be performed at a temperature about 0 °C to 60 °C (32 °F to 140 °F).

Engine runs sluggishly

Step	Procedure
1	Remove spark plug connector and remove 1 spark plug from each cylinder.
2	Torque must be determined with a suitable jig. To do this, determine the maximum occurring torque on the propeller shaft necessary to move the whole crank drive. The torque must be max. 150 Nm (111 ft.lb). If the maximum torque is exceeded, perform the following inspections: <ul style="list-style-type: none">• Carry out detailed inspection of the affected gearbox components• Carry out detailed inspection of crank drive

BRP-Rotax
MAINTENANCE MANUAL LINE

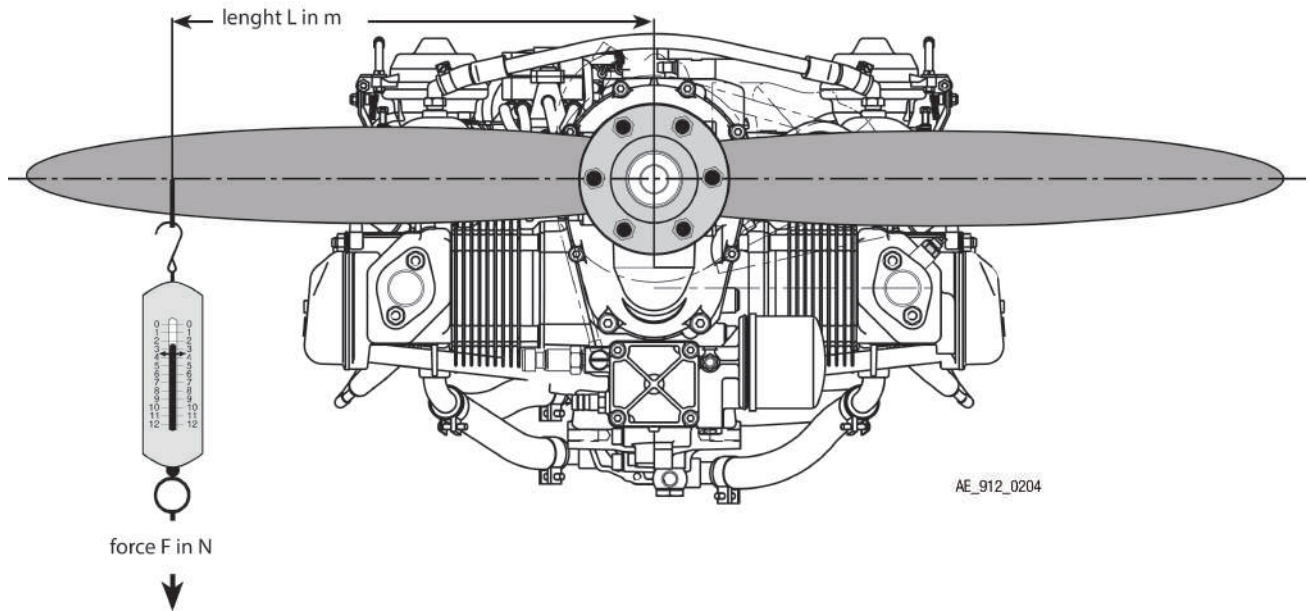

Figure 5.26: Inspection of smooth performance TYPICAL

NOTE

Always use protection of propeller edge when doing this test.

SUDDEN DROP IN BOOST PRESSURE AND SPEED

General note

NOTICE	
If there is damage to the turbocharger, the engine must be sent to the authorized overhaul facility for overhaul.	

Sudden drop in boost pressure and speed	
Step	Procedure
1	Visual inspection of the engine, in particular. <ul style="list-style-type: none"> • Turbocharger • Air intake system
2	Check wiring. See Chapter 12-20-00 section Check of wiring. <p>NOTE</p> <p><i>If no mechanical damage is detected during the visual inspection, check the boost pressure control. See Chapter 76-00-00 of the Maintenance Manual Heavy (MMH).</i></p>

BRP-Rotax
MAINTENANCE MANUAL LINE

Sudden drop in boost pressure and speed	
Step	Procedure
3	Check oil consumption.
4	Oil level check. See Chapter. 12-10-00 section Oil level check/Replenish.

SUDDEN INCREASE IN BOOST PRESSURE AND SPEED

⚠ WARNING
<p>Non-compliance can result in serious injuries or death! The engine must not be taken into operation before having corrected the cause of deficiency.</p>

NOTICE
<p>If the permissible operating limits are exceeded or values fall below the minimum, the corresponding checks must be also be carried out.</p>

Sudden increase in boost pressure and speed	
Step	Procedure
1	Visual inspection of the engine, in particular. <ul style="list-style-type: none"> • Turbocharger • Air intake system
2	Check wiring. See Chapter 12-20-00 section Check of wiring. NOTE <i>If no mechanical damage is detected during the visual inspection, check the boost pressure control (TCU). See Chapter 76-00-00 of the Maintenance Manual Heavy (MMH).</i>

PERIODIC RISE AND FALL IN BOOST PRESSURE AND SPEED (VIBRATION OF TURBO CONTROL UNIT)

⚠ WARNING
<p>Non-compliance can result in serious injuries or death! The engine must not be taken into operation before having corrected the cause of deficiency.</p>

BRP-Rotax
MAINTENANCE MANUAL LINE

NOTICE

If the permissible operating limits are exceeded or values fall below the minimum, the corresponding checks must be also be carried out.

Periodic rise and fall in boost pressure and speed

Step	Procedure
1	Visual inspection of the engine, in particular. <ul style="list-style-type: none">• Turbocharger• Air intake system
2	Check wiring. See Chapter 12-20-00 section Check of wiring. NOTE <i>If no mechanical damage is detected during the visual inspection, check the boost pressure control (TCU). See Chapter 76-00-00 of the Maintenance Manual Heavy (MMH).</i>

RED BOOST LAMP OF THE BOOST PRESSURE CONTROL LIGHTS UP CONTINUOUSLY

General note

⚠ WARNING

Non-compliance can result in serious injuries or death!
The engine must not be taken into operation before having corrected the cause of deficiency.

Red boost lamp lights up

When the red boost lamp lights up, this indicates that the nominal pressure in the airbox has been exceeded.
Depending on how long the limit is exceeded, increased wear as a result of thermal overload can be expected at cylinders, valves and spark plugs.

Checks

NOTICE

If the permissible operating limits are exceeded or values fall below the minimum, the corresponding checks must be also be carried out.

The following checks must be carried out:

BRP-Rotax
MAINTENANCE MANUAL LINE

Red boost lamp lights up continuously Limit exceeded for up to 1 min.	
Step	Procedure
1	Visual inspection of the engine, in particular. <ul style="list-style-type: none"> • Turbocharger • Air intake system
2	Check wiring. See Chapter 12-20-00 section Check of wiring. NOTE <i>If no mechanical damage is detected during the visual inspection, check the boost pressure control (TCU). See Chapter 76-00-00 of the Maintenance Manual Heavy (MMH).</i>

No immediate checks are necessary as long as no further operating limits have been exceeded.

Red boost lamp lights up continuously If the value was exceeded for more than 1 min.	
Step	Procedure
1	Inspection of the <ul style="list-style-type: none"> • Pistons • Cylinders • Valves • Cylinder heads is necessary.

RED BOOST LAMP OF THE BOOST PRESSURE CONTROL IS FLASHING

General note If the red boost lamp flashes, this indicates that the time limit for the 5-minute take-off performance limit has been exceeded.
 Depending on how long the limit has been exceeded, increased wear as a result of thermal overload can be expected at cylinders, valves and spark plugs.

Checks The following checks must be carried out:

BRP-Rotax
MAINTENANCE MANUAL LINE

Red boost lamp lights is flashing	
Step	Procedure
1	Check wiring. See Chapter 12-20-00 section Check of wiring. NOTE <i>If no mechanical damage is detected during the visual inspection, check the boost pressure control (TCU). See Chapter 76-00-00 of the Maintenance Manual Heavy (MMH).</i>
Red boost lamp lights is flashing Limit exceeded for up to 1 min.	
Step	Procedure
1	No immediate checks are necessary as long as no further operating limits have been exceeded.

NOTICE
If the permissible operating limits are exceeded or values fall below the minimum, the corresponding checks must be also be carried out.

Red boost lamp lights is flashing Limit exceeded for 1 to 3 min.	
Step	Procedure
1	Visual inspection of the engine. See Chapter 12-20-00 section Examination after engine failure.
2	Check the spark plugs. See Chapter 12-20-00 section Inspection and replacement of spark plugs.
3	Check compression pressure. See Chapter 12-20-00 section Checking the compression.
Red boost lamp lights is flashing Limit exceeded for over 3 min.	
Step	Procedure
1	Inspection of the <ul style="list-style-type: none"> • Pistons • Cylinders • Valves • Cylinder heads is necessary.

ORANGE CAUTION LAMP OF THE BOOST PRESSURE CONTROL IS FLASHING

⚠ WARNING
<p>Non-compliance can result in serious injuries or death!</p> <p>The engine must not be taken into operation before having corrected the cause of deficiency.</p>

NOTICE
<p>If the permissible operating limits are exceeded or values fall below the minimum, the corresponding checks must be also be carried out.</p>

NOTE

If the lamp is not lit up, the boost pressure control is ready for operation.

Orange lamp flashes

If the orange lamp flashes, this indicates an operating or functional fault of the turbo control unit or related components.

Emergency values

In the event of a fault, e.g. as a result of a circuit break, the TCU switches internally to the pre programmed “emergency values“ or (default values), to ensure continued operation of the engine.

NOTICE
<p>In this emergency program, monitoring of the respective channel, e.g. over-speeding, is no longer possible. Monitoring is inactive.</p>

Checks

The following checks must be carried out:

Orange caution lamp lights is flashing	
Step	Procedure
1	<p>Visual inspection of the engine, in particular.</p> <ul style="list-style-type: none"> • Turbocharger • Air intake system
2	<p>Check wiring. See Chapter 12-20-00 section Check of wiring.</p> <p>NOTE</p> <p><i>If no mechanical damage is detected during the visual inspection, check the boost pressure control. See Chapter 76-00-00 of the Maintenance Manual Heavy (MMH).</i></p>

BRP-Rotax
MAINTENANCE MANUAL LINE

FAILURE OF THE VOLTAGE SUPPLY FOR THE TURBO CONTROL UNIT (TCU)

General note

⚠ WARNING
Non-compliance can result in serious injuries or death! The engine must not be taken into operation before having corrected the cause of deficiency.

NOTICE
If the permissible operating limits are exceeded or values fall below the minimum, the corresponding checks must be also be carried out.

Checks

The following checks must be carried out:

Failure of the voltage supply for the Turbo Control Unit (TCU)	
Step	Procedure
1	Visual inspection of the engine, in particular. <ul style="list-style-type: none">• Electric system (voltage supply)
2	Check wiring. See Chapter 12-20-00 section Check of wiring. NOTE <i>If no mechanical damage is detected during the visual inspection, check the boost pressure control. See Chapter 76-00-00 of the Maintenance Manual Heavy (MMH).</i>

LIGHTNING STRIKE

General note

An indirect lightning strike is a strike on the aircraft fuselage, the wings or propeller. A direct lightning strike is a strike which acts directly on the engine.

Different types of damage can be caused depending on the type of lightning strike.

Indirect lightning strike

Perform the corresponding inspections/repairs depending on the functional defects found.

Indirect lightning strike	
Step	Procedure
1	Inspect the condition of the engine.
2	Inspect the mechanical actuation systems in the engine.
3	Inspect the electrical wiring and components.

BRP-Rotax MAINTENANCE MANUAL LINE

Indirect lightning strike	
Step	Procedure
4	Crank the engine and check that it rotates freely.
5	Perform an engine test run.

Heat damage due to indirect lightning strike:

Detailed findings will need to be obtained for affected components. Always replace components if visible signs of damage are evident or if you are in any doubt.

Electrical and magnetic damage due to indirect lightning strike:

Detailed findings will need to be obtained for affected components. Always replace components if visible signs of damage are evident or if you are in any doubt.

Direct lightning strike

NOTICE

After direct lightning strike, the engine has to be overhauled in according to the current Overhaul Manual (OHM) for the respective engine type.

Overhaul Manual (OHM) and its appendix is available for any appropriately rated person or entity on request and by following the standards of the original manufacturer.

REPORTING

General note

In case of any relevant occurrences that may involve malfunction of the engine, the form on the next page should be filled out and sent to the responsible ROTAX® Authorized Aircraft engines distributor or their independent Service Center. This is valid for all ROTAX® Aircraft engines types (certified – according to the regulation of EASA part 21A.3 / FAR 21.3) (non-certified – ASTM compliant, etc...).

NOTE

The form is also available from the official ROTAX® AIRCRAFT ENGINES Website in electronic version.

www.flyrotax.com

BRP-Rotax
MAINTENANCE MANUAL LINE



CUSTOMER SERVICE INFORMATION REPORT

WHEN / WHERE / WHAT

Accident / Incident Date _____ State / Country _____

Location of Occurrence _____

Headline _____

Narrative

AIRCRAFT IDENTIFICATION

Aircraft registration _____ Aircraft category _____

Manufacturer _____ Model / Series _____

Serial Number _____ Aircraft total time _____

FLIGHT DETAILS

Flight phase _____ Operator _____

Last departure point _____ Planned destination _____

ENGINE INFORMATION

Type _____ Serial Number _____

Time since new [h] _____ Time since overhaul [h] _____

Date overhaul _____ Date inspection / maintenance _____

PROPELLER INFORMATION

Manufacturer _____ Model / Series _____

Serial Number _____ Propeller position _____

FLYROTAX.COM

* and TM are Trademarks of BRP-Rotax GmbH & Co KG.
© 2020 BRP-Rotax GmbH & Co KG. All rights reserved.

EASA21J.048



Figure 5.27: Form

BRP-Rotax
MAINTENANCE MANUAL LINE

INTENTIONALLY LEFT
BLANK

BRP-Rotax
MAINTENANCE MANUAL LINE

Chapter: 12-00-00
MAINTENANCE OF THE SYSTEMS

TOPICS IN THIS CHAPTER

Introduction

The section "Maintenance of the systems" is associated with other sections. It serves only as a supplement to and further explanation of the maintenance check list (See Chapter 05-20-00).

NOTE

For reasons of clarity, only headlines and keywords are listed in the Maintenance Schedule. Please refer to the following pages for further explanation if needed. As far as possible, the content has been arranged according to system.

BRP-Rotax
MAINTENANCE MANUAL LINE

INTENTIONALLY LEFT
BLANK

BRP-Rotax
MAINTENANCE MANUAL LINE

Chapter: 12-10-00
REPLENISHING OPERATING FLUIDS

TOPICS IN THIS CHAPTER

Servicing points on the engine	2
Fluid capacities	3
Cooling system	4
Coolant check/replenish	4
Lubrication system	6
Oil level check/Replenish	6

Introduction The engine should always be in a horizontal position before checking the fill levels.

ENVIRONMENTAL NOTE

**All operating materials and cleaning products endanger the environment by
improper disposal.
Dispose of the operating materials in an environmentally sound way!**

SERVICING POINTS ON THE ENGINE

Overview

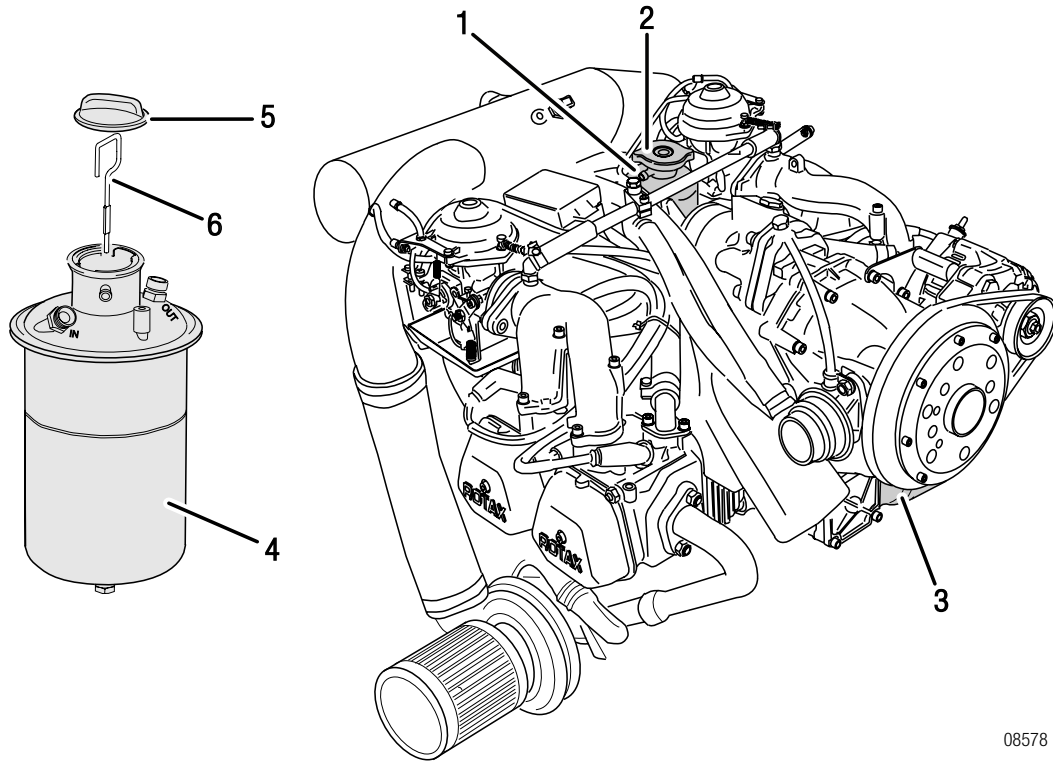

08578

Figure 6.1

- | | | | |
|---|---------------------------------|---|--------------|
| 1 | Expansion tank | 2 | Radiator cap |
| 3 | Oil filter | 4 | Oil tank |
| 5 | Oil tank cover, without venting | 6 | Oil dipstick |

BRP-Rotax
MAINTENANCE MANUAL LINE

FLUID CAPACITIES

General note

NOTICE
The operation of the engine may be adversely affected if non-approved or contaminated fuel, oil or coolant are used. Any mixing of different manufacturers and types should be avoided. The use of additives may result in damage.

System

Overview



See Operators Manual (OM) for the respective engine type.

System	Fill capacity	Details about the operating fluids
Fuel system	Refer to the relevant specifications provided by the aircraft manufacturer.	Refer to the corresponding chapter in the Flight Manual.
Cooling system	Approx. 1.5 l (0.4 US gal.).	Refer to the corresponding chapter in the Operators Manual (OM).
Oil system	MIN mark corresponds to 2.5 l (0.66 US gal.) and MAX mark corresponds to 3.0 l (0.8 US gal.).	Refer to the corresponding chapter in the Operators Manual (OM).

NOTE

BRP-Rotax can give an approx value on the fill capacity depending on aircraft design and positions of radiators and tanks. The volume may differ from this value. Always check the relevant specifications provided by the aircraft manufacturer.

BRP-Rotax
MAINTENANCE MANUAL LINE

COOLING SYSTEM

General note

⚠ WARNING

Risk of burns and scalds. Hot engine parts.
Always allow engine to cool down to ambient temperature before starting work.

⚠ WARNING

Risk of Burns!
Never open the radiator cap when the cooling system is hot. For safety's sake, cover cap with a rag and open slowly. Sudden opening of the cap could provoke the escape of boiling coolant and result in scalding.

ENVIRONMENTAL NOTE

Coolant and mixtures of coolant and water have to be treated as hazardous waste!

COOLANT CHECK/REPLENISH

Special tool

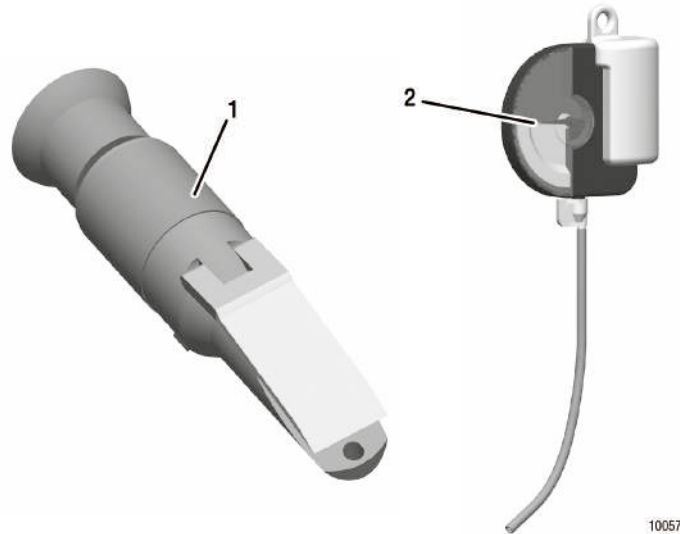

Figure 6.2: Special tool

Part number	Description
part no. n.a	Densimeter (1)
part no. n.a	Glycol tester (Refractometer)(2)

Instruction

To refill the coolant the following steps are necessary.

BRP-Rotax MAINTENANCE MANUAL LINE

Step	Procedure
1	Open the radiator cap (1) on the expansion tank (2).
2	Check the coolant level. The coolant level must be filled up to the top (see Figure).
3	Inspect coolant with densimeter or glycol tester. Strongly discolored or thickened coolant must be replaced.

NOTICE

Use only coolant as recommended in the current Operators Manual (OM)

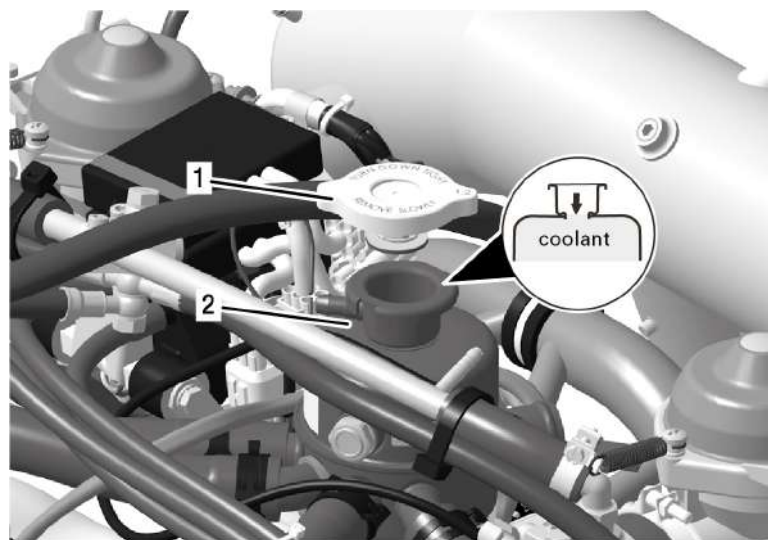

AE 2_0324

Figure 6.3: TYPICAL

1 Radiator cap

2 Expansion tank

Engine test run

Engine test run is necessary:

Step	Procedure
1	Operate the engine until the temperatures have stabilized for a period of 5 min. (engine oil temperature between 50 to 70 °C (122 - 160 °F)).
2	Switch the engine OFF.
3	Allow the engine to cool down.
4	Check for leaks.
5	Check the coolant level and top up with coolant as required.

BRP-Rotax
MAINTENANCE MANUAL LINE

LUBRICATION SYSTEM

General note

⚠ WARNING
Risk of burns and scalds. Hot engine parts. Always allow engine to cool down to ambient temperature before starting work.

⚠ WARNING
Risk of electric shock! Ignition "OFF" and system grounded! Disconnect negative terminal of battery.

ENVIRONMENTAL NOTE
Protect the environment. Do not harm the environment by spilling oil. Dispose of oil in an environmentally friendly manner.

OIL LEVEL CHECK/REPLENISH

Preparatory tasks Before checking the oil level, make sure that there is no excessive residual oil in the crankcase.

Instruction For checking and before replenish proceed as follows.

Step	Procedure
1	Remove cap from oil tank.
2	Turn the propeller several times by hand in direction of engine rotation to pump residual oil from the engine to the oil tank.
3	This process is completed when air flows back to the oil tank. This air flow can be perceived as a murmur (gurgling) when the oil tank cover without venting is removed.
4	Pull out the oil dipstick (2).
5	The oil level in the oil tank should be between the two marks (max./min.) on the oil dipstick, but must never fall below the min. mark.
6	During standard engine operation, the oil level should be mid-way between the max. and min. marks, as at higher oil level (over servicing), oil will escape via the venting passage. Difference between "max." and "min". - mark = 0.45 l (0.95 liq.pt).

BRP-Rotax
MAINTENANCE MANUAL LINE

NOTICE

For longer flights replenish oil to max. mark to warrant more oil reserve.

NOTICE

Only use brand name oil in accordance with the latest Operators Manual (OM) and the latest Service Instruction "Selection of suitable operating fluids" of the respective engine type.

Step	Procedure
7	Replenish oil as required.
8	Check oil level - Marks on the oil dipstick.
9	Fit the oil dipstick and tighten the oil tank cover (1) by hand.

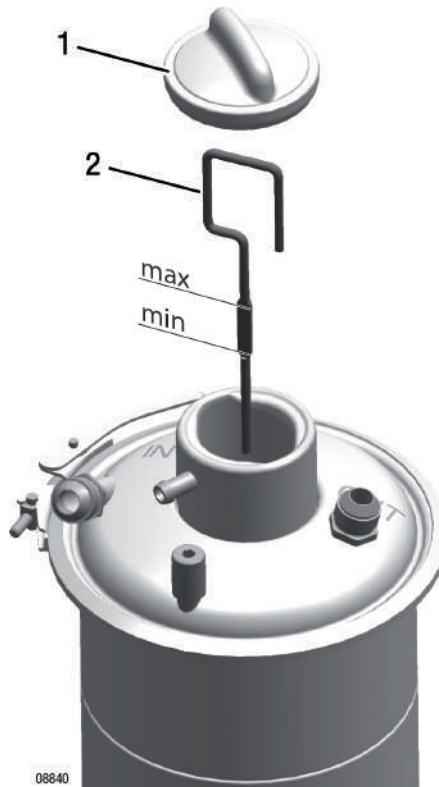

Figure 6.4: Oil level check/Replenish

1 Oil tank cover, without venting

2 Oil dipstick

BRP-Rotax
MAINTENANCE MANUAL LINE

Engine test run An engine test run is necessary:

Step	Procedure
1	Check the oil level and top up with oil as required.
2	Operate the engine until the temperatures have stabilized for a period of 5 min. (engine oil temperature between 50 to 70 °C (122 - 160 °F).
3	Switch the engine OFF.
4	Allow the engine to cool down.
5	Check for leaks.

BRP-Rotax
MAINTENANCE MANUAL LINE

Chapter: 12-20-00
SCHEDULED MAINTENANCE

TOPICS IN THIS CHAPTER

Engine cleaning	3
Visual inspection	4
Checking the engine suspension	5
Corrosion.....	5
Leakage check	6
Differential pressure check	8
Compression check for fault-tracing	11
Locking/Loosening of the crankshaft	13
Test run of engine	15
Checking the V-belt tension	17
Belt tension adjustment.....	17
Air intake system	19
Checking air intake system.....	19
Cleaning the dry air filter	19
Replacing the dry air filter.....	21
Cooling system	22
Checking the cooling system	23
Replacing the coolant	23
Flushing the cooling system	25
Expansion tank, radiator cap	26
Overflow bottle	27
Accessories (including radiator, radiator hoses, hose clamps, cooling air ducts)	27
Fuel system	28
Carburetor synchronization	29
Mechanical synchronization	30
Pneumatic synchronization	31
Idle speed check	35
Operating range check.....	36
Checking of the float chamber	38
Check the weight of floats	39
Idle speed adjustment.....	41
Checking the carburetor actuation	42
Leak tests	43
Checking the fuel lines.....	43
Fuel pumps.....	44
Inspection of the fuel filter in the airframe.....	44
Check valves	44
Fuel rail	44
Lubrication	45
Oil change	47

BRP-Rotax
MAINTENANCE MANUAL LINE

Oil filter removing	48
Inspecting of the oil filter components.....	49
Installing new oil filter.....	51
Cleaning the oil tank	53
Purging the oil system.....	55
Flushing the oil circuit	55
Inspecting the magnetic plug	57
Installation of the magnetic plug.....	58
Electric system.....	59
Check of wiring.....	60
Replacement of spark plugs	61
Remove the spark plugs	61
Inspection of spark plugs.....	61
Installation of spark plug	63
Turbocharger.....	65
Propeller gearbox.....	67
Checking the propeller gearbox	67
Checking the friction torque in free rotation.....	67

Introduction This chapter relates in particular to the maintenance work mentioned in the Maintenance Schedule for the various engine systems and covers the work in more detail.

BRP-Rotax
MAINTENANCE MANUAL LINE

ENGINE CLEANING

General note

ENVIRONMENTAL NOTE

When cleaning the engine, the dissolved residues of fuel, oil and other environment-contaminating agents are rinsed off.
Collect the residual liquids and dispose of them in an environmentally sound way.

NOTICE

Do not use flammable liquids or caustic cleaning agents for cleaning the engine.

Cleaning agents

Use of a commercially available cold cleaning agent for the engine is recommended. See [Chapter 05-00-00 section Consumable Materials](#).

Cleaning

NOTICE

Never clean an engine with a high pressure cleaner. This is detrimental to the electrical installations and shaft seals. Oxidation of the various components and their potential failure may occur.

NOTICE

Before cleaning, all openings through which cleaning agents and/or dirty water could enter the engine must be closed off.
Failure to do this may result in engine damage!

NOTE

Always clean engine in cold state.

The engine must always be cleaned with due care and attention to detail. Plug openings as required before cleaning.

After each cleaning

After each cleaning procedure, dry all electrical components such as

- Ignition unit
- Spark plug connector
- Clamp connections etc.
- ECU and Fuse box + connections

by use of compressed air to prevent increased electrical resistance caused by corrosion.

BRP-Rotax
MAINTENANCE MANUAL LINE

VISUAL INSPECTION

General note General visual inspection of the engine for damage or abnormalities. For definition and scope of visual inspection. See [Chapter 05-20-00 section Visual inspection](#).

Abnormalities Take note of changes caused by temperature influence.
During a visual inspection you should focus on the following points in particular:

- Exhaust system
- Engine suspension frame
- Heat shrink sleeve
- Sensor technology
- Oil filter
- Venting hoses (oil tank)
- Airbox
- Fuel line (steel)
- Wiring harness
- Coolant hoses

NOTE

On turbocharger

- Turbocharger with attachment

Step	Procedure
1	Only a visual inspection is necessary.
2	Check compressor impeller for mechanical damage and free movement.
3	Carry out visual inspection of compressor and turbo housing for cracks.

Condensation trap

NOTE

*Only fitted on engines with airbox of older model.
There is a condensation trap between the airbox and the pressure sensor. It must be replaced when it fills with condensation.*

Pressure connecting lines

See Chapter 73-00-00 of the Maintenance Manual Heavy (MMH).

⚠ WARNING

Non-compliance can result in serious injuries or death!

Since a failure of pressure interconnections of airbox, float chambers, fuel control and pressure sensor would possibly result in an engine stop all these interconnections have to be made very carefully.

- Airbox – fuel pressure regulator
- Airbox – air pressure sensor
- Airbox – 3 way solenoid enrichment valve connecting hoses

BRP-Rotax MAINTENANCE MANUAL LINE

- Enrichment valve – 2x Float chamber ventilation

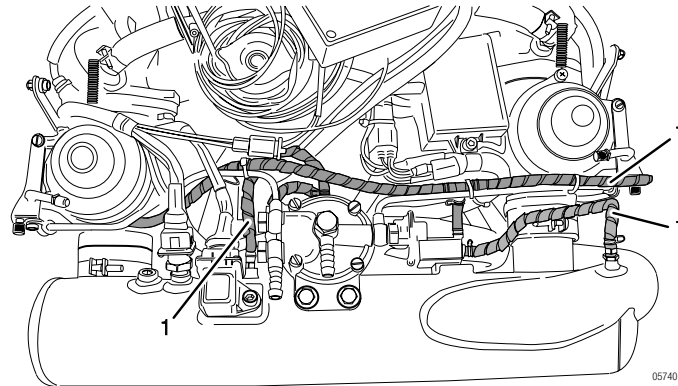

Figure 7.1

1 Connecting lines

CHECKING THE ENGINE SUSPENSION

General note

NOTICE
Be sure to use the recommended tightening torque for the specified fastener.

Checking the engine suspension

Step	Procedure
1	Verify the engine suspension points on the crankcase for tight fit and damage including cracks.
2	Inspect the surroundings of engine attachment on crankcase and gearbox. If there is discoloration of the crankcase around the attachment points (black ring), there may be loose attachments.
3	Inspect engine isolating mounts including for heat damage, wear and cracks.
4	Inspect engine suspension frame.

CORROSION

Definition

Corrosion is a natural process which attacks and potentially damages metals via an electrochemical reaction. For more detailed information about different types of corrosion and corresponding methods for dealing with corrosion refer to the FAA Advisory Circular AC 43.13. See chapter “AC 43.13-1B Maintenance and Repair”.

BRP-Rotax
MAINTENANCE MANUAL LINE

LEAKAGE CHECK

General note

NOTICE
Leaking connections can lead to engine problems or engine failure!

Visual inspection of the whole engine for leaks. If leaks are visible, locate the cause and remedy the fault.

Water pump

Checking water pump for leaks.

If the leakage bore, located at the base of the ignition housing, is dripping oil (see step 4), the oil seal on the water pump shaft may be defective and must be replaced. In the case of coolant drips at the leakage bore (see step 4), the coolant mechanical seal must be replaced.

NOTE

The internal rotary seal has ceramic sealing surface which is lubricated by the cooling liquid. Therefore signs of dried coolant liquid (like discolouration,...) at the leakage bore is normal. If an excessive coolant leak is suspected, the following steps must be taken:

Step	Procedure
1	Clean the engine.
2	Operate the engine until the temperatures have stabilized for a period of 5 min. (engine oil temperature between 50 ° to 70 °C (122 ° - 158 °F).
3	Switch "OFF" ignition and secure engine against unintentional operation. Secure aircraft against unauthorized operation.
4	For a period of 1 minute after the engine has been stopped, no liquid must drip down.

Coolant hoses

Check coolant hoses and connections and fittings for leakage. Examine the surrounding area to see if there are any leaks!

Hose clamps, kinks

Check all hoses, particularly in the area of the hose clamps and hose connections, for porosity, damage and kinks. If damage is detected, replace hose immediately.

Fuel line + hoses

Inspect fuel lines (both steel and flex hoses), their connections and screw fasteners. Look for scuffing marks or other damage.

NOTICE
Avoid overtightening the connections and fasteners. Always comply with the specified torque!

Complete a detailed visual inspection. When checking steel fuel lines (1), pay attention to the connection areas (2). Look for leaks and cracks.

BRP-Rotax
MAINTENANCE MANUAL LINE

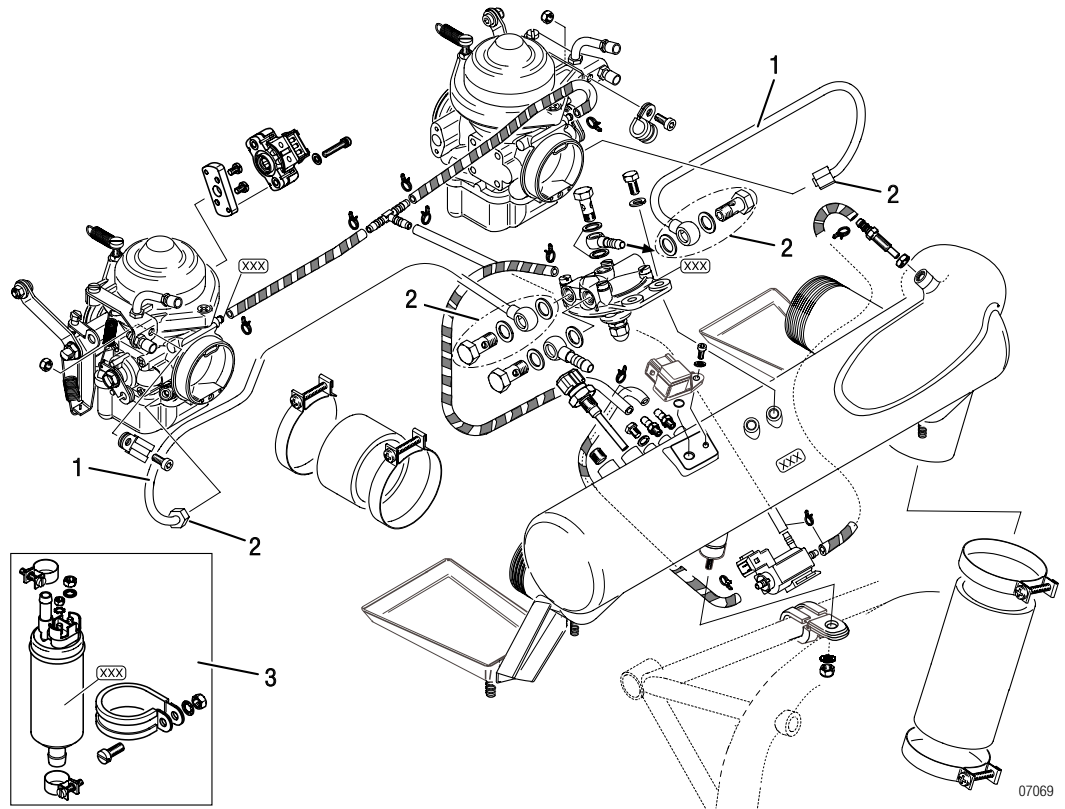

Figure 7.2: Connections and fuel lines

- 1 Fuel lines (steel)
- 2 Connections (fittings)
- 3 Fuel pump

2 Connections (fittings)

Fuel pump

Inspect fuel pump and isolating flange for leaks. For a period of 1 minute after shut down the engine must not drip oil out of the venting tube, In case of uncertainty determine the oil amount. An oil leak is when after 20 min engine run more than 0.5 ml of oil loss is detected.

Oil hoses

Inspect all oil feed hoses from the oil tank to the oil cooler and to the engine. Also inspect the oil return hose from the crankcase to the oil tank. Check the pressure oil hose from the oil pump to the governor flange of the governor.

BRP-Rotax
MAINTENANCE MANUAL LINE

DIFFERENTIAL PRESSURE CHECK

General note

⚠ WARNING

Risk of electric shock!
Ignition "OFF" and system grounded!

⚠ WARNING

Danger of life threatening injuries caused by the propeller, rotating and stressed parts of the engine!

Engine (and propeller) may suddenly rotate if the piston is not at top dead center. Always secure propeller and keep blade path clear before adding pressurized air to the cylinder.

BRP-Rotax
MAINTENANCE MANUAL LINE

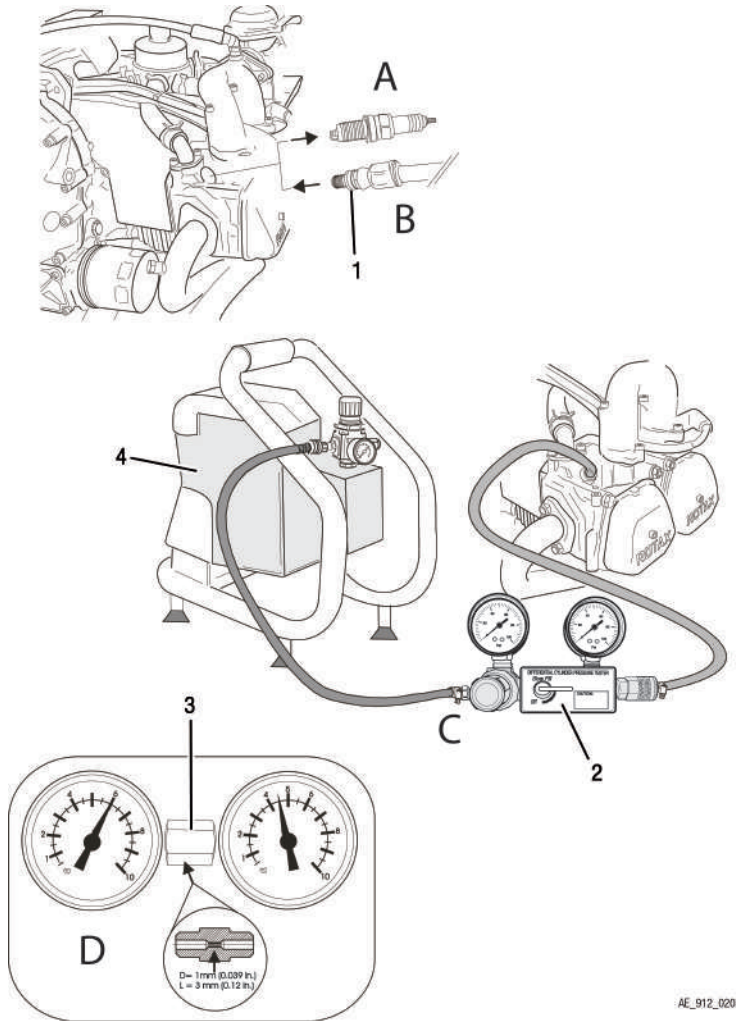

Figure 7.3: Differential pressure check. TYPICAL

- | | |
|---|--|
| <p>1 <i>Adaptor</i></p> <p>3 <i>Orifice jet</i></p> | <p>2 <i>Manometer/Test gauges set</i></p> <p>4 <i>Compressor</i></p> |
|---|--|

Special tools

To measure the differential pressure the following special tools and equipment are necessary.

Part no.	Description
n.a.	Compressed air approx. 6 bar (80 psi).
n.a	2 pressure gauges.
n.a	Orifice jet*, of 1 mm (0.04 in) inner diameter and 3 mm (0.12 in) length. * or equivalent e.g. orifice diameter 0.040 in., long 0.0250 in., 60° degree approach angle according to AC43.13, latest issue.

BRP-Rotax
MAINTENANCE MANUAL LINE

Part no.	Description
n.a	Adapter to spark plug thread.
n.a	Connect line.

Instruction

Testing is carried out using the **differential pressure test procedure**.

Step	Procedure
1	Operate the engine until the temperatures have stabilized for a period of 5 min. (engine oil temperature between 50 to 70 °C (122 - 160 °F).
2	Remove the upper spark plugs. Prevent dirt or other foreign particles from entering the engine (A).
3	Starting with cylinder head 1 move piston to TDC position.
4	Screw adaptor (1) into the spark plug thread and connect up the two pressure gauges (2) with the orifice jet (3) between them (B).
5	Now put constant pressure, between 5.5-6 bar (80–87 psi) on the line and take readings at pressure gauge (C)..
6	Repeat this procedure on all 4 cylinder heads.

Value

The maximum permissible pressure drop is 25 %, e.g. from 6 to 4.5 bar (87 psi to 65 psi) (D).

Procedure if maximum permissible pressure drop is out of range:

Recheck the readings after operating the engine in a test run for at least 3 minutes. This will allow the piston rings to be wetted with oil. Measure the pressure drop again as described in the differential pressure test procedure. If the pressure loss is still out of range, valve seat debris removal procedure must be carried out.

Valve seat debris removal procedure

Step	Procedure
1	Remove the valve cover according to the latest Maintenance Manual Heavy (MMH).
2	Turn the crankshaft into the position, so that the intake valve is closed.
3	Place a plastic drift (2) on the rocker arm (1) (directly over the inlet valve stem). See Fig. Valve seat debris removal .
4	Use a hammer to give a slight blow onto the fibre drift to dislodge any foreign material between the intake valve face and seat. During this step the cylinder must be pressurized by using the setup used for the differential pressure test procedure to allow carrying away debris from the valve seat.
5	Turn the crankshaft into a position, so that the exhaust valve is closed and perform step 3 and 4 for the exhaust valve.

BRP-Rotax MAINTENANCE MANUAL LINE

Step	Procedure
6	Install valve cover according to the latest Maintenance Manual Heavy (MMH).
7	Measure the pressure drop again as described in the differential pressure test procedure.

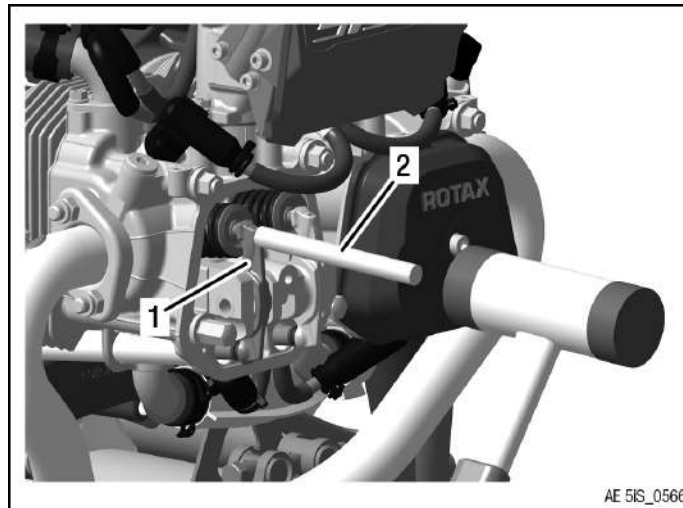

Figure 7.4: Valve seat debris removal

1 *Rocker arm*

2 *Plastic drift*

If the pressure drop value is still out of range, heavy maintenance must be carried out by authorized persons (iRMT, Level Heavy Maintenance).

Following troubleshooting reasons might be applicable but are not exclusively limited to:

- Excessive cylinder wall and/or piston ring wear
- Broken piston rings
- Burned valves
- Piston damage

COMPRESSION CHECK FOR FAULT-TRACING

General note

Official and accepted measurement method is the differential pressure check, it is possible to check the engine with a compression check method when differential pressure check reading is unclear. Mainly - always perform the differential pressure check. In the course of fault-tracing a compression check can also be performed.

A compression tester is required to check compression. The compression should be between 9 and 12 bar (130 psi and 174 psi).

Instruction

Compression check for fault-tracing.

BRP-Rotax MAINTENANCE MANUAL LINE

Step	Procedure
1	Operate the engine until the temperatures have stabilized for a period of 5 min (engine oil temperature between 50 to 70 °C (122 - 160 °F).
2	Unscrew and remove top spark plugs.
3	Press compression tester (1) over the spark plug hole and use the starter to turn the engine over with open throttle until maximum pressure is reached.
4	Successively take readings on all four cylinders and compare results.

Measurement

Individual readings for the cylinder must not differ by more than 2 bar (29 psi).

If the value is below 6 bar (87 psi), inspection, repair or overhaul must be carried out in accordance with the BRP-Rotax instructions for continued airworthiness

- Detailed inspection of affected engine components.

Special tools

For accomplishment the following special tool is required:

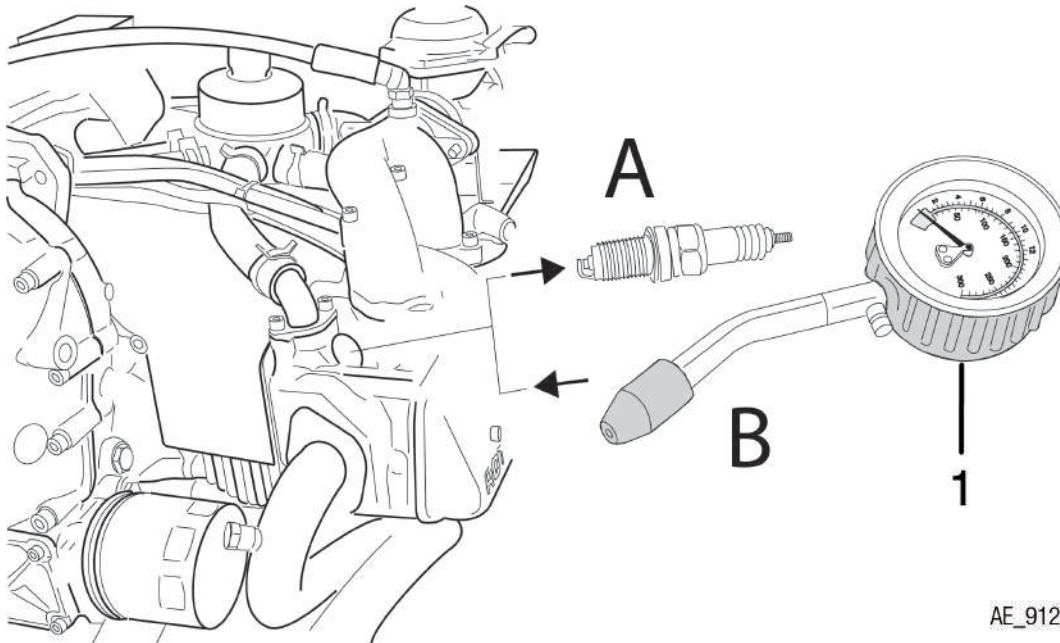

AE_912_0203

Figure 7.5: Compression check for fault-tracing. TYPICAL

Part no.	Description
n.a.	Compression tester (1)

LOCKING/LOOSENING OF THE CRANKSHAFT

Locking of the crankshaft

⚠ WARNING

Risk of burns and scalds. Hot engine parts.
Always allow engine to cool down to ambient temperature before starting work.

Special tool

Do not use a substitute part (such a bolt) it may bend and damage crankcase.
For accomplishment the following special tool is required:



Figure 7.6: Special tool

Part number	Description
240880	Thread bolt (1)

Instruction

The following work procedures are to be accomplished:

Step	Procedure
1	Remove the Allen screw (1) M8x20 and sealing ring from the crankcase half (cyl. 2/4).
2	Turn crankshaft/propeller shaft until the piston of cyl. no. 1 and no. 2 are in TDC position and lock crankshaft in this position with the thread bolt (2) part no. 240880. NOTE <i>Turn crankshaft for relief the position indication until the trigger boss (3) is between the both trigger coil (4, 5) at the position. The required recess position of the crankshaft can be additionally verified by looking through the crankcase recess (6) with a flash light.</i>
3	Screw the thread bolt (2) into the crankcase. While doing so, move the crankshaft with the propeller until the locking screw engages in the recess of the crankshaft, and tighten to 10 Nm (89 in.lb).

BRP-Rotax
MAINTENANCE MANUAL LINE

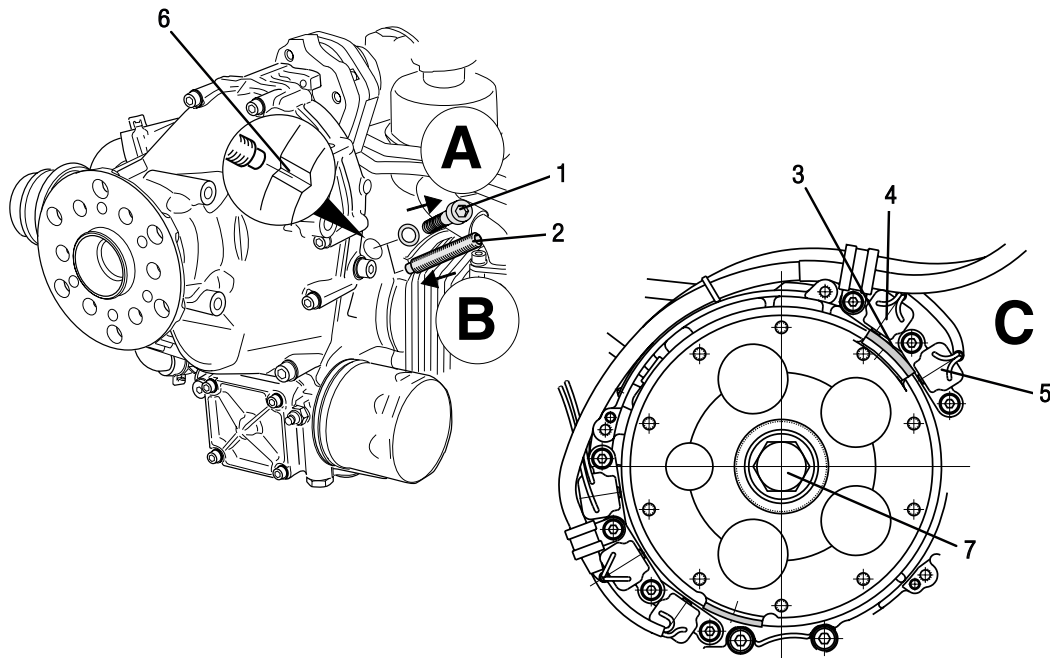

Figure 7.7: Locking/Loosen of the crankshaft.

- | | |
|--|---|
| <p>1 Allen screw M8x20</p> <p>3 Trigger boss</p> <p>6 Crankshaft</p> | <p>2 Thread bolt</p> <p>4,5 Trigger coils</p> <p>7 Hex.screw M16x1.5x40</p> |
|--|---|

Loosen of the crankshaft

After completion of work/check:

Step	Procedure
1	Remove the thread bolt (2) and refit crankshaft Allen screw M8x20 (1) along with a new sealing ring with a dry torque of 15 Nm (133 in.lb).

BRP-Rotax
MAINTENANCE MANUAL LINE

TEST RUN OF ENGINE

General note

⚠ WARNING
Danger of life threatening injuries caused by the propeller, rotating and stressed parts of the engine!
Always observe the engine from a safe place while it is running. Check that the cockpit is occupied by a competent operator.

Preparation

Preparation of the engine for test run:

- Ensure that all the operating fluids (engine oil, coolant, fuel) are replenished to the specified level.
- Make sure that no loose objects (e.g. tools) are left in the engine compartment.
- Inspect tight fit of the propeller.
- Anchor the aircraft suitably to the ground and fix wheel chocks. Ensure that the propeller zone is clear and safe before starting the engine.

Test run

Test run as follows

Step	Procedure
1	Establish fuel supply (open fuel cock).
2	Activate choke.
3	Throttle lever to idle position.
4	Master switch "ON".
5	Ignition for both ignition circuits "ON".
6	Activate starter switch for max. 10 sec. (followed by a cooling period of 2 min.).
7	After engine start, observe oil pressure. Oil pressure has to built up within 10 sec..
8	Let engine run approx. 2 min. at 2000 rpm. Then first use the throttle lever to bring the engine to approx. 2500 rpm and then run through warming up period, until the oil temperature reaches 50 °C (122 °F).
9	Check temperatures and oil pressure: At a steady oil temperature above 50 °C (122 °F) and oil pressure above 2 bar (29 psi) engine speed may be increased.
10	Ignition check as per the current Operators Manual (OM).
11	Conduct a short full throttle run and check that the engine reaches the max. full power speed. Consult the pilot's operating handbook for maximum speed, as it depends on the propeller used.

BRP-Rotax
MAINTENANCE MANUAL LINE

Step	Procedure
12	After full-load run, conduct a short cooling run to prevent formation of vapour lock in cylinder heads. This is necessary to prevent steam locks in the cooling and fuel system after shut-down.
13	Shut engine down. NOTE <i>On switching off the engine switch off ignition and make sure engine can not be started (example: remove start key).</i>
14	Inspect rotary seal for leakage. NOTE <i>Due to the design of the rotary seal, the manufacturer tolerates a certain amount of leakage. If the leakage is in excess of the limit rotary seal must be renewed.</i> Tolerated leakage: For this check the engine must be operated until all temperatures have stabilized for a period of 5 minutes. At that point shut down engine and ensure the ignition is switched off and engine secured against unintentional operation. Coolant must not drip through leakage bore, located at the base of the ignition housing, for a period of 1 minute after the engine has been stopped. In case this leakage test can not be passed, the rotary seal must be replaced.

Engine oil and coolant

⚠ WARNING
Risk of Burns!
Never open the radiator cap when the cooling system is hot. For safety's sake, cover cap with a rag and open slowly. Sudden opening of the cap could provoke the escape of boiling coolant and result in scalding.

Replenish engine oil and coolant as required once engine has cooled down.

Oil filter

NOTICE
If the oil filter has been replaced, re-tighten by hand after the test run on a cold engine.

Check of leaks

Inspect the engine for oil, fuel or coolant leaks and repair as necessary.

CHECKING THE V-BELT TENSION

General note

In the case of configurations with additional auxiliary generator, inspect attachment and V-belt tension.

Checking the V-belt tension

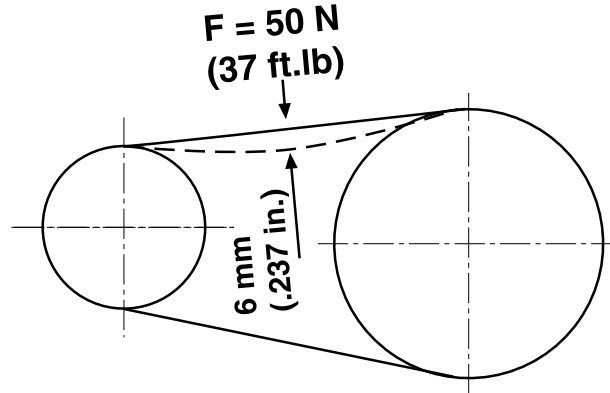

Figure 7.8: Checking the V-belt tension

BELT TENSION ADJUSTMENT

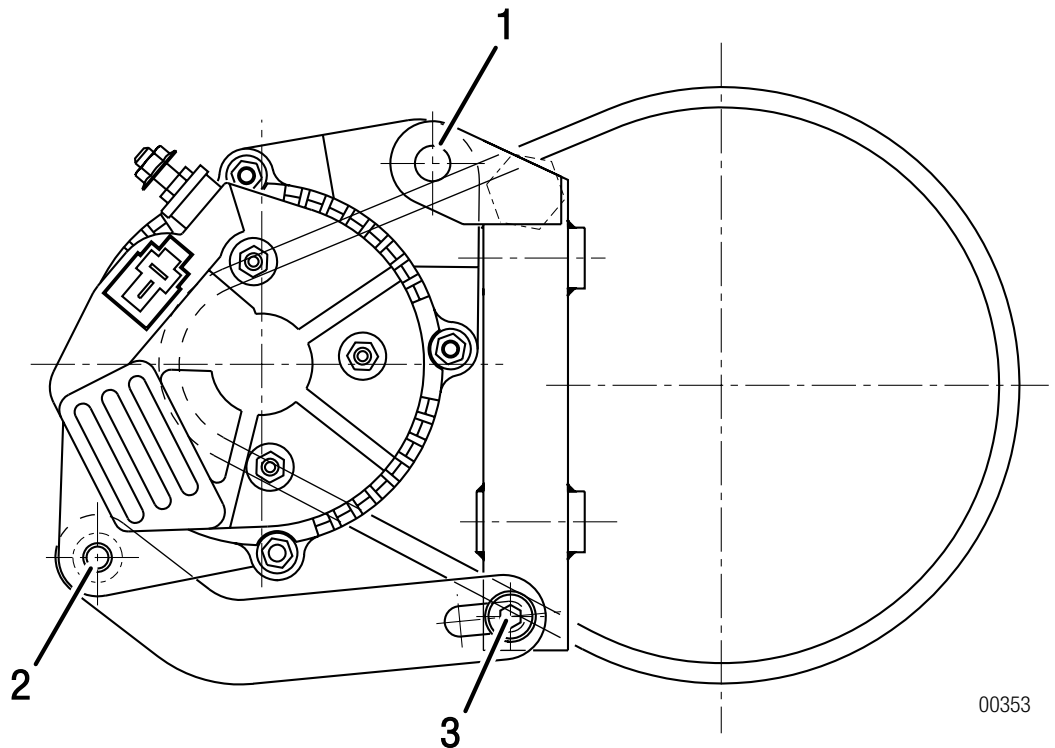

Figure 7.9: Overview

1 Hex. screw M10

2, 3 Allen screw M8

BRP-Rotax
MAINTENANCE MANUAL LINE

Belt tension

To adjust the belt tension:

Step	Procedure
1	Loosen the hex. screw (1) M10 and the two M8 Allen screw (2) and (3).
2	Press the alternator upwards and tighten Allen screw (3).
3	Then tighten hex. screw (1) M10 with tightening torque 40 Nm (30 ft.lb) and Allen screw M8 (2) with tightening torque 22 Nm (16 ft.lb).

AIR INTAKE SYSTEM

CHECKING AIR INTAKE SYSTEM

General note

NOTICE

Blocked air filter.

In the event of dust formation, clean air filter at correspondingly shorter intervals. If filter mat is damaged, replace air filter.

NOTICE

A dirty filter insert will not only reduce the engine performance but might also promote premature wear of the engine.

Carry out visual inspection of dry air filter after prescribed maintenance interval. Clean dirty air filter as described in aircraft manufacturers Maintenance Manual.

Instruction

To check the air intake system the following steps are necessary:

Step	Procedure
1	Visual inspection of the air filter.
2	Visual inspection of the airbox for mechanical damage, cracks, leaks, contamination and secure attachment.
3	Inspect the intake hoses and molded hoses for damage, cracks, breaks, chafing and wear.
4	Check the gaskets. Look for signs of leaks.

CLEANING THE DRY AIR FILTER

General note

NOTICE

Never use gasoline, steam, caustic liquids, strong detergents, particle cleaning agents or high pressure cleaners during this step.

NOTICE

Do not dry over open flame, with compressed air or with hot air gun.

Cleaning

To clean the dry filter the following steps are necessary:

BRP-Rotax
MAINTENANCE MANUAL LINE

Step	Procedure
1	Lightly tap and brush off surface dirt (A).
2	Spray K&N filter cleaner onto filter surface and leave to soak for approx. 10 min. (B).
3	Rinse air filter with low pressure water from inside to outside and let element dry naturally (C).

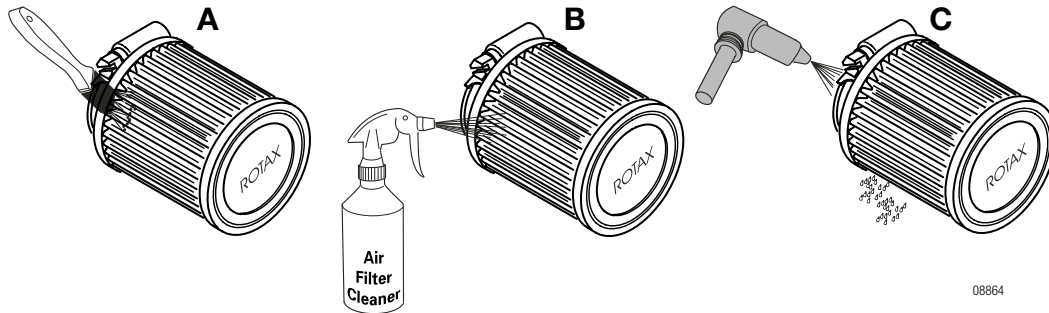

Figure 7.10: Cleaning the dry air filter

After cleaning

NOTICE

Never use gear oil, diesel or engine oil, as they attract humidity. Overoiling of the air filter reduces airflow causing rich mixture.

NOTE

Each filter pleat must have oil applied, by spray or liquid application.

After 5 to 10 min. the filter will be soaked with oil, noticeable by the uniform red coloring.

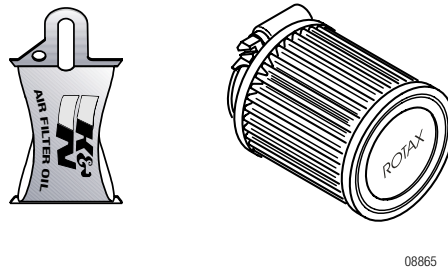

Figure 7.11: After cleaning

BRP-Rotax
MAINTENANCE MANUAL LINE

REPLACING THE DRY AIR FILTER

General note Only use dry type air filters which are specified by the aircraft manufacturer and from ROTAX®.

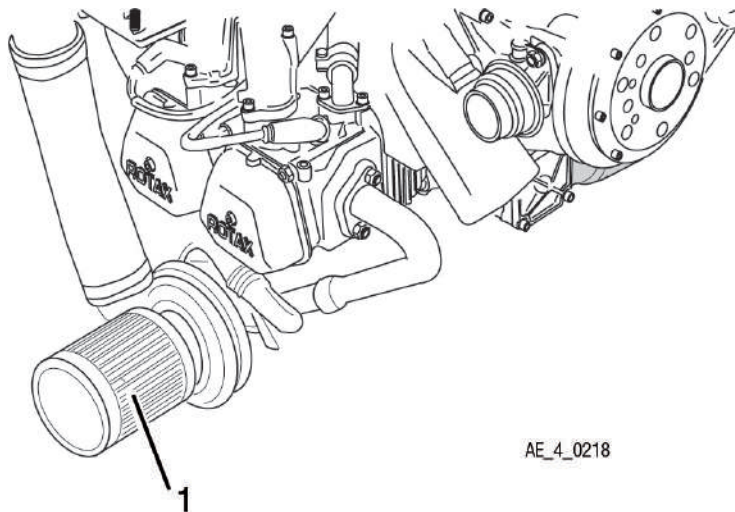

Figure 7.12

1 Air filter

NOTICE

Each air filter must be secured by clamp attachment and a wire securing element. See chapt. 05-00-00 section: Acceptable methods, techniques and practice. Filter connection must be free of oil.

NOTICE

Attach new air filter, free of grease, at connection faces, and wire-secure against loss.

COOLING SYSTEM

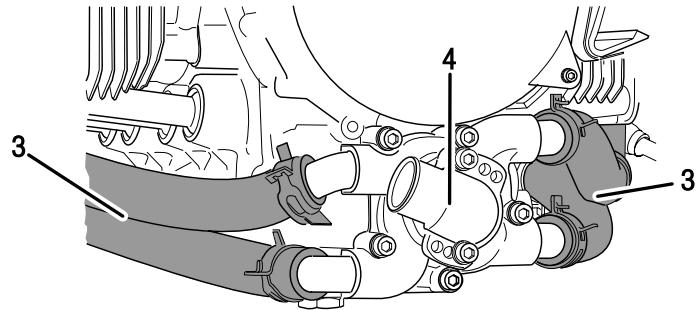
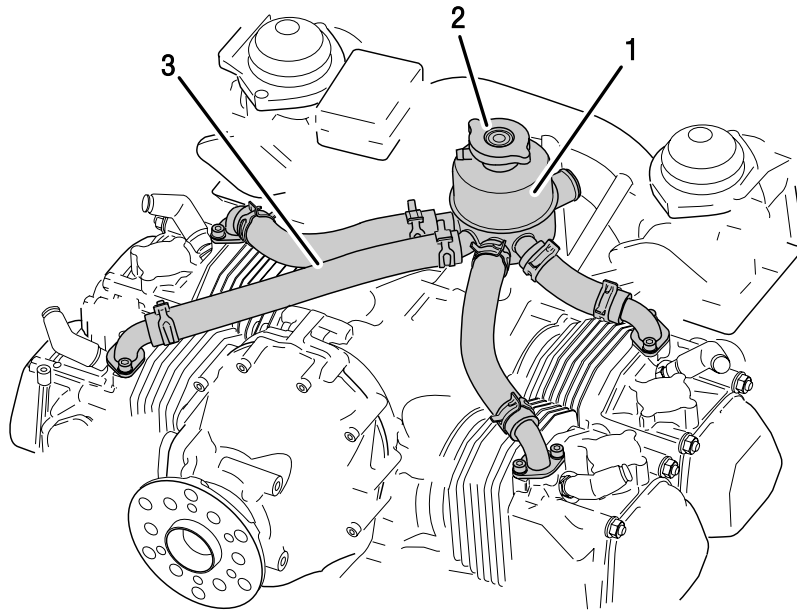

08532

Figure 7.13: Overview

- 1 Expansion tank
- 3 Coolant hose

- 2 Radiator cap
- 4 Water pump

BRP-Rotax MAINTENANCE MANUAL LINE

CHECKING THE COOLING SYSTEM

General note See Figure Overview.

⚠ WARNING

Risk of burns and scalds. Hot engine parts.
Always allow engine to cool down to ambient temperature before starting work.

⚠ WARNING

Non-compliance can result in serious injuries or death!

Any of the following conditions require a check of the cooling system/radiator cap check as described in Chapter 05-50-00 Unscheduled Maintenance.

- unusual high coolant temperatures (exceeded limits)
- reported unusual higher coolant consumption
- any visual signs of coolant leakages in the engine area
- high amount of deposits in the cooling system

NOTICE

If any component in the cooling system requires replacement, a check according to Chapter 05-50-00 Unscheduled Maintenance is recommended.

REPLACING THE COOLANT

General note

⚠ WARNING

Risk of Burns!
Never open the radiator cap when the cooling system is hot. For safety's sake, cover cap with a rag and open slowly. Sudden opening of the cap could provoke the escape of boiling coolant and result in scalding.

NOTICE

Use only coolant as recommended in the current Operators Manual (OM)

ENVIRONMENTAL NOTE

Protect the environment!
Do not harm the environment by spilling coolant. Dispose coolant in an environmentally friendly manner.

BRP-Rotax MAINTENANCE MANUAL LINE

Instruction

To replace the coolant the following steps are necessary:

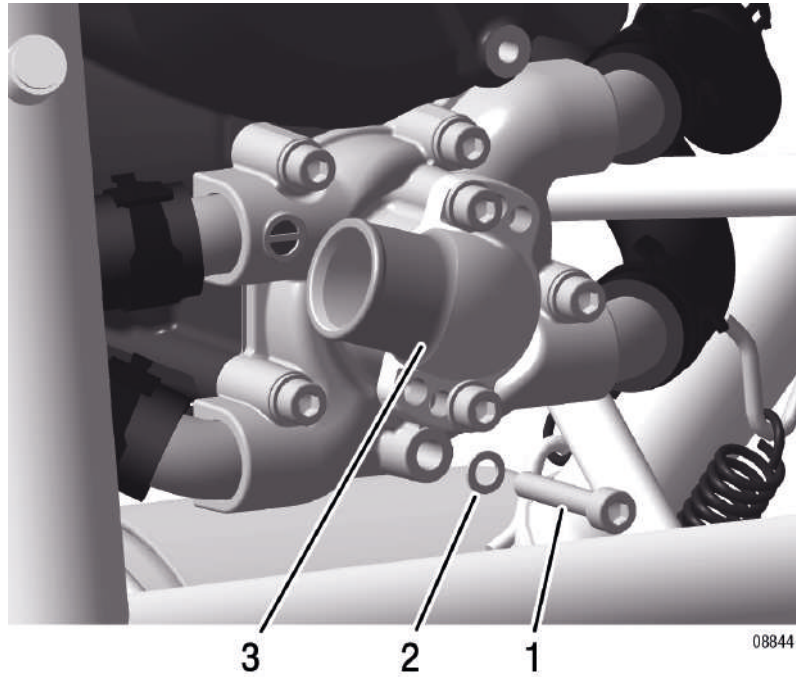

Figure 7.14: Replacing the coolant

- 1 Allen screw M6x35 (stainless)
- 2 Gasket ring
- 3 Water pump

Step	Procedure
1	Open the radiator cap on the expansion tank.
2	Remove the bottom Allen screw (1) (with sealing ring (2)) of water pump (3).
3	Drain the engine coolant. NOTE <i>If the radiator is located below the engine, also detach the lowest positioned coolant hose.</i>
4	Fit Allen screw (stainless steel) along with a new sealing ring. Tighten to 10 Nm (89 in.lb).
5	If the coolant is being replaced with a different type, (OAT, IAT) the cooling system must be flushed. See Chapter 12-20-00 section Flushing the cooling system.
6	Refill newly mixed coolant into the expansion tank (highest point of the cooling system). See Chapter 12-10-00 section Coolant check/replenish.

BRP-Rotax
MAINTENANCE MANUAL LINE

Step	Procedure
7	Fit radiator cap.
8	<p>NOTE</p> <p><i>Run the engine briefly and replenish with clean coolant as required.</i></p>

FLUSHING THE COOLING SYSTEM

General note

⚠ WARNING
<p>Risk of Burns!</p> <p>Never open the radiator cap when the cooling system is hot. For safety's sake, cover cap with a rag and open slowly. Sudden opening of the cap could provoke the escape of boiling coolant and result in scalding.</p>

Instruction

To flush the coolant the following steps are necessary:

Step	Procedure
1	Open the radiator cap on the expansion tank.
2	Open the lowest located coolant hose (either at water pump or radiator)
3	<p>Flush the system from the open expansion tank down to the open coolant hose using pure (alternative is distilled) water.</p> <p>NOTE</p> <p><i>It is recommended to use a pump for flushing of the cooling system with water under pressure.</i></p>
4	Let residual water drain and reconnect the lowest located coolant hose.
5	<p>Refill newly mixed coolant into the expansion tank (highest point of the cooling system).</p> <p>See Chapter 12-10-00 section Coolant check/replenish.</p>

NOTICE
<p>If water-free coolant is used, the cooling system must be flushed and refilled with conventional coolant.</p>

Step	Procedure
6	Fit radiator cap.
7	<p>NOTE</p> <p><i>Run the engine briefly and replenish with clean coolant as required.</i></p>

EXPANSION TANK, RADIATOR CAP

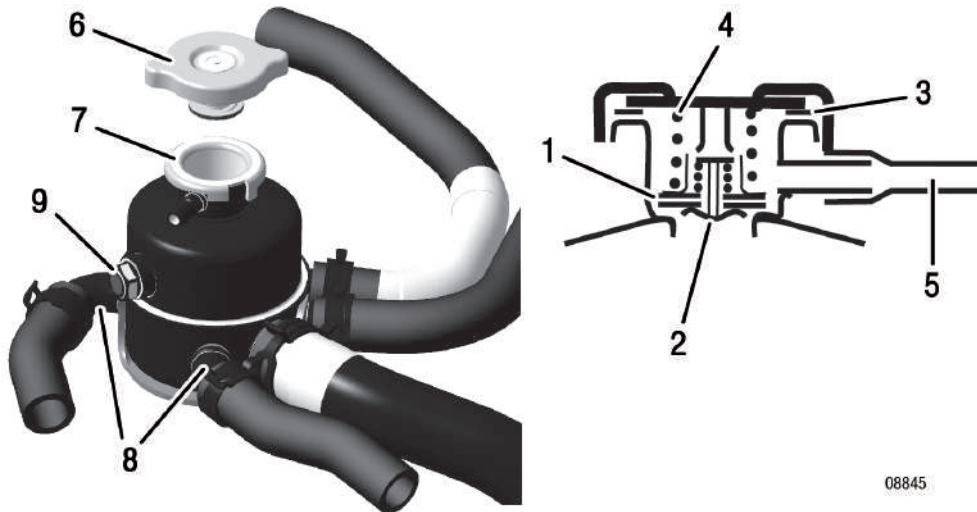

08845

Figure 7.15: Expansion tank, radiator cap

- | | | | |
|---|-------------------------------|---|--------------------------------------|
| 1 | Pressure relief valve | 2 | Return valve |
| 3 | Rubber seal | 4 | Pressure spring |
| 5 | Connection to overflow bottle | 6 | Opening pressure of the radiator cap |
| 7 | Sealing surface | 8 | Tube connections |
| 9 | Sight glass | | |

General note To equalize pressure in the cooling system, an expansion tank is required. If the pressure in the system rises above 1.2 bar (17.4 psi) as the coolant warms up, the pressure relief valve (1) opens and the coolant can flow into the overflow bottle via the line (5). When the coolant cools down, the return valve (2) opens and the coolant is sucked back.

Radiator cap Inspect the rubber seal (3), the pressure spring (4) and the two valves incorporated in the radiator cap for damage and leaks. If necessary, replace with a new original radiator cap (6) with 1.2 bar (17.4 psi) opening pressure.

NOTE

The radiator cap must be tightened fully on the expansion tank until the stop lug is contacted.

Expansion tank Inspect sealing surface (7) and tube connection (8) of the expansion tank. Carry out visual inspection of tank for damage and scuffing marks.

BRP-Rotax
MAINTENANCE MANUAL LINE

⚠ WARNING
Non-compliance can result in serious injuries or death!

OVERFLOW BOTTLE

General note

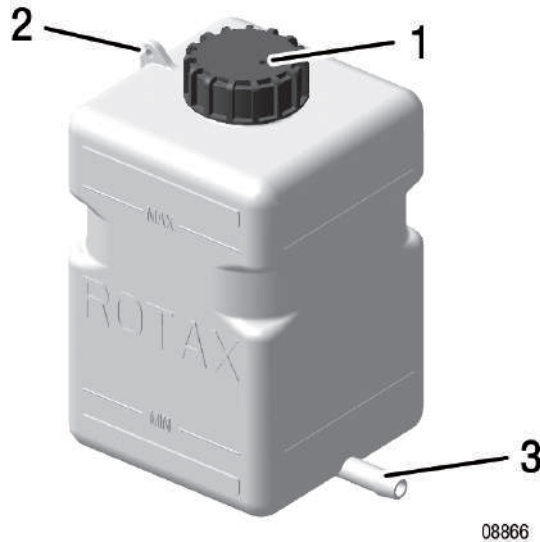

Figure 7.16: Overflow bottle

- 1 Venting bore
- 2 Tab for the safety wire
- 3 Hose connection

Instruction

Checking overflow bottle.

Step	Procedure
1	Inspect the bottle for damage.
2	Check the venting bore (1) in the screw cap.
3	Inspect tab (2) for the safety wire.
4	Check hose connection (3).

ACCESSORIES (INCLUDING RADIATOR, RADIATOR HOSES, HOSE CLAMPS, COOLING AIR DUCTS)

General note Accessories (including radiator, radiator hoses, hose clamps, cooling air ducts)

NOTICE
Equipment is to be inspected in accordance with the Maintenance Manual of the aircraft manufacturer.

BRP-Rotax
MAINTENANCE MANUAL LINE

FUEL SYSTEM

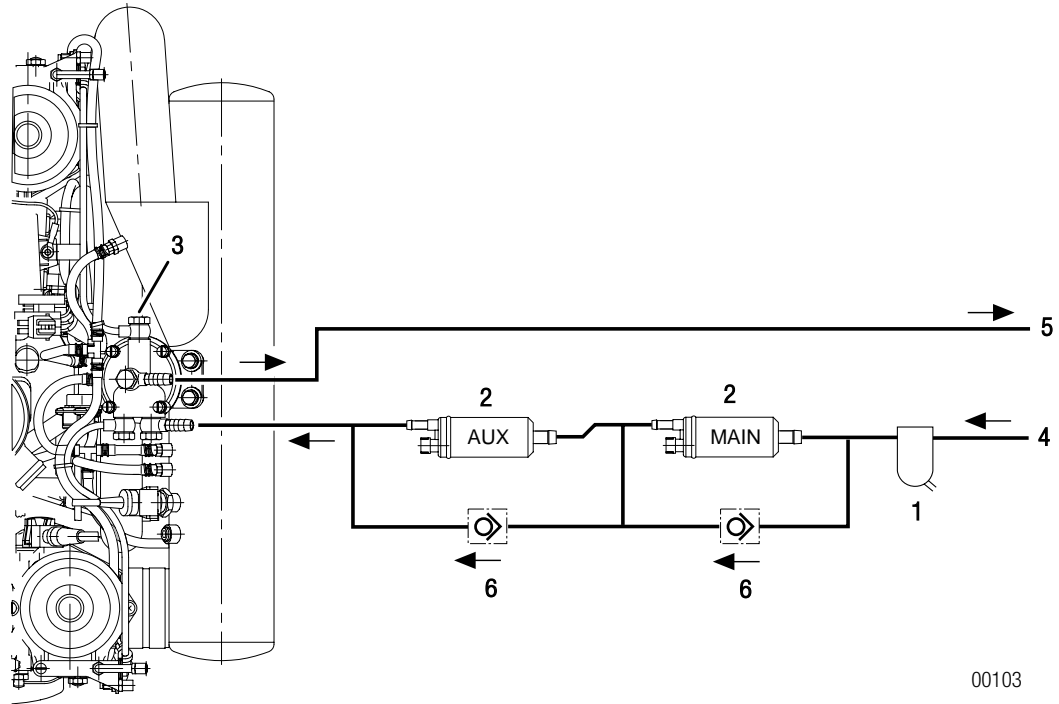

00103

Figure 7.17: Overview

- | | | | |
|---|----------------------------------|---|------------------------|
| 1 | Fine filter/watertrap gascolator | 2 | 2 x Electric fuel pump |
| 3 | Fuel pressure control | 4 | Feeding line from tank |
| 5 | Return line to tank | 6 | 2x Check valve |

BRP-Rotax
MAINTENANCE MANUAL LINE

CARBURETOR SYNCHRONIZATION

Idle speed

Checking the synchronization at idle speed

For smooth idling, synchronization of the throttle valves is necessary. When synchronizing, slacken both bowden cables (throttle lever lies close on the adjustment screw).

Instruction

To synchronize when idling the following steps are necessary.

Step	Procedure
1	Detach the resonator hose of the compensating tube to separate the two air intake systems. In this condition, a slight difference in the engine running should be noticeable.

NOTE

First carry out the mechanical synchronization and then the pneumatic synchronization (if required).

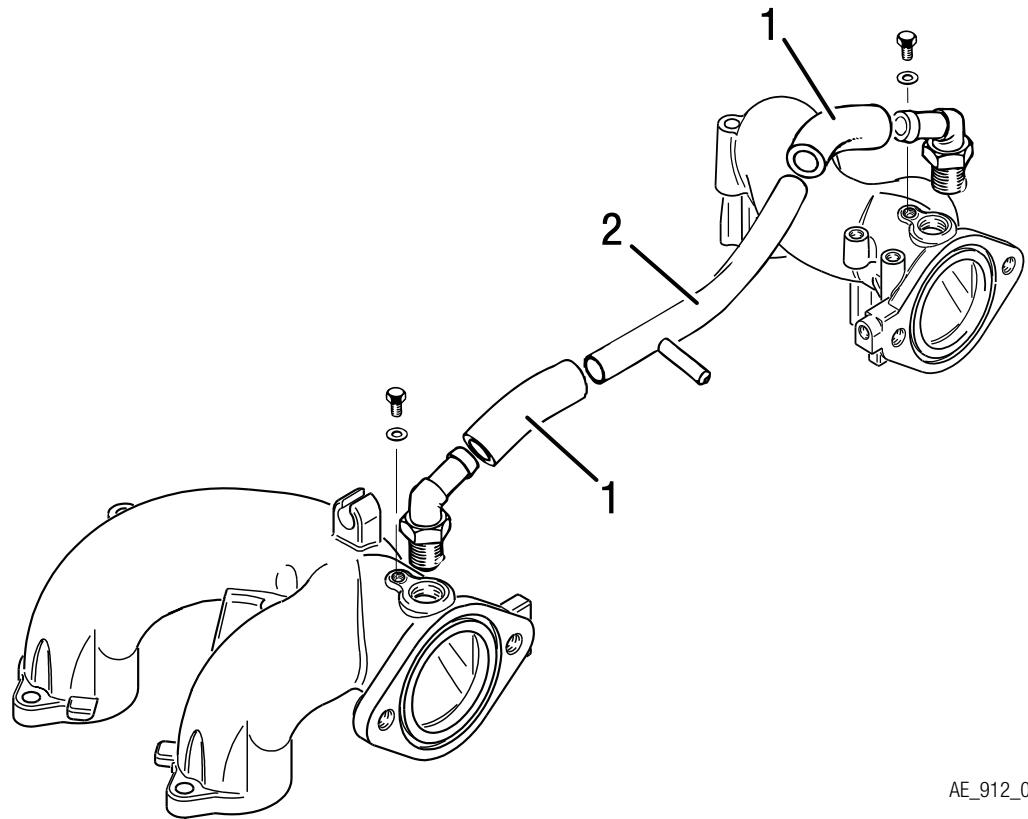

AE_912_0083

Figure 7.18: Synchronization at idle speed

1 Resonator hose

2 Compensating tube

BRP-Rotax

MAINTENANCE MANUAL LINE

MECHANICAL SYNCHRONIZATION

General note

⚠ WARNING

Non-compliance can result in serious injuries or death!
Always observe the engine from a safe place while it is running. Check that the cockpit is occupied by a competent operator.

Basic throttle adjustment

For synchronous basic throttle adjustment proceed as follows.

Step	Procedure
1	Remove cable fixation (4) on throttle lever (1).
2	Return the throttle lever (1) to its idle stop position (3) by hand. There should be no resistance during this procedure.
3	Unscrew idle speed adjustment screw (2) until it is free of the stop.
4	Insert a 0.1 mm (0.004 in.) feeler gauge (gap X) between the idle speed adjustment screw (2) and the carburetor idle stop (3), then gently turn the idle screw clockwise until contact is made with the 0.1 mm (0.004 in.) feeler gauge.
5	Pull out the feeler gauge and then turn each idle speed adjustment screw (2) 1.5 turns clockwise.
6	Gently turn each idle mixture screw (6) (clockwise) until it is fully inserted and then reopen by 1.5 turns counter clockwise.
7	Check that the throttle valve opens fully automatically.
8	Adjust the two bowden cables for simultaneous opening of the throttle valves.

Carry out the above procedure on both carburetors.

Synchronization

You must at this point place the throttle lever in the cockpit to the idle stop position. It is an advantage at this point to enlist the help of an assistant to ensure that the throttle lever remains in this position during the next steps of the synchronization process.

Step	Procedure
1	As soon as the throttle lever in the cockpit remains in the idle stop position, check the throttle valve lever to the carburetor idle stop position.
2	Using the cable fixation, secure the bowden cable accordingly.
3	As soon as the two carburetor bowden cables are installed (throttle lever in cockpit in idle position), you must check that the idle speed adjustment screw rests fully on the idle stop without pressure.

BRP-Rotax MAINTENANCE MANUAL LINE

NOTICE

An idle speed which is too low can result in gearbox wear, and if the idle speed is too high, the engine is harder to start.

Step	Procedure
4	Start the engine and verify the idle speed. If the idle speed is too high or too low, adjust accordingly with idle speed adjustment screw.
5	Check the true running of the engine. If necessary, adjust with the idle mixture screw.

Carry out the above procedure on both carburetors.

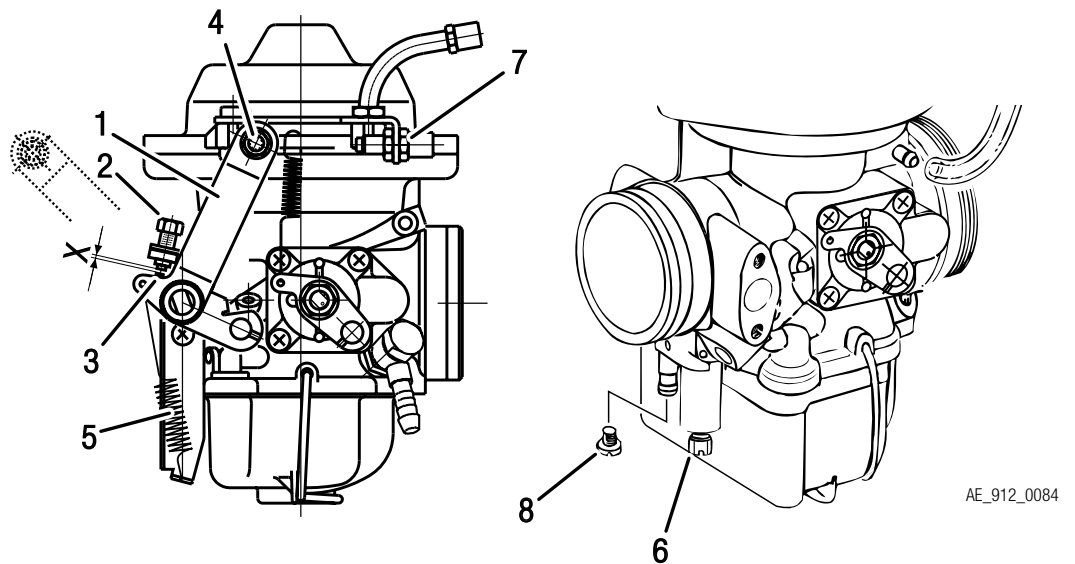

Figure 7.19: Mechanical synchronization

- | | |
|--|---|
| <ul style="list-style-type: none"> 1 Throttle valve lever 2 Adjustment screw 3 Idle stop position 4 Cable fixation 5 Return spring 6 Idle mixture screw 7 Idle adjustment | <ul style="list-style-type: none"> 8 Plug screw M3.5x5 |
|--|---|

PNEUMATIC SYNCHRONIZATION

General note

⚠ WARNING

Non-compliance can result in serious injuries or death!
Always observe the engine from a safe place while it is running. Check that the cockpit is occupied by a competent operator.

BRP-Rotax MAINTENANCE MANUAL LINE

NOTE

Perform a mechanical synchronization before attempting a pneumatic synchronization.

Special tool

The two carburetors are adjusted to equal flow rate at idling with a suitable flow meter or vacuum gauge(s).

Connection

Possible connection methods.

Option 1	
Step	Procedure
1	Remove the compensating tube (2) from the push on angular tube (4) after removing the two clamps.
2	Using the push on angular tube (4) and compensating tube (2) install a flexible rubber hose (5) leading to the vacuum gauge (1).

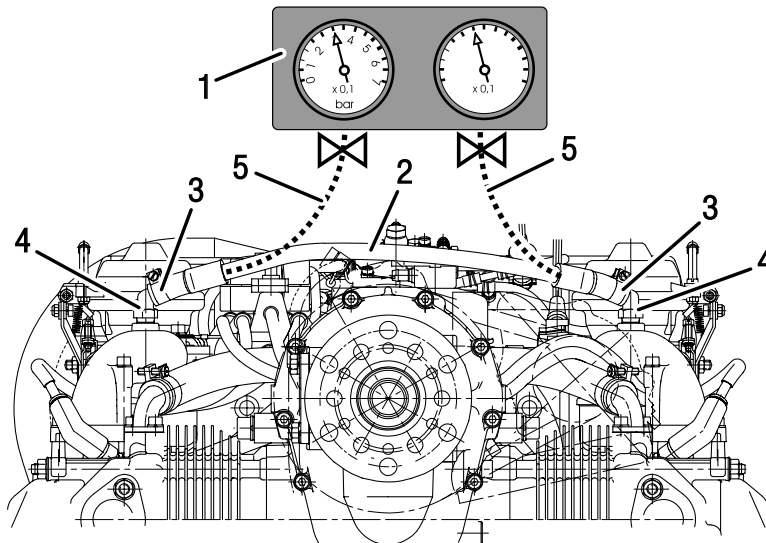

AE_912_0085

Figure 7.20: Option 1

- | | |
|----------------|---------------------|
| 1 Vacuum gauge | 2 Compensating tube |
| 3 Clamp | 4 Angular tube |
| 5 Rubber hose | |

BRP-Rotax MAINTENANCE MANUAL LINE

Option 2	
Step	Procedure
1	Remove one end of the compensating tube (2) and tube from the push on angular tube (5) after removing the two tension clamp (4).
2	Using the push on angular tube (5) and compensating tube (2) install a flexible rubber hose (6) leading to the vacuum gauge (1).

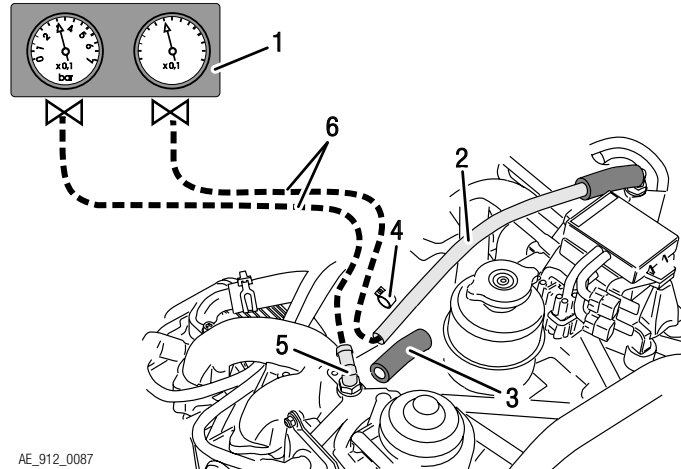
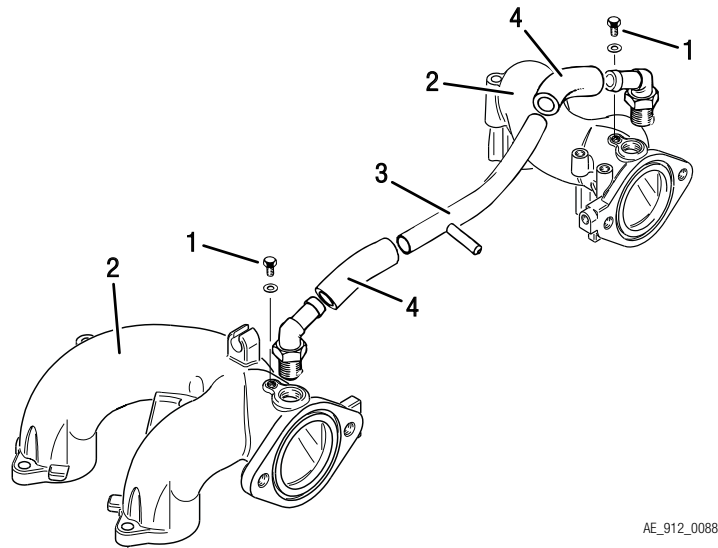

Figure 7.21: Option 2

- | | |
|----------------|---------------------|
| 1 Vacuum gauge | 2 Compensating tube |
| 3 Tube | 4 Clamp |
| 5 Angular tube | 6 Rubber hose |

Option 3	
Step	Procedure
1	Remove hex. screw M6x6 from intake manifold and connect the vacuum gauge.
2	Remove the compensation hose with attached resonator hose (connection between intake manifolds) and plug the fittings in the intake manifolds.
3	After synchronization, tighten the screw M6x6 with LOCTITE 243.

BRP-Rotax
MAINTENANCE MANUAL LINE



AE_912_0088

Figure 7.22: Option 3

- | | | | |
|---|-------------------|---|-----------------|
| 1 | Hex. screw M6x6 | 2 | Intake manifold |
| 3 | Compensation tube | 4 | Resonator hose |

Option 4	
Step	Procedure
1	Install the vacuum gauge.
2	Clamp tube (2) with clamping pliers (1). on the cylinder 1/3 side. The compensation tube (3) does not have to be removed.
3	Remove the screw (4).
4	Install the hose nipple M6 (5) with sealing ring (6).
5	After synchronization tighten the screw M6x6 with LOCTITE 243.

BRP-Rotax MAINTENANCE MANUAL LINE

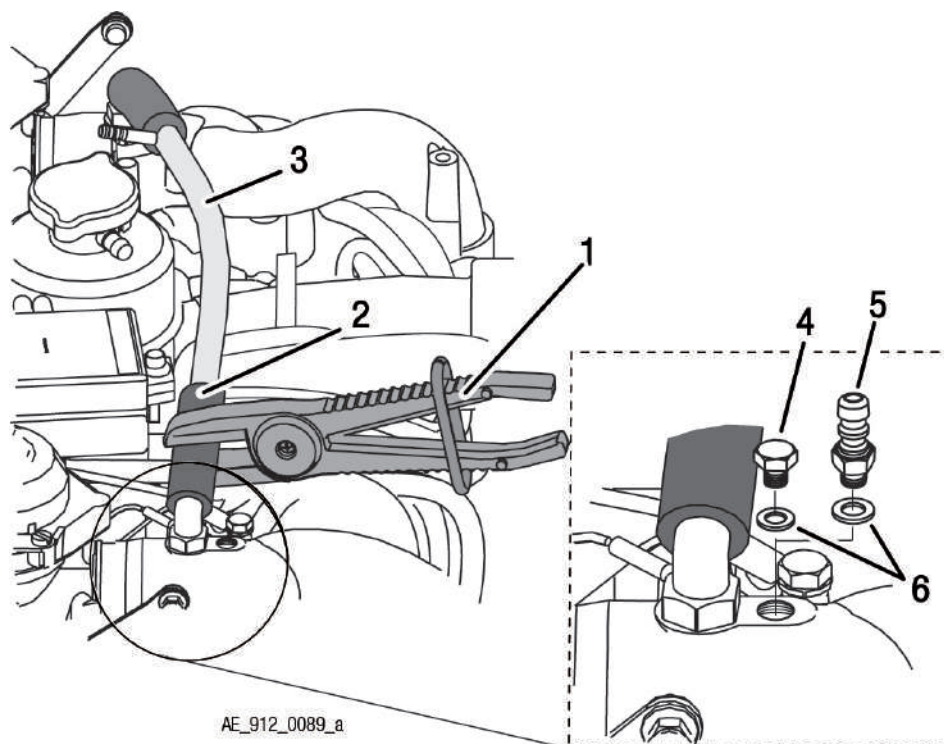

Figure 7.23: Option 4

- | | | | |
|---|-------------------|---|-------------------------|
| 1 | Clamping pliers | 2 | Hose, Cylinder 1/3 side |
| 3 | Compensation tube | 4 | Screw |
| 5 | Hose nipple | 6 | Sealing ring |

IDLE SPEED CHECK

General note Before proceeding, secure the aircraft on the ground using wheel chocks and ropes.

⚠ WARNING

Non-compliance can result in serious injuries or death!
Secure the propeller region before test run watch it. Secure a safe area around propeller during test run.

Start the engine and verify the idle speed. If necessary correct as per Chapter 12–20–00 section Idle speed adjustment

Setting of more than 1/2 turn

If a setting of more than 1/2 turn is required, repeat mechanical synchronization to prevent too high a load on the idle stops. If the idle speed is too high, the maximum the idle screw can be unscrewed is complete turn.

BRP-Rotax MAINTENANCE MANUAL LINE

No satisfactory result

If an unsatisfactory result is achieved, inspect the idle jets for contamination and clean if necessary.

NOTICE

Also check for translucent, jelly-like contamination. Inspect for free passage.

OPERATING RANGE CHECK

General note

Once the proper idling speed has been established, it is necessary to check the operating range above the idle speed.
First establish that the engine is developing full take-off performance or take-off rpm when selected in the cockpit. Then the setting of the operating range (idle to full throttle) can be checked or adjusted.

Procedure

To control the operating range above idling the following steps are necessary.

Step	Procedure										
1	<p>Start and warm up engine (See Operators Manual). Select full power and check that both pressure gauges are registering the same readings. If the same reading is not made on both gauges.</p> <table border="1" style="width: 100%; border-collapse: collapse; margin-top: 5px;"> <thead> <tr style="background-color: #D3D3D3;"> <th style="width: 10%;">Step</th> <th>Procedure</th> </tr> </thead> <tbody> <tr> <td style="text-align: center;">1</td> <td>Shut down the engine.</td> </tr> <tr> <td style="text-align: center;">2</td> <td>Check that carburetor actuation effects full travel and that starting carburetors (choke) are in the full off position.</td> </tr> <tr> <td style="text-align: center;">3</td> <td>If necessary, fit/modify the carburetor actuation as required to achieve full power on both carburetors.</td> </tr> </tbody> </table>	Step	Procedure	1	Shut down the engine.	2	Check that carburetor actuation effects full travel and that starting carburetors (choke) are in the full off position.	3	If necessary, fit/modify the carburetor actuation as required to achieve full power on both carburetors.		
Step	Procedure										
1	Shut down the engine.										
2	Check that carburetor actuation effects full travel and that starting carburetors (choke) are in the full off position.										
3	If necessary, fit/modify the carburetor actuation as required to achieve full power on both carburetors.										
2	<p>Once full power has been established on both carburetors, retard the throttle and observe the pressure gauge settings. The pressure gauges should show the same reading for both carburetors.</p> <p>NOTE</p> <p><i>Discrepancies must be compensated for by adjusting the off idle adjustment.</i></p> <table border="1" style="width: 100%; border-collapse: collapse; margin-top: 5px;"> <thead> <tr style="background-color: #D3D3D3;"> <th style="width: 10%;">Step</th> <th>Procedure</th> </tr> </thead> <tbody> <tr> <td style="text-align: center;">1</td> <td>Shut down the engine.</td> </tr> <tr> <td style="text-align: center;">2</td> <td>Loosening the locknut on the bowden cable and adjusting the off idle adjustment.</td> </tr> <tr> <td style="text-align: center;">3</td> <td>Tightening the locknut.</td> </tr> <tr> <td style="text-align: center;">4</td> <td>Re-testing the engine.</td> </tr> </tbody> </table>	Step	Procedure	1	Shut down the engine.	2	Loosening the locknut on the bowden cable and adjusting the off idle adjustment.	3	Tightening the locknut.	4	Re-testing the engine.
Step	Procedure										
1	Shut down the engine.										
2	Loosening the locknut on the bowden cable and adjusting the off idle adjustment.										
3	Tightening the locknut.										
4	Re-testing the engine.										

BRP-Rotax MAINTENANCE MANUAL LINE

Step	Procedure
3	Final idle speed adjustment may be required by resetting the idle speed adjustment screws.
4	Equal adjustment must be made on both carburetors.
5	Any major adjustments required necessitate replaced verification of all parameters mentioned in this procedure.

Assembly

NOTICE

Obey the manufacturers instructions!

- Install compensation tube assy. on engine in reverse sequence of removal. Any minor differences in balance at idle speed will be compensated for.
- Refit the screw plug M3.5 (3) and hex. screws M6x6 with gasket.

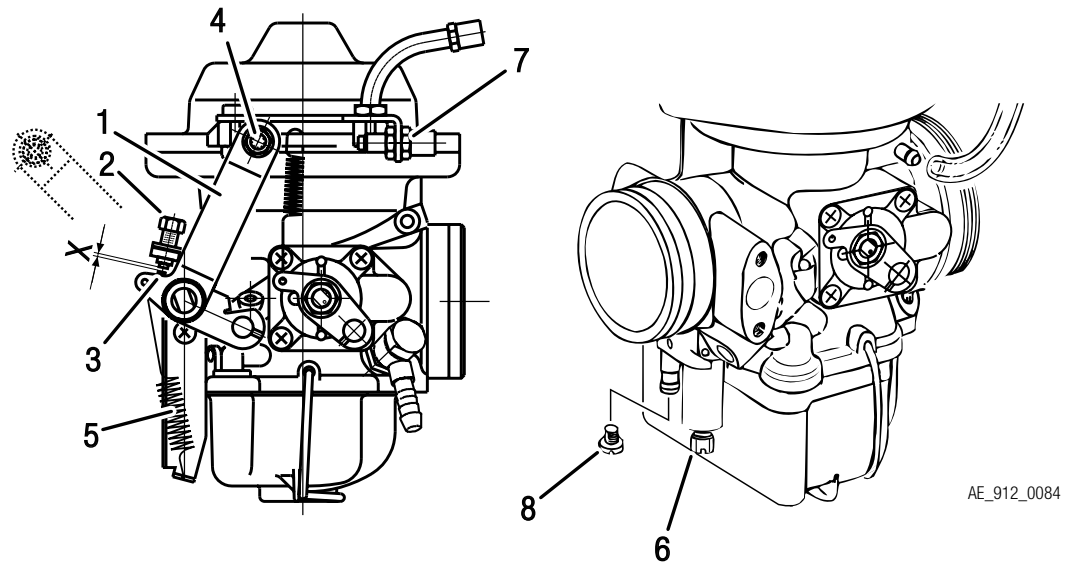

Figure 7.24: Inspect operating range/idle speed

- | | |
|------------------------|----------------------|
| 1 Throttle valve lever | 2 Adjustment screw |
| 3 Idle stop position | 4 Cable fixation |
| 5 Return spring | 6 Idle mixture screw |
| 7 Idle adjustment | 8 Plug screw M3.5x5 |

BRP-Rotax
MAINTENANCE MANUAL LINE

CHECKING OF THE FLOAT CHAMBER

General note

⚠ WARNING

Danger of severe burns and scalds! Always allow the engine to cool down to ambient temperature before starting any work.

Instruction

To check of the float chamber the following steps are necessary. See Figure: [Float chamber](#).

Step	Procedure
1	Remove drip tray (1).
2	Open spring clip (2).
3	Remove float chamber (3) with gasket (4) and both floats.
4	Remove both floats (5) from the float chamber.
5	Accomplishment of section "Check of weight of the floats."
6	Inspect the float chamber for contamination and corrosion.

NOTICE

If any contamination on float chamber the find out what the cause is and take corresponding action to rectify the problem. Inspect and clean the complete fuel system including carburetor.

Step	Procedure
7	Assembly at the float chamber should be carried out in reverse of steps 3.
8	Adjust with the idle speed adjustment. See Chapter 12-20-00 section Idle speed adjustment.

BRP-Rotax
MAINTENANCE MANUAL LINE

CHECK THE WEIGHT OF FLOATS

The weight inspection shows whether the affected floats have absorbed fuel. This is only significant if the floats already had contact with fuel.

NOTE

This check is not relevant for new spare parts, that were not in contact with fuel.

Step	Procedure
1	Let the floats dry for 1-2 minutes, then weigh the floats. Only weigh dry floats.
2	Check the weight of all affected floats using a calibrated scale. Measuring tolerance of the scale: max. 0.1 grams.
3	The results of the measurement must be documented in the maintenance records. The max. allowable weight (of both floats together) is 7 grams.

NOTICE

Replace all floats which exceed the max. weight.

BRP-Rotax
MAINTENANCE MANUAL LINE

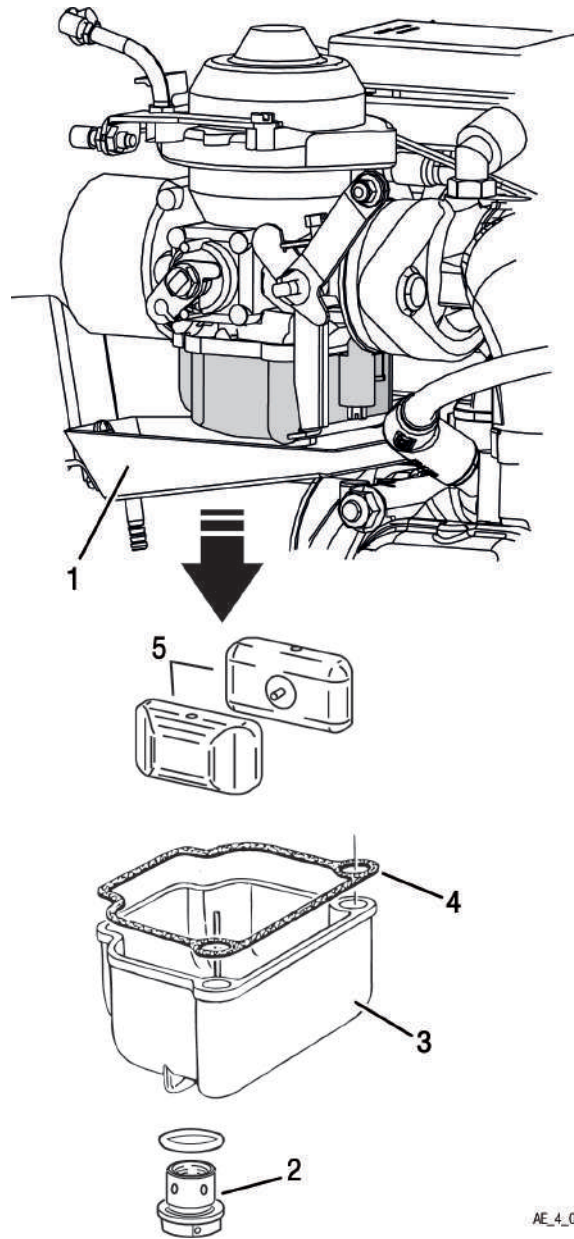

AE_4_0217

Figure 7.25: Float chamber

BRP-Rotax
MAINTENANCE MANUAL LINE

IDLE SPEED ADJUSTMENT

General note

NOTICE

IF satisfactory idle speed adjustment cannot be achieved, inspection of the idle jet or additional pneumatic synchronization will be necessary.

See Chapter 12-20-00 section Pneumatic synchronization.

Idle adjustment

Always carry out idle speed adjustment when the engine is warm.

- Basic adjustment of the idle speed is first effected using the idle speed adjustment screw of the throttle valve. See Chapter 12-20-00 section Mechanical synchronization.

Optimizing engine running

Necessary only if not taken care of at synchronization.

Step	Procedure
1	Close idle mixture screw by turning clockwise to screw in fully and then opening again by 1.5 turns counter clockwise.
2	Starting from this basic adjustment, the idle mixture screw is turned until the highest idle speed is reached.
3	The optimum setting is the middle between the two positions at which an rpm. drop is noticed.
4	Then readjustment of the idle speed is carried out using the idle speed adjustment screw and if necessary, by slightly turning the idle mixture screw again. NOTE <i>Turning the idle mixture control screw in clockwise direction results in a leaner mixture and turning counter clockwise in a richer mixture.</i>

BRP-Rotax MAINTENANCE MANUAL LINE

CHECKING THE CARBURETOR ACTUATION

General note Route bowden cables in such a way that carburetor actuation will not be influenced by any movement of engine or airframe, thus possibly falsifying idle speed setting and synchronization.

NOTE

Each carburetor is actuated by two bowden cables. At position connection for throttle valve, and at position connection for choke actuation.

⚠ WARNING

Non-compliance can result in serious injuries or death!

Use Bowden cable with minimized friction so that the spring on the throttle can open the throttle completely. Otherwise increase pretension of spring by bending lever flap or fit a stronger return spring, or a cable with pull-push action would have to be used. Secure the bowden cable sleeves in the adjustment screws (e.g. safety wire).

⚠ WARNING

Risk of life threatening injuries caused by propeller!

With carburetor actuation not connected, the throttle valve is fully open. The initial position of the CD carburetor is full throttle! So never start the engine with the actuation disconnected.

Procedure

To test the carburetor actuation the following steps are necessary:

Step	Procedure
1	Inspect bowden cables and levers for free movement.
2	Bowden cable must allow full travel of lever from stop to stop.
3	Adjust throttle cables to a clearance of 1 mm (0.04 in).
4	Inspect and lubricate linkage on carburetor and carburetor joints with engine oil.
5	Inspect return springs and inspect engagement holes for wear.

BRP-Rotax
MAINTENANCE MANUAL LINE

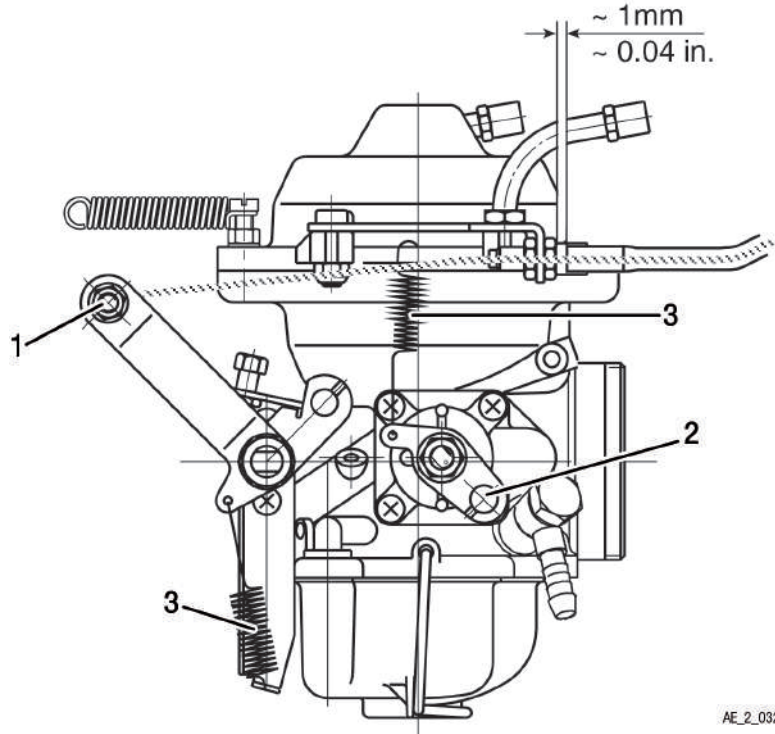

AE_2_0326

Figure 7.26: Checking the carburetor actuation

- 1 Connection for throttle valve
- 2 Connection for throttle valve
- 3 Return spring

LEAK TESTS

General note

NOTICE

Avoid over-tightening the fasteners. Use a suitable torque wrench for all work.

Instruction

To check the following steps are necessary:

Step	Procedure
1	Inspect all fuel lines, their connections and unions.
2	Inspect the fuel lines for sign of chafing.

CHECKING THE FUEL LINES

General note

See [Chapter 05–10–00 section Time limit for parts.](#)

BRP-Rotax MAINTENANCE MANUAL LINE

Instruction	Step	Procedure
	1	Inspect all hoses for porosity and other damage in particular at the hose clamps and connections and replace as required.
	2	Check fuel line (of steel).

FUEL PUMPS

General note



Inspect the fuel pumps in accordance with the manufacturers instructions or the aircraft manufacturers.

- Remove the housing
- Visual inspection of lines and connections

INSPECTION OF THE FUEL FILTER IN THE AIRFRAME

In the fuel supply line between the fuel tank (and the feed to the two fuel pumps must be a filter gascolater.

NOTICE

The fine filter is not included in delivery from BRP-Rotax. The aircraft manufacturer is responsible for the selection and the correct installation of the fine filter.

NOTE

The filter can be in a configuration as filter/water trap (gascolator).

Inspect this fine filter as described in the Aircraft Maintenance Schedule.

Fine filter fuel pump

If the filter in the airframe is heavily soiled, the two fine filters (4) integrated in the fuel pumps must also be inspected. See Chapter 73-00-00 Maintenance Manual Heavy (MMH).

CHECK VALVES

General note Check for leaks.

FUEL RAIL

General note Check for leaks.

BRP-Rotax
MAINTENANCE MANUAL LINE

LUBRICATION

Overview

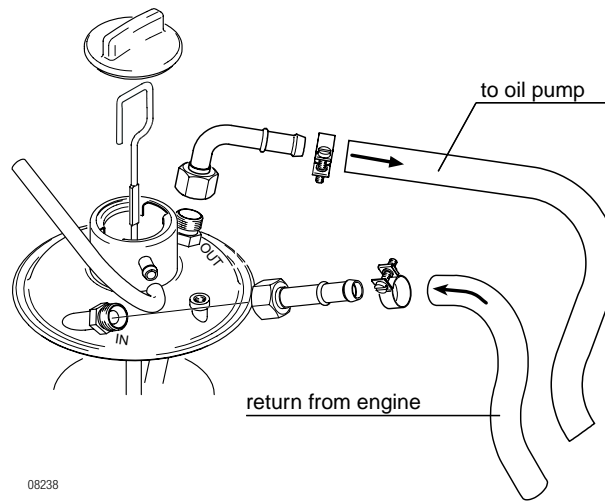

08238

Figure 7.27

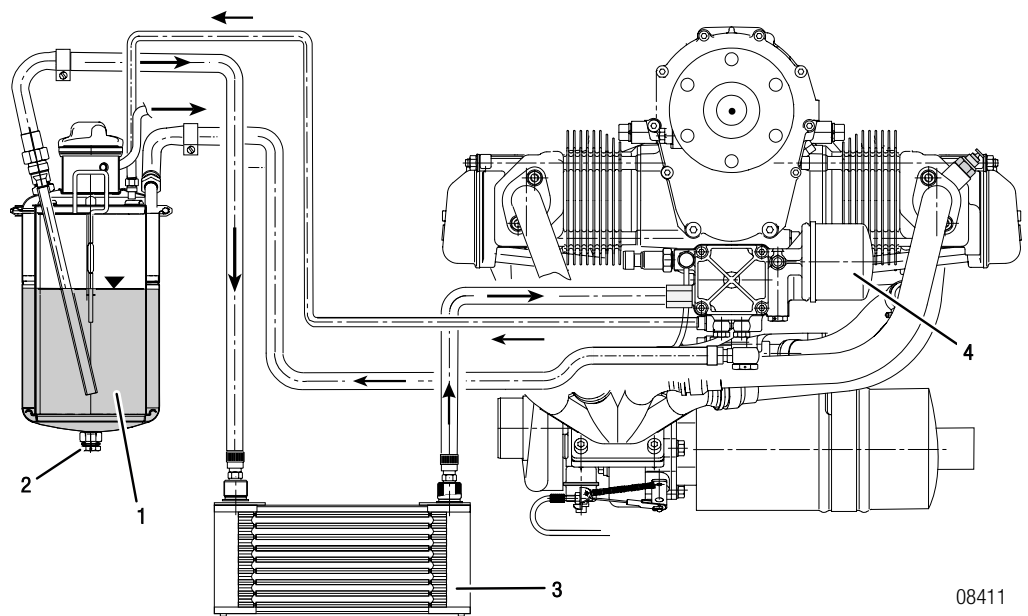

08411

Figure 7.28

- 1 Oil tank
- 2 Drain screw M12x12
- 3 Oil radiator
- 4 Oil filter

BRP-Rotax
MAINTENANCE MANUAL LINE

⚠ WARNING

Risk of burns and scalds. Hot engine parts.

Always allow engine to cool down to ambient temperature before starting work.

⚠ WARNING

Risk of electric shock!

Ignition "OFF" and system grounded! Disconnect negative terminal of battery.

NOTE

It is advisable to check the oil level prior to an oil change as it informs about oil consumption.

See [Chapter 12-10-00 section Oil level check/Replenish](#).

Observe

NOTICE

Observe the following to prevent possible unintentional voiding of the oil system and damage to the valve drive:

- Draining the suction lines, oil cooler and return line is not necessary and must be avoided, as it results in air entering the oil system.
See [Chapter 12-20-00 section Purging the oil system](#).
- Replacement of the oil filter and the oil change should be effected quickly and without interruption to prevent a draining of the oil system and the hydraulic tappets.

BRP-Rotax
MAINTENANCE MANUAL LINE

OIL CHANGE

Instruction

NOTE

Run engine to warm oil before beginning oil change procedure. To change the oil the following steps are necessary:

NOTICE

Counter the hex nut of the oil tank when loosening and/or torquing the oil drain screw to avoid stress in the soldering.

Step	Procedure
1	Crank engine slowly by hand to transfer the oil from the crankcase. See Chapter 12-10-00 section Oil level check/Replenish .
2	Remove safety wire and oil drain screw from the oil tank, drain the used oil - see environment note.
3	Replace oil filter at each oil change, cut open and inspect the filter components. See Chapter 12-20-00 section Oil filter replacement and Inspection of the filter insert .
4	Dispose of oil filter according to environmental regulations.
5	Install oil drain screw with new gasket and safety wire (tightening torque 25 Nm (18 ft. lb)).

NOTICE

Only use brand name oil in accordance with the latest Operators Manual (OM) and the latest Service Instruction "Selection of suitable operating fluids" of the respective engine type.

NOTICE

The engine must not be cranked when the oil system is open. Attention must also be paid to this before first commissioning (e.g. when assembling the propeller after correct purging of the oil system).

BRP-Rotax
MAINTENANCE MANUAL LINE

NOTICE

DO NOT use compressed air to blow through the oil system (or oil lines, oil cooler, oil pump housing, oil bores in the engine).

ENVIRONMENTAL NOTE

Protect the environment.

Do not harm the environment by spilling oil. Dispose of oil in an environmentally friendly manner.

Step	Procedure
6	Install new oil filter.
7	Pour in approx. 3 l (0.8 gal (US)) of fresh oil.
8	After carrying out the oil change, the engine should be slowly cranked by hand in the direction of engine rotation (approx. 20 turns) to completely refill the entire oil circuit.

OIL FILTER REMOVING

General note

⚠ WARNING

Risk of burns and scalds. Hot engine parts.

Always allow engine to cool down to ambient temperature before starting work.

NOTICE

To ensure functioning of the oil circuit and the forced flow lubrication, use oil filter only. Only these filters will ensure correct pressure in the by-pass valve.

At every oil change, unscrew the oil filter and cut open using special tool taking care not to produce chips.

Special tools

To carry out the procedure the following tools are necessary:

part number	Description
part no. 877620*	(1) Oil filter wrench
part no. 276275*	(2) Cutting tool
* or equivalent	

BRP-Rotax
MAINTENANCE MANUAL LINE

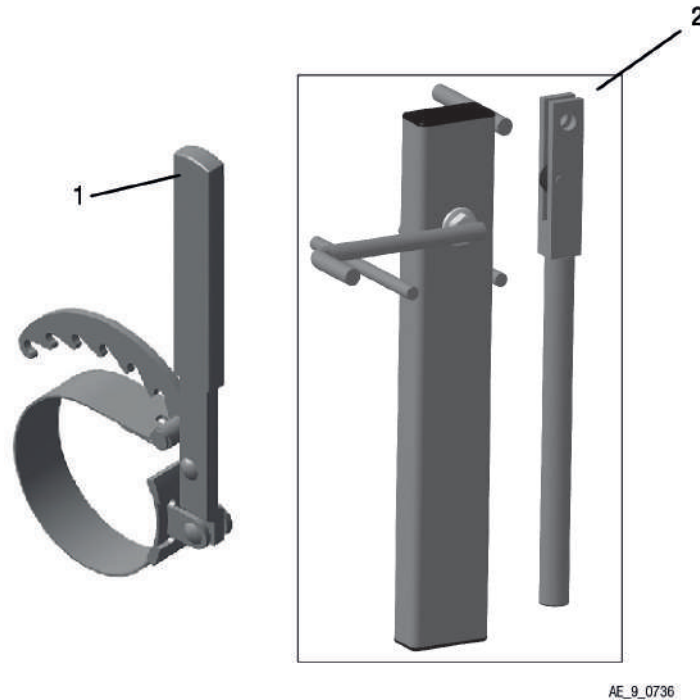

Figure 7.29: Special tool

1 Oil filter wrench part no. 877620*

2 Cutting tool part no. 276275

**or equivalent*

Procedure

To remove the oil filter the following steps are necessary:

Step	Procedure
1	Remove used oil filter with oil filter wrench.
2	Clean the contact surface of the oil pump housing with a clean cloth.

INSPECTING OF THE OIL FILTER COMPONENTS

General note

NOTICE

The filter components must be inspected carefully.

This inspection is important as it allows conclusions to be drawn regarding the internal condition of the engine and provides information about the possible cause of any damage.

Procedure

To carry out the procedure the following steps are necessary:

BRP-Rotax
MAINTENANCE MANUAL LINE

Step	Procedure
1	Oil filter cut open using special tool taking care not to produce chips.
2	Remove anti-drain membrane.
3	Cut top and bottom edges off the mat with a knife.
4	Remove filter mat, fold up and press remaining oil out.
5	Unroll and inspect it for metal chips, foreign matter, contamination and abrasion.
6	Pass over matt with a clean magnet and inspect for metal.

Possible foreign matter

Steel chips	Bronze chips
Aluminium chips	Sliver of bearing material
Remains of sealing compound	Plastic (thrust washer)
Carbon fiber	Sliver or copper LOCTITE Anti Seize

Increased foreign matter

If an increased amount of metal particles is found, such as brass- or bronze chips or sliver from bearing abrasion, repair or overhaul the engine in accordance with the BRP-Rotax instructions for continued airworthiness. If the filter mat is clogged by foreign matter, the lube oil reaches the bearing points unfiltered via the by-pass valve in the oil filter.

Unclear findings

In the case of unclear findings:

Step	Procedure
1	Flush the oil circuit.
2	Fit a new oil filter.
3	Engine test run. See Chapter 12-20-00 section: Test run of engine.
4	Inspect the oil filter once more.

BRP-Rotax MAINTENANCE MANUAL LINE

Contaminated

NOTICE

If the oil circuit is contaminated, replace the oil cooler and flush the oil circuit. See Chapter 12-20-00 section: Flushing the oil circuit. Proper judgement requires years of experience in repair of piston engines.

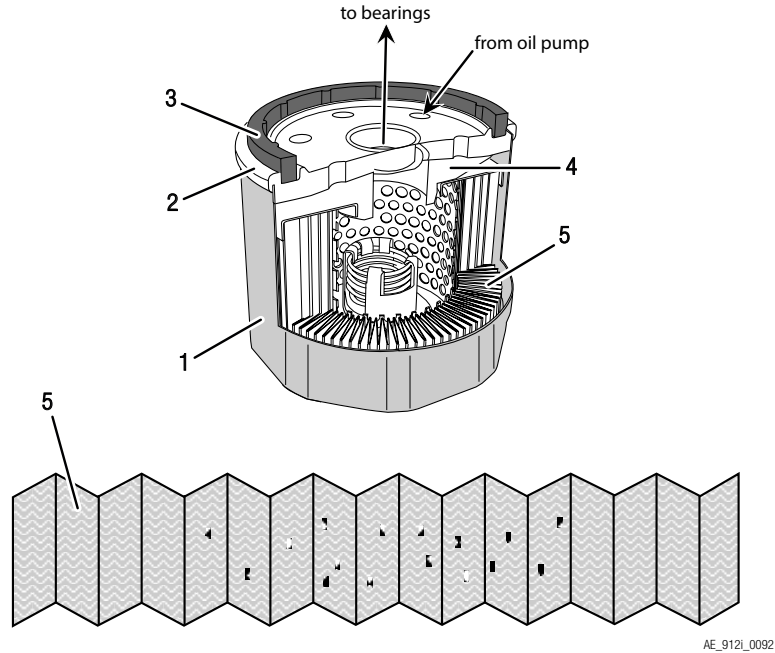

Figure 7.30: Oil filter

- | | |
|--|---|
| <ul style="list-style-type: none"> 1 Filter housing 3 Gasket ring 5 Filter matt | <ul style="list-style-type: none"> 2 Filter cover 4 Anti-drain membrane |
|--|---|

INSTALLING NEW OIL FILTER

Procedure To mount the oil filter the following steps are necessary:

Step	Procedure
1	Clean the contact surface (1) of the oil pump housing (2) with a clean cloth.
2	Apply thin film engine oil on the gasket (3) of the oil filter (4).
3	Install the oil filter on the engine.
4	Screw on oil filter until oil filter gasket is seated solidly.

BRP-Rotax
MAINTENANCE MANUAL LINE

Step	Procedure
	NOTE <i>Mark 270° - check mark on oil pump housing to control tightening of oil filter.</i>
5	Tighten oil filter with 3/4 turn (270°).
6	Inspection of the used oil filter. See Chapter 12-20-00 section Inspection of the filter insert .

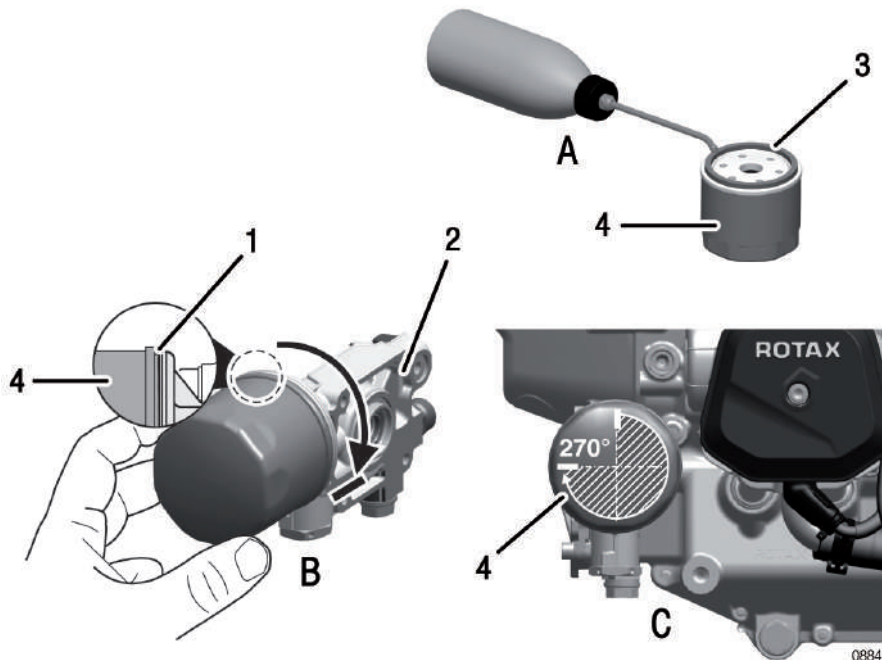

Figure 7.31: Install oil filter

BRP-Rotax
MAINTENANCE MANUAL LINE

CLEANING THE OIL TANK

General note **NOTE**

This procedure is optional and requires purging of the oil system. See [Chapter 12-20-00 section Purging the oil system](#). If using leaded fuel it is required to clean the tank every 200 flight hours. It is only necessary to clean the oil tank and the inner parts if there is heavy oil contamination.

Procedure Procedure to clean the oil tank:

Step	Procedure
1	Detach the profile clamp (2) and remove the oil tank cover (3) together with the O-ring (4) and the oil lines.
2	Remove the inner parts of the oil tank such as the baffle insert (5) and the partition (6).
3	Clean oil tank (8) and inner parts (5,6) and check for damage.

NOTICE

Incorrect assembly of the oil tank components might cause engine faults or engine damage.

Step	Procedure
4	Fit hex. screw (1) M12x12 with a new gasket ring (7). Tighten to 25 Nm (18 ft.lb).
5	Safety wire (9).
6	Reassemble the oil tank by following the same steps in reverse order.
7	Purge the oil system.

BRP-Rotax
MAINTENANCE MANUAL LINE

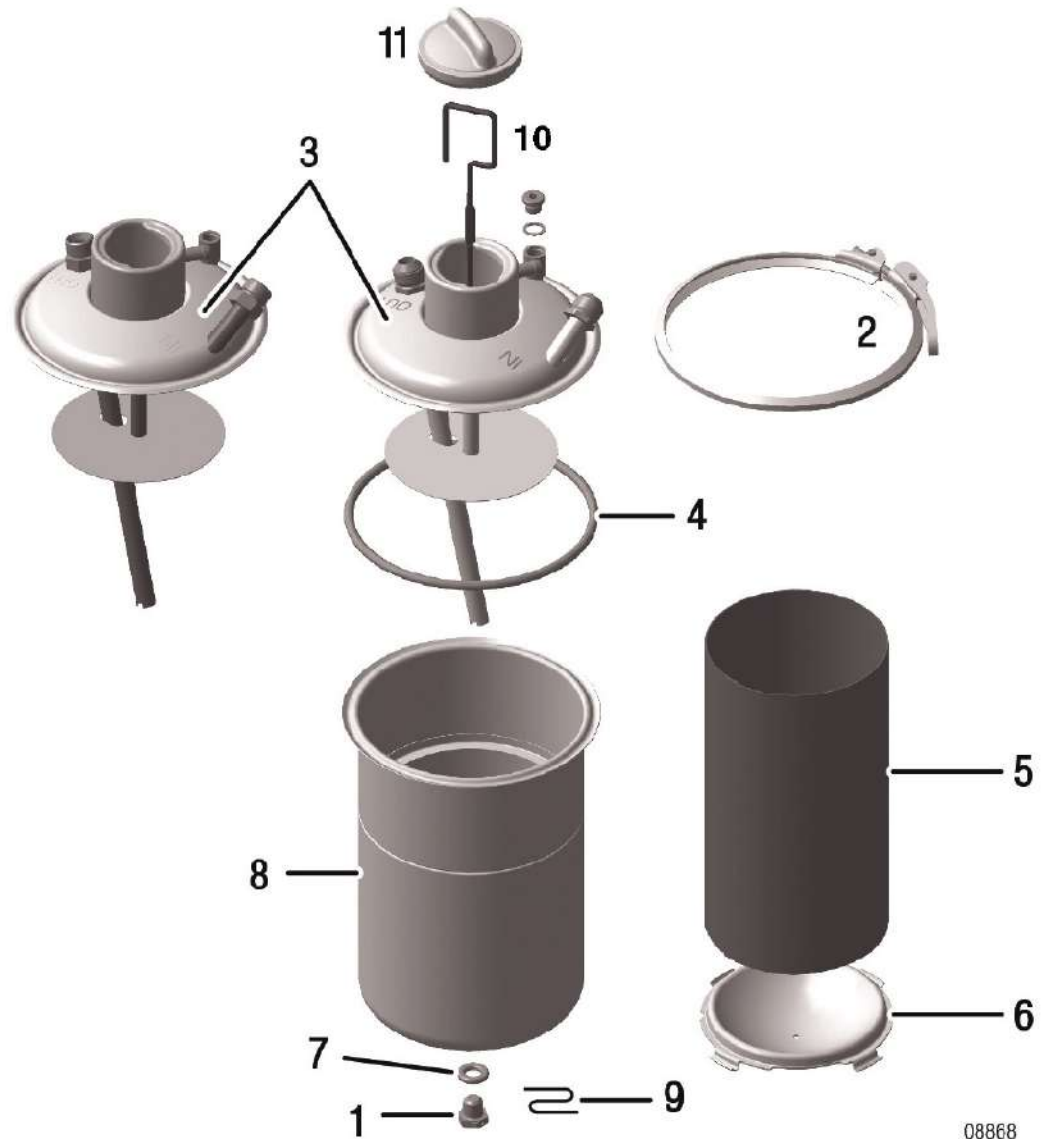

08868

Figure 7.32: Oil tank

- | | | | |
|----|---------------------------------|----|---------------|
| 1 | Hex. screw M12x12 | 2 | Profile clamp |
| 3 | Oil tank cover assy. Metric/ AN | 4 | O-ring |
| 5 | Baffle insert (screen) | 6 | Partition |
| 7 | Gasket ring 12x18 | 8 | Oil tank |
| 9 | Safety wire | 10 | Oil dipstick |
| 11 | Oil tank cover | | |

BRP-Rotax
MAINTENANCE MANUAL LINE

PURGING THE OIL SYSTEM

General note

NOTICE

Purging of the oil system is extremely important for operation and service life of the engine and therefore the procedure must be followed meticulously.

Purging the oil system

Purging the oil system is necessary:

- with initial installation of new engine
- after reinstallation (e.g. after overhaul)
- after maintenance work during which the lubrication system was opened and voided (e.g. removal of the oil tank or oil cooler, replacement of oil lines).

FLUSHING THE OIL CIRCUIT

General note

⚠ WARNING

Risk of electric shock!

Ignition "OFF" and system grounded! Disconnect negative terminal of battery.

Oil tank

Clean the oil tank.

Oil lines

Dismantle and flush oil lines as per instructions of the aircraft manufacturer.

Temporary oil lines

Temporary oil lines (only for flushing) must be fitted so that the oil radiator is not connected. The return line is routed into a separate, clean receptacle and not back to the oil tank.

NOTE

This is done to prevent metal chips and other debris from entering the radiator or oil tank.

Filling

Fill the oil tank with approx. 3 l (0.8 gal (US)) of engine oil.

Procedure

The following steps have to be carried out after refilling:

BRP-Rotax
MAINTENANCE MANUAL LINE

NOTICE

The oil level in the tank must not drop below the end of suction pipe, otherwise air will be sucked in again.

Step	Procedure
1	Turn engine by hand in direction of engine rotation to return the oil from the oil from the oil tank into the engine and into the collection container. The procedure is complete when no more contamination can be discovered.
2	Control the oil captured during the rinsing process. The rinsing process is complete when no more contamination can be discovered.
3	Re-install cleaned oil lines and oil cooler according to the manufacturers instruction.
4	Install new oil filter and refill with oil.
5	Purge oil system.

Reconnect negative terminal of aircraft battery.
See [Chapter 12-20-00 section Purging of the oil system](#).

Equipment

NOTICE

Equipment is to be inspected in accordance with the Maintenance Manual of the aircraft manufacturer.

INSPECTING THE MAGNETIC PLUG

General note

NOTE

The magnetic plug is located on the crankcase between cylinder 2 and gearbox.

This inspection is important because it allows conclusions to be drawn on the internal condition of the gearbox and engine and reveals information about possible damage.

Procedure

Remove the magnetic plug and inspect it for accumulation of chips.

Steel chips in low numbers

Steel chips in low numbers as depicted in [Fig. Overview](#) can be tolerated if the accumulation is below 3 mm (0.125 in).

Steel chips in larger numbers

If there are larger accumulations of metal chips on the magnetic plug, the engine must be repaired or overhauled in accordance with the BRP-Rotax instructions for continued airworthiness.

Unclear findings

In the case of unclear findings:

Step	Procedure
1	Rinse magnet in solvent and check again (the contamination may be moly from engine assy.)
2	Flush the oil circuit.
3	Fit a new oil filter.
4	Install the magnetic plug. See Chapter 12-20-00 section Installation of the magnetic plug.
5	Engine test run. See Chapter 12-20-00 section Test run of engine.
6	Inspect the magnetic plug once more.

Contamination

NOTICE

**If the oil circuit is contaminated, replace the oil cooler and flush the oil circuit.
Proper judgement requires years of experience in repair of piston engines.**

Trace the cause and remedy.

BRP-Rotax
MAINTENANCE MANUAL LINE

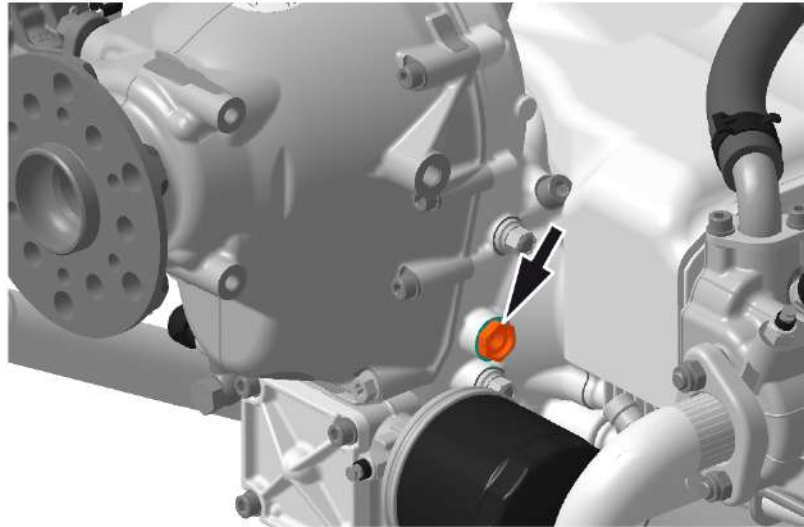

Figure 7.33: Magnetic plug

INSTALLATION OF THE MAGNETIC PLUG

Install

The following steps are necessary:

Step	Procedure
1	Clean the magnetic plug.
2	Install the magnetic plug. Tightening torque 25 Nm (18 ft lb.)
3	Secure with safety wire.

Inspect all systems for correct function. Detailed inspection of affected engine components.

ELECTRIC SYSTEM

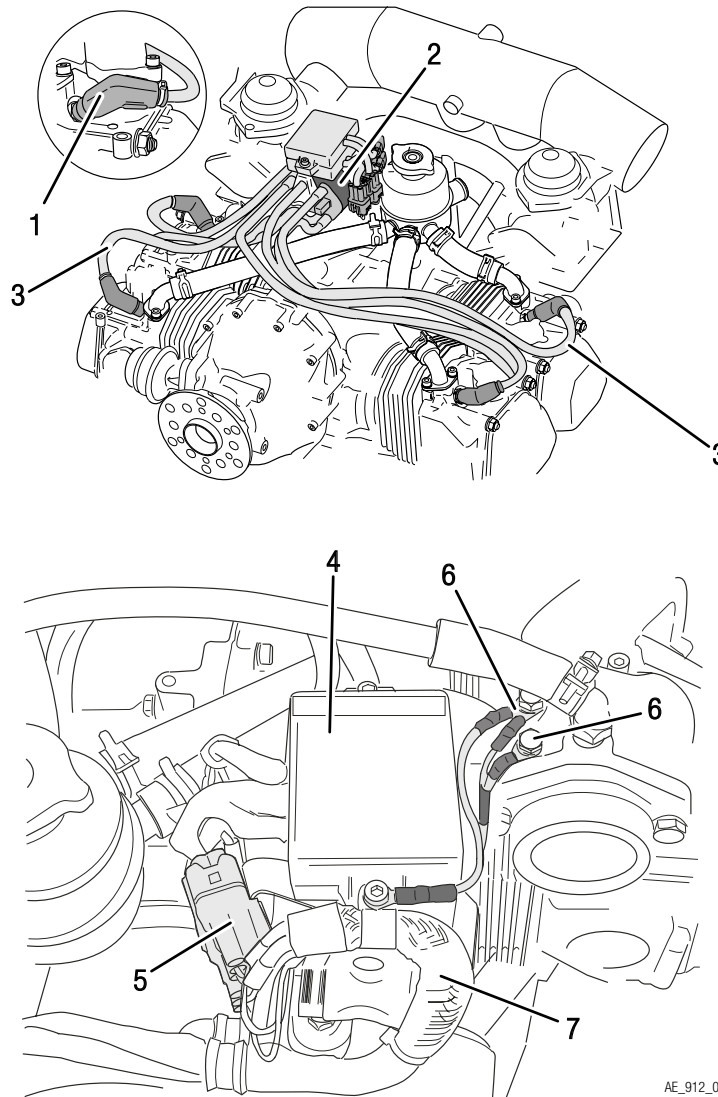

Figure 7.34: Overview

- | | |
|-------------------------|---------------------|
| 1 Spark plug connectors | 2 Double ignition |
| 3 Ignition cable | 4 Electronic module |
| 5 Plug connectors | 6 Grounding cable |
| 7 Protection hose | |

BRP-Rotax
MAINTENANCE MANUAL LINE

CHECK OF WIRING

General note

⚠ WARNING
Risk of electric shock! Ignition "OFF" and system grounded! Disconnect negative terminal of battery.

⚠ WARNING
Risk of burns and scalds. Hot engine parts. Always allow engine to cool down to ambient temperature before starting work.

Procedure

The following steps have to be carried out:

Step	Procedure
1	Inspect all cable connectors and their connections for tight fit, good contact, corrosion or damage and replace as necessary.
2	Inspect all ground connections for corrosion and damage, replace if necessary.
3	Inspect plug connections between pick-up cable, electronic module, charging and shorting cables for corrosion or damage and replace as required.
4	Inspect plug connections between electronic module and ignition coils for corrosion or damage and replace if necessary.
5	Verify plug connections on internal generator cables with rectifier-regulator and connections of all cables on rectifier-regulator for good contact, tight fit, corrosion, discoloration or damage and replace if necessary.
6	Inspect grounding cables for tight fit, corrosion or damage and replace if necessary.
7	Verify shielding of cable assemblies for corrosion or damage, good ground contact and tight fit, inspect the attachment of the shielding and replace if necessary.
8	Inspect all 8 ignition cables to spark plug connector for corrosion or damage and tight fit and replace if necessary.

BRP-Rotax
MAINTENANCE MANUAL LINE

REPLACEMENT OF SPARK PLUGS

General note

NOTICE
Use of incorrect spark plugs can result in ignition problems and pre-ignition and consequent engine damage.

In numerous tests the best possible heat range has been determined to make sure that the spark plug will burn off deposits but will not overheat.

Renewal intervals **NOTE**

Operation with leaded fuels (e.g. AVGAS 100LL) can result in increased wear of the spark plugs. Reduce renewal intervals accordingly.

Spark plugs



See Illustrated Parts Catalog (IPC) for the engine type .

REMOVE THE SPARK PLUGS

Remove Remove the spark plugs and store them according to cylinder and position.

INSPECTION OF SPARK PLUGS

Visual check Inspect all spark plugs for mechanical damage.

Electrode gap **NOTE**

Inspect the electrode gap also on new spark plugs before installation.

Electrode gap	
New	Wear limit
0.8 - 0.9 mm (0.031 - 0.035 in)	1.1 mm (0.043 in)

NOTICE
No adjustment permissible!

Spark plug face Spark plug face reveals the following about the operating condition of the engine:

Spark plug face	Information
light tan- colored	plug and calibration of the engine are correct
velvet black	Possibly indicates one or more of the following: <ul style="list-style-type: none">• mixture too rich• insufficient air intake (clogged air filter)

BRP-Rotax
MAINTENANCE MANUAL LINE

Spark plug face	Information
	<ul style="list-style-type: none">• engine operating temperature too low
oily, glossy coating	Possibly indicates one or more of the following: <ul style="list-style-type: none">• damaged valve stem seal• misfiring• too much oil in combustion chamber• worn cylinder and piston rings
white with formation of melt beads	Possibly indicates one or more of the following: <ul style="list-style-type: none">• mixture too lean• leaking valves

BRP-Rotax
MAINTENANCE MANUAL LINE

INSTALLATION OF SPARK PLUG

I Overview

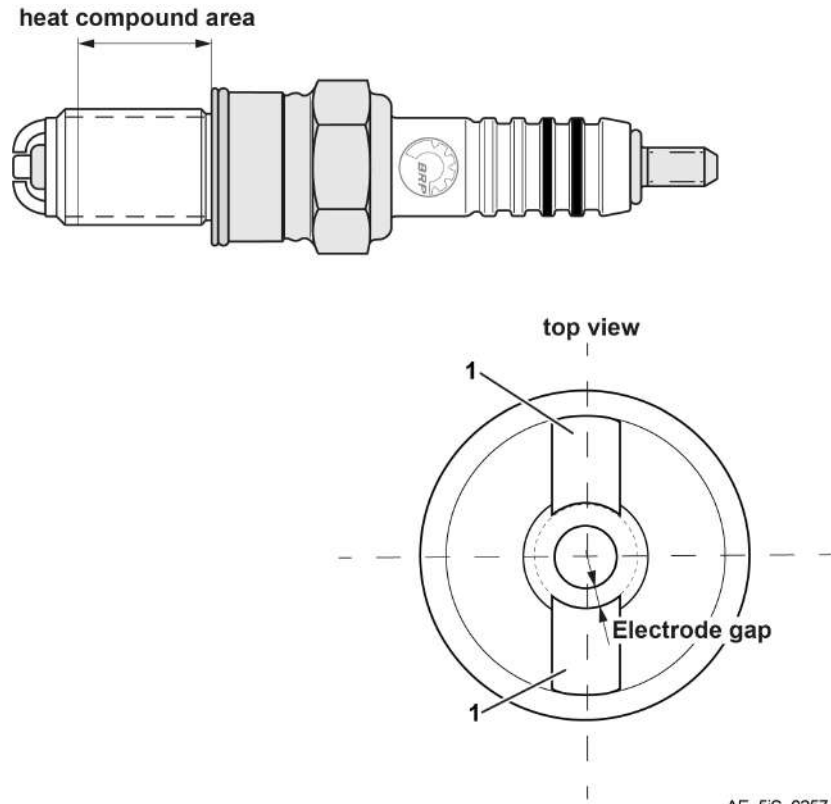

AE_5iS_0257_b

Figure 7.35: Spark plugs

1 Ground electrode

Cleaning

⚠ WARNING	
Eyes and skin irritation!	
Rinse off with water in the case of contact with eyes or skin. May be harmful if swallowed.	

Step	Procedure
1	Before every installation, the spark plug thread and the spark plug seat at the cylinder head should be cleaned (e.g. to remove residue of silicone heat compound).

BRP-Rotax
MAINTENANCE MANUAL LINE

Installation

NOTICE	
Always replace both spark plugs of a cylinder and do not interchange spark plugs between cylinders.	

NOTICE	
Silicone heat compound at the ground electrode or the head area can lead to ignition problems. Apply heat compound sparingly and do not apply to the first three threads.	

Step	Procedure
2	Apply small amount of silicone heat compound to spark plug thread and tighten spark plug to 16 Nm (142 in. lb) on the cold engine.

BRP-Rotax
MAINTENANCE MANUAL LINE

TURBOCHARGER

General note

NOTICE

Damage to the bowden cable is not permissible. If only 1 flexible wire of the bowden cable is abraded, the cable must be replaced.

See Chapter 78-00-00 of the Maintenance Manual Heavy (MMH).

Checking the wastegate flap

The following checks must be carried out:

Step	Procedure
1	Check the Bowden cable of the wastegate actuation for mechanical damage or wear.
2	Check the Bowden cable suspension and spring.
3	<p>Check the adjustment of the wastegate flap.</p> <p>NOTE</p> <p><i>When the engine has been shut down, the servo motor always runs to closed position. This also applies when the TCU is switched on. The servo motor moves approx. 1/2 revolution and then remains in closed position.</i></p> <p>In this position, the wastegate flap must be completely closed. If necessary, re-adjust using the adjusting screw (2). See Chapter 78-00-00 of the Maintenance Manual Heavy (MMH).</p>
4	<p>Check the wastegate lever for free movement.</p> <p>NOTE</p> <p><i>If it does not move freely, clean lubrication hole and lubricate the axle of the wastegate with LOCTITE Anti-Seize 8151, ROTAX® part no. 297434.</i></p>

BRP-Rotax
MAINTENANCE MANUAL LINE

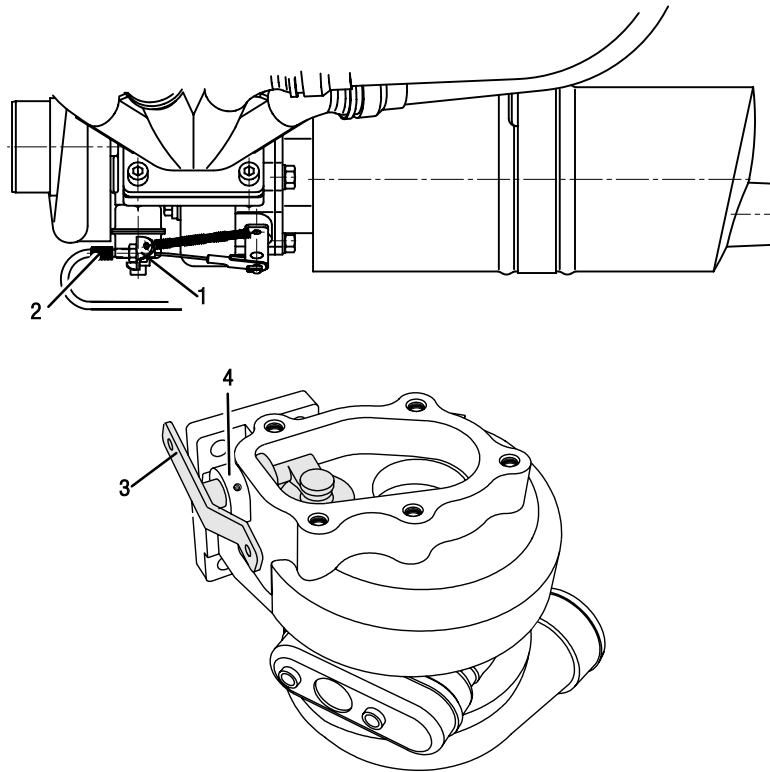

Figure 7.36: Checking the wastegate flap

1 *Wastegate actuation*

2 *Adjusting screw*

3 *Wastegate lever*

4 *Lubrication hole*

PROPELLER GEARBOX

CHECKING THE PROPELLER GEARBOX

General note



See Heavy Maintenance Manual Heavy (MMH) for the engine type .

The gearbox must be inspected, repaired or overhauled in accordance with the BRP-Rotax instructions for continued airworthiness.

Detailed inspection of the affected gearbox components in accordance Chapter 72-00-00 in the Maintenance Manual Heavy (MMH).

NDT Crack testing of the propeller shaft is not normally planned, but can be carried out if cracks are suspected.

For removing the gearbox, please follow the instruction in Chapter 05-50-00 "REMOVAL OF THE PROPELLER GEARBOX", also for installation of the gearbox in Chapter 05-50-00 "INSTALLATION OF PROPELLER GEARBOX". The checks are not equal to the propellerstrike inspection, but how to disassemble and assemble the gearbox is the same procedure.

NOTE

The drive gear is considered part of the gearbox. Therefore it must be removed from the crankshaft and be included when sending the gearbox for repairs or overhaul.

CHECKING THE FRICTION TORQUE IN FREE ROTATION

General note

⚠ WARNING

Risk of electric shock!
Ignition "OFF" and system grounded!

Test procedure

The following steps are necessary for the testing procedure

Step	Procedure
1	Fit the crankshaft locking pin. See Chapter 12-20-00 section: Locking the crankshaft.
2	With the crankshaft locked, the propeller can be turned by hand 15 or 30 degrees depending on the profile of the dog gears installed. This is the maximum amount of movement allowed by the dog gears in the torsional shock absorption unit.
3	Turn the propeller by hand back and forth between ramps, taking into consideration the friction torque. No odd noises or irregular resistance must be noticeable during this moment.

BRP-Rotax
MAINTENANCE MANUAL LINE

Step	Procedure
4	Attach a calibrated spring scale to the propeller in distance (L) from the center of the propeller. Measure the force required to pull the propeller through the 15 or 30 degree range of free rotation.
5	Calculate friction torque (Nm) by multiplying the force (N) obtained on the spring scale by the distance the scale is attached from the center of the propeller (L). The friction torque must be between 30 Nm and max. 70 Nm (22 to 51.6 ft. lb). See calculation example.

NOTICE

If the above mentioned friction torque value is not achieved, inspect, repair or overhaul the gearbox in accordance with the instructions for continued airworthiness.

Step	Procedure
6	Remove crankshaft locking pin. See Chapter 12–20–00 section: Locking the crankshaft.

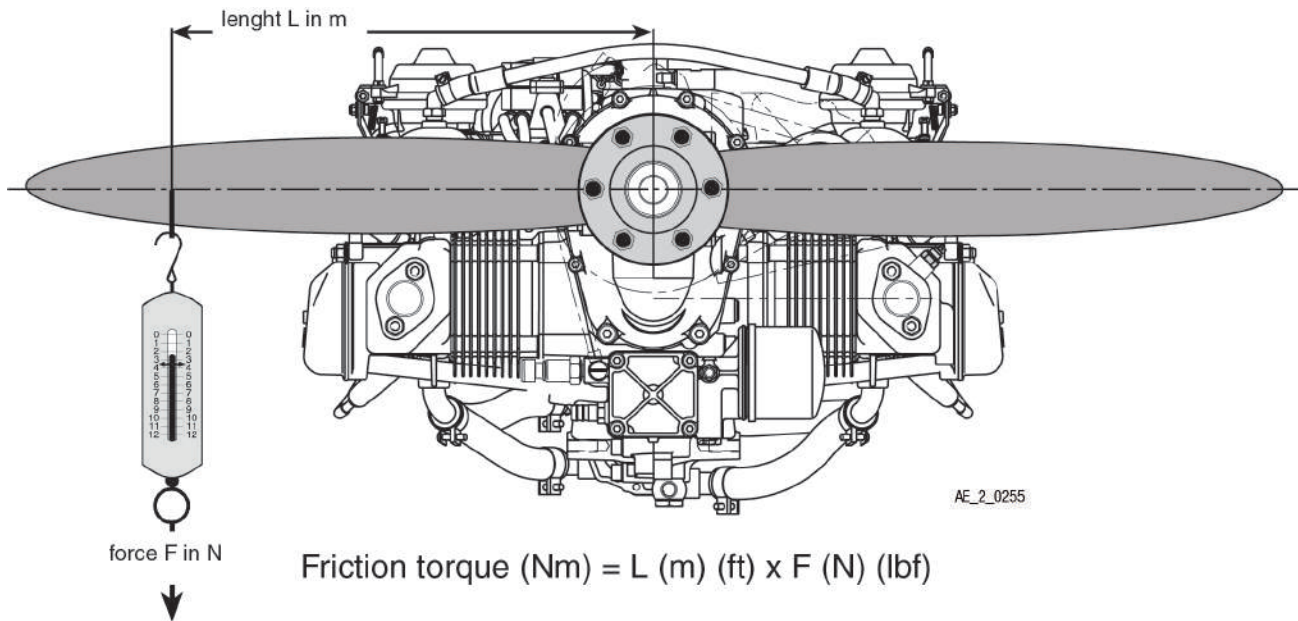

Figure 7.37: Checking the friction torque

BRP-Rotax
MAINTENANCE MANUAL LINE

Index

A

Abbreviations.....	3
Acceptable methods, techniques and practice	12
Accessories.....	27
Air intake system.....	19
Airworthiness Limitations	1
Annual inspection.....	6
Authorized personnel	4

C

Carburetor synchronization	29
Check List/Maintenance Schedule.....	7
Check of wiring	60
Check the weight of floats	39
Check valves	44
Checking of the Cooling system / radiator cap	40
Checking of the float chamber	38
Checking of the overload clutch.....	18
Checking the carburetor actuation	42
Checking the cooling system.....	23
Checking the engine suspension	5
Checking the friction torque in free rotation.....	67
Checking the fuel lines.....	43
Checking the propeller gearbox.....	67
Cleaning the oil tank	53
Cleaning, Air filter.....	19
Compression check for fault tracing	11
Consumable Materials.....	8
Conversion table.....	9
Coolant check/replenish	4
Cooling system	4, 22
Corrosion	5

D

Definition of terms	2
Differential pressure check.....	8

E

Electric system.....	59
Engine check after propeller strike incidents	3
Engine cleaning	3
Engine submerging in water.....	23
Examination after engine failure	21

Exceeding of max. admissible engine RPM	25
Exceeding of max. cooling system temperature	27
Exceeding the max. permissible oil temperature	32
Expansion tank	26
Extreme climatic conditions.....	25

F

Failure of the voltage supply for the turbo control unit (TCU)	53
Fluid capacities	3
Flushing the cooling system	25
Flushing the oil circuit	55
Fuel pump	44
Fuel rail	44
Fuel system	28

G

General	2
General overhaul, TBO.....	3

I

Idle speed adjustment	41
Idle speed check	35
Influence by fire.....	25
Inspecting the magnetic plug.....	57
Inspection of spark plugs	61
Inspection of the fuel filter in the airframe	44
Inspection of the oil filter components	49
Install oil filter.....	51
Installation of propeller gearbox.....	12
Installation of spark plug	63
Installation of the magnetic plug	58
Instruction	13

L

Leak tests.....	43
Leakage check.....	6
Life cycle	3
Lightning strike.....	53
List of effective pages	1
Locking/Loosening of the crankshaft.....	13
Lubrication.....	45

BRP-Rotax

MAINTENANCE MANUAL LINE

Lubrication system 6

M

Maintenance Concept..... 14
 Maintenance Schedule 9
 Maintenance schedule procedures 6
 Mechanical synchronization 30

N

Non compliance — coolant specification 31
 Non compliance — fuel quality 39

O

Oil change 47
 Oil filter removing 48
 Oil level check/Replenish 6
 Oil pressure below minimum value 33
 Oil specification not respected 36
 Operating hours 2
 Operating range check 36
 Orange caution lamp of the boost pressure control is flashing 52
 Overflow bottle 27

P

Periodic rise and fall in boost pressure and speed (vibration of turbo control unit) 48
 Pneumatic synchronization 31
 Procedure notes 5
 Propeller gearbox 67
 Propeller gearbox without integrated overload clutch 17
 Propeller Strike Inspection 7
 Purging the oil system 3, 55

R

Radiator cap 26
 Red boost lamp of the boost pressure control is flashing 50
 Red boost lamp of the boost pressure control lights up continuously 49
 Removal of the drive gear 6
 Removal of the propeller gearbox 3

Remove the spark plugs 61
 Replacement of spark plugs 61
 Replacing the coolant 23
 Replacing the dry air filter 21
 Replenishing operating fluids 1
 Reporting 54

S

Safety 10
 Safety information 11
 Scheduled maintenance 2
 Scheduled maintenance checks 1–2
 Servicing points on the engine 2
 Smooth performance of the engine 46
 Spark plug not in accordance with specification 38
 Sudden drop in boost pressure and speed 47
 Sudden increase in boost pressure and speed 48

T

Table of amendments 1
 Technical documentation 15
 Terminology 2
 Terms 3
 Test run of engine 15
 Time limit 2
 Time Limit 4
 Time limit for fuel pump 6
 Time limit for the coolant 6
 Time limit, parts 6
 Time limits 1
 Troubleshooting 7
 Turbocharger 65

U

Unscheduled maintenance checks 3, 1
 Use for intended purpose 17

V

Visual inspection 5, 4

W

Wiring color codes 8

ROTAX®

Engine serial no.

Type of aircraft

Aircraft registration no.

Rotax® authorized distributor

FLYROTAX.COM

® and TM are trademarks of BRP-Rotax GmbH & Co KG.

© 2024 BRP-Rotax GmbH & Co KG. All rights reserved.

