

ROTAX®

915 iS

ROTAX

**Cyl 11
Cyl 1T**

INSTALLATION MANUAL

FOR ROTAX ENGINE TYPE 915 i A / C24 SERIES

REF NO.: IM-915 i A / C24 | PART NO.: 898871



WARNING

Before starting with engine installation, please read the Installation Manual completely as it contains important safety relevant information.

This Installation Manual for the ROTAX[®] aircraft engines should only be used as a general installation guide for the installation of ROTAX[®] engines into airframes. It should not be used as instruction for the installation of a ROTAX[®] aircraft engine in a specific type of airframe or airplane. BRP-Rotax GmbH & Co KG does not assume any warranty or liability in this context.

In no event shall the Installation Manual be used without following the specific instructions and/or requirements of the manufacture of an airframe or airplane ("Manufacturer"). For verification and/or for release of the engine installation, the respective Manufacturer must be contacted. Any modifications or adaptations to the airframe or airplane shall be carried out and/or be verified and released by the Manufacturer only.

Improper use of the Installation Manual and/or non compliance with the installation requirements of the Manufacturers can cause personal injury or property damage. BRP-Rotax GmbH & Co. KG disclaims any liability for any and all damage and/or injuries (including death) resulting from the improper use of Installation Manual and non compliance with the installation requirements of the Manufacturer.

These technical data and the information embodied therein are the property of BRP-Rotax GmbH & CO KG, Austria, acc, BGBl 1984 no. 448, and shall not, without prior written permission of BRP-Rotax GmbH & Co KG, be disclosed in whole or in part to third parties. This legend shall be included on any reproduction of these data, in whole or in part. The Manual must remain with the engine/aircraft in case of sale.

ROTAX[®] is a trademark of BRP-Rotax GmbH & Co KG. In the following document the short form of BRP-Rotax GmbH & Co KG = BRP-Rotax is used.

Other product names in this documentation are used purely for ease of identification and may be trademarks of the respective company or owner.

Copyright 2024 © - all rights reserved.

Translation into other languages might be performed in the course of language localization but does not lie within ROTAX[®] scope of responsibility. In any case the original text in English language and themetric units are authoritative.

BRP-Rotax
INSTALLATION MANUAL

Table of Content

Chapter	INTRO – GENERAL NOTE
Chapter	LEP – LIST OF EFFECTIVE PAGES
Chapter	TOA – TABLE OF AMENDMENTS
Chapter	00-00-00 – GENERAL NOTE
Chapter	10-10-00 – STORAGE AND INSTALLATION
Chapter	24-00-00 – ELECTRICAL POWER
Chapter	61-00-00 – PROPELLER DRIVE
Chapter	72-00-00 – ENGINE
Chapter	72-60-00 – AIR INTAKE SYSTEM
Chapter	73-00-00 – ENGINE – FUEL AND CONTROL
Chapter	75-00-00 – COOLING SYSTEM
Chapter	76-00-00 – ENGINE CONTROLS
Chapter	77-00-00 – ENGINE INDICATING
Chapter	78-00-00 – EXHAUST SYSTEM
Chapter	79-00-00 – LUBRICATION SYSTEM
Chapter	80-00-00 – STARTING
Chapter	92-00-00 – WIRING DIAGRAMS
Chapter	APPENDIX – OPERATIONAL AND INSTALLATION CONSIDERATIONS

BRP-Rotax
INSTALLATION MANUAL

INTENTIONALLY LEFT
BLANK

BRP-Rotax INSTALLATION MANUAL

Chapter: INTRO GENERAL NOTE

Foreword

Before carrying out engine installation related work on the engine, read this Installation Manual carefully. The manual will provide you with basic information on correct engine installation for safe engine operation.

If any passages of the manual are not clearly understood or if you have any questions, please contact a ROTAX® authorized distributor or their independent Service Center for ROTAX® aircraft engines.

BRP-Rotax GmbH & Co KG (hereinafter "BRP-Rotax") wishes you much pleasure and satisfaction flying your aircraft powered by this ROTAX® aircraft engine.

The structure of the manual follows, whenever possible, the structure of the ATA (Air Transport Association) standards. The aim is the compatibility with the aircraft manufacturers documentation, which means they still must adapt or incorporate the documentation to their standard.

BRP-Rotax
INSTALLATION MANUAL

INTENTIONALLY LEFT
BLANK

BRP-Rotax
INSTALLATION MANUAL

Chapter: LEP
LIST OF EFFECTIVE PAGES

Each new revision to the Installation Manual will have a new List of Effective Pages.

Chapter	Page	Date	Chapter	Page	Date
	Title page			13	February 01 2024
INTRO	1	February 01 2024		14	February 01 2024
	2	February 01 2024		15	February 01 2024
LEP	1	February 01 2024		16	February 01 2024
	2	February 01 2024		17	February 01 2024
	3	February 01 2024		18	February 01 2024
	4	February 01 2024		19	February 01 2024
	5	February 01 2024		20	February 01 2024
TOA	1	February 01 2024	10-10-00	1	February 01 2024
	2	February 01 2024		2	February 01 2024
	3	February 01 2024		3	February 01 2024
	4	February 01 2024		4	February 01 2024
	5	February 01 2024		5	February 01 2024
	6	February 01 2024		6	February 01 2024
00-00-00	1	February 01 2024		7	February 01 2024
	2	February 01 2024		8	February 01 2024
	3	February 01 2024	24-00-00	1	February 01 2024
	4	February 01 2024		2	February 01 2024
	5	February 01 2024		3	February 01 2024
	6	February 01 2024		4	February 01 2024
	7	February 01 2024		5	February 01 2024
	8	February 01 2024		6	February 01 2024
	9	February 01 2024		7	February 01 2024
	10	February 01 2024		8	February 01 2024
	11	February 01 2024		9	February 01 2024
	12	February 01 2024		10	February 01 2024

BRP-Rotax
INSTALLATION MANUAL

Chapter	Page	Date
	11	February 01 2024
	12	February 01 2024
	13	February 01 2024
	14	February 01 2024
	15	February 01 2024
	16	February 01 2024
	17	February 01 2024
	18	February 01 2024
	19	February 01 2024
	20	February 01 2024
	21	February 01 2024
	22	February 01 2024
	23	February 01 2024
	24	February 01 2024
	25	February 01 2024
	26	February 01 2024
	27	February 01 2024
	28	February 01 2024
61-00-00	1	February 01 2024
	2	February 01 2024
	3	February 01 2024
	4	February 01 2024
	5	February 01 2024
	6	February 01 2024
	7	February 01 2024
	8	February 01 2024
	9	February 01 2024
	10	February 01 2024
72-00-00	1	February 01 2024
	2	February 01 2024

Chapter	Page	Date
	3	February 01 2024
	4	February 01 2024
	5	February 01 2024
	6	February 01 2024
	7	February 01 2024
	8	February 01 2024
	9	February 01 2024
	10	February 01 2024
	11	February 01 2024
	12	February 01 2024
	13	February 01 2024
	14	February 01 2024
72-60-00	1	February 01 2024
	2	February 01 2024
	3	February 01 2024
	4	February 01 2024
	5	February 01 2024
	6	February 01 2024
	7	February 01 2024
	8	February 01 2024
	9	February 01 2024
	10	February 01 2024
	11	February 01 2024
	12	February 01 2024
73-00-00	1	February 01 2024
	2	February 01 2024
	3	February 01 2024
	4	February 01 2024
	5	February 01 2024
	6	February 01 2024

BRP-Rotax
INSTALLATION MANUAL

Chapter	Page	Date
	7	February 01 2024
	8	February 01 2024
	9	February 01 2024
	10	February 01 2024
	11	February 01 2024
	12	February 01 2024
	13	February 01 2024
	14	February 01 2024
75-00-00	1	February 01 2024
	2	February 01 2024
	3	February 01 2024
	4	February 01 2024
	5	February 01 2024
	6	February 01 2024
	7	February 01 2024
	8	February 01 2024
	9	February 01 2024
	10	February 01 2024
	11	February 01 2024
	12	February 01 2024
	13	February 01 2024
	14	February 01 2024
76-00-00	1	February 01 2024
	2	February 01 2024
	3	February 01 2024
	4	February 01 2024
	5	February 01 2024
	6	February 01 2024
	7	February 01 2024
	8	February 01 2024

Chapter	Page	Date
	9	February 01 2024
	10	February 01 2024
	11	February 01 2024
	12	February 01 2024
	13	February 01 2024
	14	February 01 2024
	15	February 01 2024
	16	February 01 2024
	17	February 01 2024
	18	February 01 2024
	19	February 01 2024
	20	February 01 2024
77-00-00	1	February 01 2024
	2	February 01 2024
	3	February 01 2024
	4	February 01 2024
	5	February 01 2024
	6	February 01 2024
	7	February 01 2024
	8	February 01 2024
	9	February 01 2024
	10	February 01 2024
	11	February 01 2024
	12	February 01 2024
	13	February 01 2024
	14	February 01 2024
	15	February 01 2024
	16	February 01 2024
	17	February 01 2024
	18	February 01 2024

BRP-Rotax
INSTALLATION MANUAL

Chapter	Page	Date
78-00-00	19	February 01 2024
	20	February 01 2024
	1	February 01 2024
	2	February 01 2024
	3	February 01 2024
	4	February 01 2024
79-00-00	5	February 01 2024
	6	February 01 2024
	1	February 01 2024
	2	February 01 2024
	3	February 01 2024
	4	February 01 2024
	5	February 01 2024
	6	February 01 2024
	7	February 01 2024
	8	February 01 2024
	9	February 01 2024
	10	February 01 2024
	11	February 01 2024
	12	February 01 2024
80-00-00	13	February 01 2024
	14	February 01 2024
	15	February 01 2024
	16	February 01 2024
	17	February 01 2024
	18	February 01 2024
	19	February 01 2024
	20	February 01 2024
80-00-00	1	February 01 2024
	2	February 01 2024

Chapter	Page	Date	
	3	February 01 2024	
	4	February 01 2024	
	5	February 01 2024	
	6	February 01 2024	
	7	February 01 2024	
	8	February 01 2024	
	9	February 01 2024	
	10	February 01 2024	
	11	February 01 2024	
	12	February 01 2024	
	92-00-00	1	February 01 2024
		2	February 01 2024
APPENDIX	1	February 01 2024	
	2	February 01 2024	
	3	February 01 2024	
	4	February 01 2024	
	5	February 01 2024	
	6	February 01 2024	
	7	February 01 2024	
	8	February 01 2024	
	9	February 01 2024	
	10	February 01 2024	
	11	February 01 2024	
	12	February 01 2024	
	13	February 01 2024	
	14	February 01 2024	
	15	February 01 2024	
	16	February 01 2024	
17	February 01 2024		
18	February 01 2024		

BRP-Rotax
INSTALLATION MANUAL

Chapter	Page	Date
	Index	

Chapter	Page	Date
	Rear page	

BRP-Rotax
INSTALLATION MANUAL

INTENTIONALLY LEFT
BLANK

BRP-Rotax
INSTALLATION MANUAL

Chapter: TOA
TABLE OF AMENDMENTS

Approval*
The technical content of this document is approved. It is issued under the authority of the DOA ref. EASA. 21J.048.

Edition 0/Rev. 0	December 01 2017	
Revision 1	June 01 2019	
Revision 2	Feb. 01 2020	
Revision 3	Oct. 01 2020	
Revision 4	July 01 2021	Obsolete with Revision 5, which is a complete re-revision
Revision 5	Feb. 01 2024	

Rev. no.	Chapter	Page	Date of change	Remark for approval	Date of approval from authorities	Date of inclusion	Signature
0	INTRO	all	December 01 2017	DOA*			
0	LEP	all	December 01 2017	DOA*			
0	TOA	all	December 01 2017	DOA*			
0	00-00-00	all	December 01 2017	DOA*			
0	10-10-00	all	December 01 2017	DOA*			
0	24-00-00	all	December 01 2017	DOA*			
0	61-00-00	all	December 01 2017	DOA*			
0	72-00-00	all	December 01 2017	DOA*			
0	72-60-00	all	December 01 2017	DOA*			
0	73-00-00	all	December 01 2017	DOA*			
0	75-00-00	all	December 01 2017	DOA*			
0	76-00-00	all	December 01 2017	DOA*			
0	77-00-00	all	December 01 2017	DOA*			
0	78-00-00	all	December 01 2017	DOA*			
0	79-00-00	all	December 01 2017	DOA*			
0	80-00-00	all	December 01 2017	DOA*			

BRP-Rotax
INSTALLATION MANUAL

Rev. no.	Chapter	Page	Date of change	Remark for approval	Date of approval from authorities	Date of inclusion	Signature
1	LEP	all	June 01 2019	DOA*			
1	TOA	all	June 01 2019	DOA*			
1	00-00-00	3, 4, 5,10,15,17	June 01 2019	DOA*			
1	10-00-00	2,5	June 01 2019	DOA*			
1	24-00-00	2,3,7,8,13	June 01 2019	DOA*			
1	61-00-00	4,5,6,9	June 01 2019	DOA*			
1	72-00-00	2,4 up to 7, 9, 10	June 01 2019	DOA*			
1	72-60-00	3 up to 7	June 01 2019	DOA*			
1	73-00-00	10	June 01 2019	DOA*			
1	75-00-00	3,5,7,10,11	June 01 2019	DOA*			
1	76-00-00	9,12	June 01 2019	DOA*			
1	77-00-00	3,8	June 01 2019	DOA*			
1	78-00-00	3,4	June 01 2019	DOA*			
1	79-00-00	2,3,8,11,15	June 01 2019	DOA*			
1	APPEN-DIX	all	June 01 2019	DOA*			

Rev. no.	Chapter	Page	Date of change	Remark for approval	Date of approval from authorities	Date of inclusion	Signature
2	LEP	all	Feb. 01 2020	DOA*			
2	TOA	all	Feb. 01 2020	DOA*			
2	61-00-00	6	Feb. 01 2020	DOA*			
2	72-60-00	4, 5	Feb. 01 2020	DOA*			
2	73-00-00	8	Feb. 01 2020	DOA*			
2	79-00-00	4, 5	Feb. 01 2020	DOA*			

BRP-Rotax
INSTALLATION MANUAL

Rev. no.	Chapter	Page	Date of change	Remark for approval	Date of approval from authorities	Date of inclusion	Signature
3	LEP	all	Oct. 01 2020	DOA*			
3	TOA	all	Oct. 01 2020	DOA*			
3	24-00-00	12	Oct. 01 2020	DOA*			
3	61-00-00	3	Oct. 01 2020	DOA*			
3	73-00-00	5,8	Oct. 01 2020	DOA*			
3	76-00-00	4	Oct. 01 2020	DOA*			
3	79-00-00	3,4,13	Oct. 01 2020	DOA*			

Rev. no.	Chapter	Page	Date of change	Remark for approval	Date of approval from authorities	Date of inclusion	Signature
4	LEP	all	July 01 2021	DOA*			
4	TOA	all	July 01 2021	DOA*			
4	00-00-00	3,18	July 01 2021	DOA*			
4	10-00-00	4	July 01 2021	DOA*			
4	24-00-00	3,5,12-29	July 01 2021	DOA*			
4	72-00-00	9	July 01 2021	DOA*			
4	72-60-00	3	July 01 2021	DOA*			
4	73-00-00	5,6,7	July 01 2021	DOA*			
4	76-00-00	3,4,10-13,18,19	July 01 2021	DOA*			
4	77-00-00	3,9-11,16-19	July 01 2021	DOA*			
4	79-00-00	3,4	July 01 2021	DOA*			
4	80-00-00	4,5,7	July 01 2021	DOA*			
4	92-00-00	1,2	July 01 2021	DOA*			

BRP-Rotax
INSTALLATION MANUAL

Rev. no.	Chapter	Page	Date of change	Remark for approval	Date of approval from authorities	Date of inclusion	Signature
5	LEP	all	Feb. 01 2024	DOA*			
5	TOA	all	Feb. 01 2024	DOA*			
5	00-00-00	20	Feb. 01 2024	DOA*			
5	24-00-00	5	Feb. 01 2024	DOA*			
5	61-00-00	3,6	Feb. 01 2024	DOA*			
5	72-00-00	11	Feb. 01 2024	DOA*			
5	72-60-00	9	Feb. 01 2024	DOA*			
5	75-00-00	7–11	Feb. 01 2024	DOA*			
5	78-00-00	3	Feb. 01 2024	DOA*			
5	79-00-00	3,5,7	Feb. 01 2024	DOA*			
5	80-00-00	9	Feb. 01 2024	DOA*			

BRP-Rotax INSTALLATION MANUAL

Summary of amendments

Summary of the relevant amendments in this context, but without any claim to completeness.

Rev. no.	Chapter	Page	Date of change	Comment
1	00-00-00	3	June 01 2019	Configuration 2 added
1		10	June 01 2019	Wiring color codes
1	24-00-00	2,13	June 01 2019	New figure
1	61-00-00	5,6	June 01 2019	New figure
1	72-00-00	9, 10	June 01 2019	Change of text
1	72-60-00	3–7	June 01 2019	Change of text, new figures
1	75-00-00	5,7,10	June 01 2019	Change of text
1	76-00-00	9,12	June 01 2019	Change of text, Update of figures
1	77-00-00	8	June 01 2019	Update of figures
1	78-00-00	3,4	June 01 2019	New figures
1	79-00-00	2,3,8,11,15	June 01 2019	Change of text, new figures
1	APPENDIX	all	June 01 2019	Appendix added

Rev. no.	Chapter	Page	Date of change	Comment
2	61-00-00	6	Feb. 01 2020	Change of text
2	72-60-00	4,5	Feb. 01 2020	Change of text, Update of figures
2	73-00-00	8	Feb. 01 2020	Change of text, Update of figures
2	79-00-00	4,5	Feb. 01 2020	Change of text

Rev. no.	Chapter	Page	Date of change	Comment
3	24-00-00	12	Oct. 01 2020	Change of text
3	61-00-00	3	Oct.01.2020	New figures
3	73-00-00	5,8	Oct. 01 2020	Update of figures
3	76-00-00	4	Oct. 01 2020	Change of text
3	79-00-00	3,4,13	Oct. 01 2020	Change of text

Rev. no.	Chapter	Page	Date of change	Comment
4	00-00-00	3,19	July 01 2021	New engine type, Change of text
4	24-00-00	3,5,12–19	July 01 2021	New text
4	72-00-00	9	July 01 2021	New figures with torque
4	73-00-00	5,7	July 01 2021	New figures, New text
4	76-00-00	3,10-13,18	July 01 2021	New figures, New text
4	77-00-00	3,9-11,16-18	July 01 2021	Change of text, Update of figure
4	79-00-00	3,4	July 01 2021	New text, New figure
4	80-00-00	4,5,7	July 01 2021	New text
4	92-00-00	1,2	July 01 2021	New chapter

BRP-Rotax
INSTALLATION MANUAL

Rev. no.	Chapter	Page	Date of change	Comment
5	00-00-00	20	Feb. 01 2024	Change of text
5	24-00-00	5	Feb. 01 2024	New figure
5	61-00-00	3,6	Feb. 01 2024	New text, New figures
5	72-00-00	11	Feb. 01 2024	New text
5	72-60-00	9	Feb. 01 2024	New figures
5	75-00-00	7-11	Feb. 01 2024	New text, New figure
5	78-00-00	3	Feb. 01 2024	Change of text, Update of figure, New text
5	79-00-00	3,5,7	Feb. 01 2024	Change of text, Update of figure, New text
5	80-00-00	9	Feb. 01 2024	New section

BRP-Rotax
INSTALLATION MANUAL

Chapter: 00-00-00
GENERAL NOTE

TOPICS IN THIS CHAPTER

General	2
Type description	3
Scope of supply	4
Auxiliary equipment (optional)	5
Abbreviations and terms (depending on respective engine type)	6
Wiring color codes	11
Conversion table	12
Safety notice	13
Safety information	14
Instruction	16
Technical documentation	17
Approval of electric and electronic components (Equipment Qualification according to RTCA/DO-160)	19

BRP-Rotax INSTALLATION MANUAL

GENERAL

Purpose

The purpose of this Manual is to provide aircraft manufacturers with technical requirements (e.g. interface descriptions and limitations) that must be adhered to when installing this type of engine into an aircraft or certifying aircraft powered by this engine type. Furthermore it should allow independent ROTAX® Maintenance Technicians (iRMT) to install this engine into an airframe in compliance with the relevant installation and safety instructions provided by the engine manufacturer.

For detailed information related to aircraft and aircraft/engine installation, maintenance, safety or flight operation, consult the documentation provided by the aircraft manufacturer and/or its dealer.

For additional information on engines, its maintenance or parts, you can also contact your nearest ROTAX® authorized Aircraft Engine Distributor or their independent Service Center.

ROTAX Distributors

For ROTAX® Authorized Distributors for aircraft engines see latest Operators Manual or the official website www.FLYROTAX.com.

Engine serial number

When making inquiries or ordering parts, always indicate the engine serial number. Due to continuous product improvement, engines of the same engine type might require different support and spare parts.

The engine serial number is on top of the crankcase, behind the propeller gearbox.

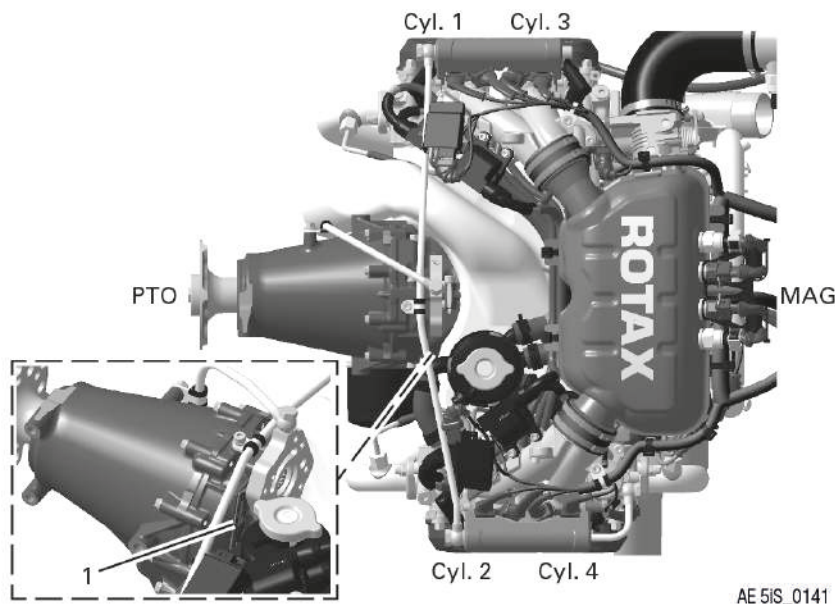

Figure 1.1: Engine serial number

1 Engine serial number

BRP-Rotax INSTALLATION MANUAL

SCOPE OF SUPPLY

Basic

- 4- stroke-, 4 cylinder horizontally opposed-, spark ignition engine, single central cam-shaft push rods —OHV (Over Head Valve)
- Liquid cooled cylinder heads
- Ram air cooled cylinders
- Dry sump forced lubrication
- Fully redundant electronic engine management system (EMS) for controlling fuel injection, ignition, etc.
- Propeller drive via gearbox with integrated torsional vibration absorber and overload clutch
- Oi tank
- Electric starter
- Turbocharger
- Electronic/pneumatic control of boost pressure
- Exhaust system

Optional

- Accessory drive for hydraulic propeller governor (configuration 3 only)
- Cooling air baffle

BRP-Rotax INSTALLATION MANUAL

AUXILIARY EQUIPMENT (OPTIONAL)

Any equipment not included as part of the standard engine version and thus not a fixed component of the engine is not in the volume of supply. Components especially developed and tested for this engine are readily available at BRP-Rotax.

Auxiliary equipment certified

The following auxiliary equipment has been developed and tested for this engine.

- See relevant Illustrated Parts Catalog (IPC)

Auxiliary equipment not certified



The following auxiliary equipment has been developed and tested, but NOT certified for this engine. Certification of auxiliary equipment is the responsibility of the aircraft manufacturer.

- See relevant Illustrated Parts Catalog (IPC)

The representation of components that are not within scope of the delivery is purely symbolic. It does not constitute the specification of the engine version and shall therefore only be seen functionally. The actual interpretation/selection of corresponding regulations is the aircraft manufacturer's responsibility.

BRP-Rotax
INSTALLATION MANUAL

ABBREVIATIONS AND TERMS (DEPENDING ON RESPECTIVE ENGINE TYPE)

Abbreviations	Description
*	Reference to another section
	center of gravity
	The drop symbol indicates use of sealing agents, adhesives or lubricants (only in the Maintenance Manual Heavy)
°C	Degrees Celsius (Centigrade)
°F	Degrees Fahrenheit
rpm	Revolutions per minute
A	Ampere
AAPTS	Ambient Air Pressure Temperature Sensor
AC	alternating current
AD	Airworthiness Directives
Ah	Ampere hour
A/C	Aircraft
AC-DC	EMS Modul voltage converter
AR	as required
assy.	assembly
ASB	Alert Service Bulletin
ACG	Austro Control GmbH
ACL	Anti Collision Light
API	American Petrol Institute
ASTM	American Society for Testing and Materials
ATA	Air Transport Association
AWG	American Wire Gauge
CAN	Controller Area Network
CCS	Camshaft position sensor
Coil 1–4	Ignition coils 1–4
CPS 1+2	Crankshaft Position Sensor 1+2
CSA	Constant Speed Actuator
CTS	Cooling Temperature Sensor

BRP-Rotax INSTALLATION MANUAL

Abbreviations	Description
CW	clockwise
CCW	counter-clockwise
CGSB	Canadian General Standards Board
DCDI	Dual Capacitor Discharge Ignition
DC	direct current
DOA	Design Organisation Approval
DOT	Department of Transport
EASA	European Aviation Safety Agency
IM	Installation Manual
ECU	Engine Control Unit
EGT	Exhaust Gas Temperature
INTRO	Introduction
EMS	Engine Management System
EMS GND	Engine system internal ground reference which is intended to be disconnected from aircraft common ground during flight
EMC	Electromagnetic compatibility
EN	European Standard
ETFE	Ethylene Tetrafluoroethylene
FAA	Federal Aviation Administration
FAR	Federal Aviation Regulations
FOD	Foreign object damage
FL	Flight Level
Fuse box	Power conditioning and distribution for the Engine Management System
hr.	hours
HIC A	Harness Interface Connector A
HIC B	Harness Interface Connector B
IAT	Indicated Air Temperature
ICA	Instructions for Continued Airworthiness
IFR	Instrument Flight Rules
IFSD	In-flight-shutdown
INJ 1–8	Injector 1–8

BRP-Rotax INSTALLATION MANUAL

Abbreviations	Description
IPC	Illustrated Parts Catalog
ips	inch per second
iRMT	independent ROTAX Maintenance Technician
ISA	International Standard Atmosphere
kg	Kilograms
KNOCK	Knock sensor
Lane A	System A of Engine Management System
Lane B	System B of Engine Management System
LOPC	Loss of power control
MAPS 1 & 2	Manifold Air Pressure Sensor 1 & 2
MATS 1 & 2	Manifold Air Temperature Sensor 1 & 2
MCON 1.2	Sealed electrical connector
MON	Motor Octane Number
MAG	Magneto Side
N	Newton
n.a.	not available
NDT	Non Destructive Testing
NEW	Part must be replaced against NEW (mentioned in figures)
Nm	Newtonmeter
NVFR	Night Visual Flight Rules
OAT	Outside Air Temperature
OHM	Overhaul Manual
OHV	Over Head Valve
OM	Operators Manual
OPS	Oil Pressure Sensor
OTS	Oil Temperature Sensor
PCD	Pitch Circle Diameters
PCV	Pressure Control Valve
PMA	Permanent magnet alternator
POA	Production Organization Approval
PS	Power supply

BRP-Rotax INSTALLATION MANUAL

Abbreviations	Description
PTFE	Polytetrafluoroethylene (Teflon)
PTO	Power Take Off
Rev.	Revision
ROTAX®	is a trademark of BRP-Rotax GmbH & Co KG
RON	Research Octane Number
RON 424	ROTAX® Standard 424
s.v.	still valid (only Illustrated Parts Catalog)
S/N	Serial Number
SAE	Society of Automotive Engineers
SEP	Single Engine Piston
SB	Service Bulletin
SI	Service Instruction
SI-PAC	Service Instruction Parts and Accessories
SPST	Single pole single throw
STP	Shielded twisted pair wire
SL	Service Letter
SMD	Surface Mounted Devices
TBO	Time Between Overhaul
TC	Type certificate
part no.	part number
TOA	Table Of Amendments
TOC	Table Of Contents
TPS	Throttle Position Sensor
TSN	Time Since New
TSNP	Time Since New Part
TSO	Time Since Overhaul
V	Volt
VFR	Visual Flight Rules
LEP	List of Effective Pages
MM	Maintenance Manual
MEP	Multi Engine Piston











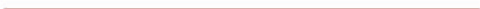



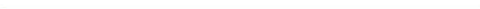

BRP-Rotax
INSTALLATION MANUAL

Abbreviations	Description
X3	Connector on Engine Management System wiring harness which serves as an interface for power supply
XXXX	shows the component serial number

WIRING COLOR CODES

IEC 60757

Color codes (wiring)

black		BK
brown		BN
red		RD
orange		OG
yellow		YE
green		GN
blue		BU
violet		VT
gray		GY
white		WH
pink		PK
turquoise		TQ
Light blue		LBU
Dark blue		DBU
gold		GD
silver		SR
green-yellow		GNYE

10336

Figure 1.2

BRP-Rotax
INSTALLATION MANUAL

CONVERSION TABLE

Units of length:	Units of power:
1 mm = 0.03937 in 1 in = 25.4 mm 1 ft = 12 in = 0.3048 m	1 kW = 1.341 hp 1 hp = 0.7457 kW 1 kW = 1.3596 PS 1 PS = 0.7355 kW
Units of area:	Units of temperature:
1 cm ² = 0.155 sq. in (in ²) 1 sq. in (in ²) = 6.4516 cm ²	K = °C – 273,15 °C = (°F – 32) / 1,8 °F = (°C x 1.8) +32
Units of volume:	Units of velocity:
1 cm ³ = 0.06102 cu in (in ³) 1 cu in (in ³) = 16.3871 cm ³ 1 dm ³ = 1 l 1 dm ³ = 0.21997 gal (UK) 1 gal (UK) = 4.5461 dm ³ 1 dm ³ = 0.26417 gal (US) 1 gal (US) = 3.7854 dm ³	1 m/s = 3.6 km/h 1 ft/min = 0.3048 m/min = 0.00508 m/sec 1 m/s = 196.85 ft/min 1 kt = 1.852 km/h 1 km/h = 0.53996 kn
Units of mass:	spec. fuel consumption:
1 kg = 2.2046 lbs. 1 lb. = 0.45359 kg	1 g/kWh = 0.001644 lb/hph 1 lb/hph = 608.277 g/kWh
Density:	Units of torque:
1 g/cm ³ = 0.016018 lb/ft ³ 1 lb/ft ³ = 62.43 g/cm ³	1 Nm = 0.737 ft lb = 8.848 in lb 1 ft lb = 1.356 Nm 1 in lb = 0.113 Nm
Units of force:	Cable cross-section: Conversion table- Wire Gauge: AWG-mm²
1 N = 0.224809 lbf 1 lbf = 4.4482 N	AWG → mm ² 4 → 21 6 → 13 8 → 8.4 10 → 5.3 12 → 3.3 14 → 2.1 16 → 1.3 18 → 0.8 20 → 0.52
Units of pressure:	
1 Pa = 1 N/m ² 1 bar = 100 000 Pa / 1000 hPa / 100 kPa 1 bar = 14.503 lbf/in ² (psi) 1 in Hg = 33.8638 hPa	

BRP-Rotax INSTALLATION MANUAL

SAFETY NOTICE

Although reading such information does not eliminate any hazards, it promotes understanding, and applying of the information will promote correct use of the engine. Always apply common workshop safety rules.

The information and descriptions of components and systems contained in this Manual are correct at the time of publication. BRP-Rotax maintains a policy of continuous improvement of its products without imposing upon itself any obligation to retrofit products previously manufactured.

Revisions

BRP-Rotax reserves the right to remove, replace or discontinue any design, specification, feature or other at any time, and without incurring obligation.

Measurement

Specifications are given in the SI metric system with the imperial- and US customary measurement system equivalents in parenthesis.

Symbols used

This Manual uses the following symbols to emphasize particular information. This information is important and must be observed.

⚠ WARNING

Identifies an instruction which, if not followed, may cause serious injury or even fatal injury.

⚠ CAUTION

Identifies an instruction which, if not followed, may cause minor or moderate injury.

NOTICE

Identifies an instruction which, if not followed, may severely damage the engine or could void any warranty.

NOTE

Indicates supplementary information which may be needed to fully complete or understand an instruction.

ENVIRONMENTAL NOTE

Environmental notes give you tips on environmental protection.

A revision bar outside the page margin indicates a change to text or graphic.

BRP-Rotax INSTALLATION MANUAL

SAFETY INFORMATION

Use for intended
purpose

⚠ WARNING

Non-compliance can result in serious injuries or death!

The user has to assume all risks possibly arising from utilizing auxiliary equipment.

⚠ WARNING

Non-compliance can result in serious injuries or death!

Never fly the aircraft equipped with this engine at locations, air speeds, altitudes or in other situations which do not allow a successful no-power landing after sudden engine stoppage.

- This engine is not suitable for aerobatics (inverted flight, etc.). Flight attitudes outside the permissible limits are not allowed
- This engine has exclusively been developed and tested for fixed wing, gyrocopter, pusher and tractor applications. In case of any other usage, the OEM is responsible for testing and the correct function of the engine
- It should be clearly understood that the choice, selection and use of this particular engine on any aircraft is at the sole discretion and responsibility of the aircraft manufacturer, assembler or owner/user
- Due to the varying designs, equipment and types of aircraft, BRP-Rotax grants no warranty on the suitability of its engines use on any particular aircraft. Further, BRP-Rotax grants no warranty on this engines suitability with any other part, component or system which may be selected by the aircraft manufacturer, assembler or user for aircraft application

⚠ WARNING

Non-compliance can result in serious injuries or death!

For each use of DAY VFR, NIGHT VFR or IFR in an aircraft the applicable legal requirements and other existing regulations must be adhered to.

- In addition to observing the instructions in our Manual, general safety and accident precautions, legal regulations and regulations of any aeronautical authority must be observed
- Where differences exist between this Manual and regulations provided by any authority, the more stringent regulation shall be applied
- For continued airworthiness see Maintenance Manual Line (MML)
- Unauthorized modifications of engine or aircraft will automatically exclude any liability of the engine manufacturer for consequential damage

BRP-Rotax

INSTALLATION MANUAL

- Engine operation**
- The engine must always be operated according to the content of the latest Operators Manual (OM)
 - To eliminate the risk of injury or damage, ensure any loose equipment or tools are properly secured before starting the engine
 - The use of propellers and their fastenings which exceed the specified values of moment of inertia and imbalance is not allowed and releases the engine manufacturer from any liability
 - Improper engine installation, use of unsuitable piping for fuel, cooling and lubrication system and use of unsuitable wiring for electric and engine management system releases the engine manufacturer from any liability

BRP-Rotax INSTALLATION MANUAL

INSTRUCTION

Engines require instructions regarding their installation, application, use, operation, maintenance and repair.

Technical documentation and regulations are useful and necessary complementary elements for trainings, but can by no means substitute for theoretical and practical instructions.

These instructions should cover explanation of the technical context, advice for operation, maintenance, installation, use and operational safety of the engine.

Safety notice

In this technical Manual passages concerning safety are especially marked. Pass on safety warnings to other users!

Accessories

This engine must only be operated with accessories supplied, recommended and released by BRP-Rotax. Modifications are only allowed after consent of the engine manufacturer.

Spare parts



See Illustrated Parts Catalog (IPC), latest issue for the respective engine type.

NOTICE

Only use GENUINE ROTAX® spare parts. Spare parts must meet the requirements defined by the engine manufacturer. This can only be guaranteed when using spare parts and/or accessories. Spare parts are available at Authorized Distributors and their independent Service Centers. Any warranty by will become void if spare parts and/ or accessories other than spare parts and/or accessories are used (see latest Warranty Conditions).

See relevant Service Letter on www.flyrotax.com.

Standard tools / Special tools

NOTICE

Only use tools and appliances which are suitable for the relevant task according to the latest Manuals.

State of delivery

⚠ WARNING

Engine and gearbox are delivered in “dry“ conditions (without fuel, oil and coolant).

Before putting the engine into operation it must be filled with oil and cooling liquid. Use only oil and coolant as specified.



See latest Operators Manual (OM) and Service Instruction SI-915 i-001 “Selection of suitable operating fluids“, current issue.

BRP-Rotax INSTALLATION MANUAL

TECHNICAL DOCUMENTATION

These documents form the instructions ensuring continued airworthiness of ROTAX® aircraft engines.

The information contained herein is based on data and experience that are considered applicable for authorized mechanics (iRMT, see MML, Chapter 05–00–00 section “Authorized Personnel”) under normal conditions for engine removal and installation. Concerning design of engine installation in depth knowledge of aircraft design is required.

Due to the fast technical progress and fulfillment of particular specifications of the customers it may occur that existing laws, safety prescriptions, constructional and operational regulations may not be sufficient or cannot be transferred completely to the object bought, in particular for special constructions.

Documentation

- Installation Manual (IM)
- Operators Manual (OM)
- Maintenance Manual Line (MML)
- Maintenance Manual Heavy (MMH)
- Overhaul Manual (OHM)
- Illustrated Parts Catalog (IPC)
- Alert Service Bulletin (ASB)
- Service Bulletin (SB)
- Service Instruction / Service Instruction-Parts and Accessories (SI-PAC)
- Service Letter (SL)



Status

The status of the Manuals can be determined by checking the table of amendments. The first column of this table indicates the revision status, which should be compared with the revision provided on the ROTAX®-Website: www.FLYROTAX.com
Amendments and current versions can be downloaded free of charge.

Replacement pages

Furthermore the Manual is constructed in such a way that single pages can be replaced instead of the complete document. The list of affected pages is given in the chapter LEP. The particular edition and revision number is given on the footer of each page.

Reference

This Manual is only part of the technical documentation and will be supplemented by the respective Operators Manual (OM), Maintenance Manuals and Illustrated Parts Catalog (IPC).

NOTICE

Pay attention to references to other documentation, found in various parts of this Manual.

If not stated otherwise, any reference to a document refers to the latest edition issued by BRP-Rotax.

BRP-Rotax INSTALLATION MANUAL



This symbol informs you of additional references (data sheets, Manuals, etc.) associated with the given subject.

Illustrations

The illustrations in this Manual are merely sketches and show typical arrangements. They may not represent full detail or the exact shape of the parts but should outline the same or similar function. Therefore deriving dimensions or other details from illustrations is not permitted.

TYPICAL indicates a general view which may not represent exact details.

NOTE

The Illustrations in this Manual are stored in a graphic database system and are provided with a consecutive, irrelevant, number.

This number (e.g. AE 5iS001) is of no significance for the content.

Some measurements are given in the drawings, these are manufacturing dimensions and are subject to corresponding tolerances.

Installation drawings

Installation drawings and a “digital mock-up (DMU) model” for (virtual) installation analysis are available from the ROTAX® Authorized Distributors or their independent Service Centers on special request and relevant non disclosure and copyright regulations.

The illustrations in this Manual show a possible installation variant including non certified parts.

BRP-Rotax
INSTALLATION MANUAL

APPROVAL OF ELECTRIC AND ELECTRONIC COMPONENTS
(EQUIPMENT QUALIFICATION ACCORDING TO RTCA/DO-160)

RTCA/DO-160 defines a series of minimum standard environmental test conditions and applicable test procedures for airborne equipment. The purpose of these tests is to provide a laboratory means of determining the performance characteristics of airborne equipment in environmental conditions representative of those which may be encountered in airborne operation of the equipment.

Electric and Electronic components (incl. wiring harness, ECU, Fuse Box, PMA, Sensors and Actuators) of the 915 i A Series are considered as part of the equipment and have been tested and qualified according to the following table:

DO-160G, Section 4 — Temperature and Altitude	Cat. B3V ¹
DO-160G, Section 5— Temperature Variation	Cat. B
DO-160G, Section 6— Humidity	Cat. B
DO-160G, Section 7— Operational Shocks and Crash Safety	Cat. BD
DO-160G, Section 8 — Vibration	Cat. S (L)
DO-160G, Section 9— Explosion Proofness	Test not performed
DO-160G, Section 10 — Water Proofness	Cat. S
DO-160G, Section 11 — Fluids Susceptibility	Cat. F
DO-160G, Section 12 — Sand and Dust	Cat. D
DO-160G, Section 13 — Fungus Resistance	Test not performed
DO-160G, Section 14 — Salt Spray	Cat. S
DO-160G, Section 15 — Magnetic Effect	Cat. A
DO-160G, Section 16 — Power Input	Cat. BXX
DO-160G, Section 17 — Voltage Spike	Cat. A
DO-160G, Section 18 — AF Cond. Susceptibility	Cat. Z
DO-160G, Section 19 — Induced Signal Susceptibility	Cat. ZCX
DO-160G, Section 20 — RF Susceptibility Conducted DO-160G, Section 20 — RF Susceptibility Radiated	Cat. M Cat. D
DO-160G, Section 21 — Emission RF Energy Conducted DO-160G, Section 21 — Emission RF Energy Radiated	Cat. B Cat. B
DO-160G, Section 22 — Lightning Induced Trans. Suspectibility	Cat. B3H3L3
DO-160G, Section 23 — Lightning Direct Effects	Test not performed

-
1. Components were tested at „operating low temperature“ of - 40 °C (- 40 °F) instead of - 45 °C (- 49 °F).

BRP-Rotax INSTALLATION MANUAL

DO-160G, Section 24 — Icing	Test not performed
DO-160G, Section 25 — Electrostatic Discharge	Cat. A

**Component
surface tem-
perature
limits**

System Limit	Min.	Max.
ECU	- 40 °C (- 40 °F)	80 °C (176 °F)
EGT Sensors (electronic box)	- 40 °C (- 40 °F)	80 °C (176 °F)
Fusebox	- 40 °C (- 40 °F)	80 °C (176 °F)
AC-DC Converter assy.	- 40 °C (- 40 °F)	80 °C (140 °F)

BRP-Rotax
INSTALLATION MANUAL

Chapter: 10-10-00
STORAGE AND INSTALLATION

TOPICS IN THIS CHAPTER

Special tools.....3

General.....4

 Engine storage4

 Unpacking the engine5

 Engine handling7

BRP-Rotax
INSTALLATION MANUAL

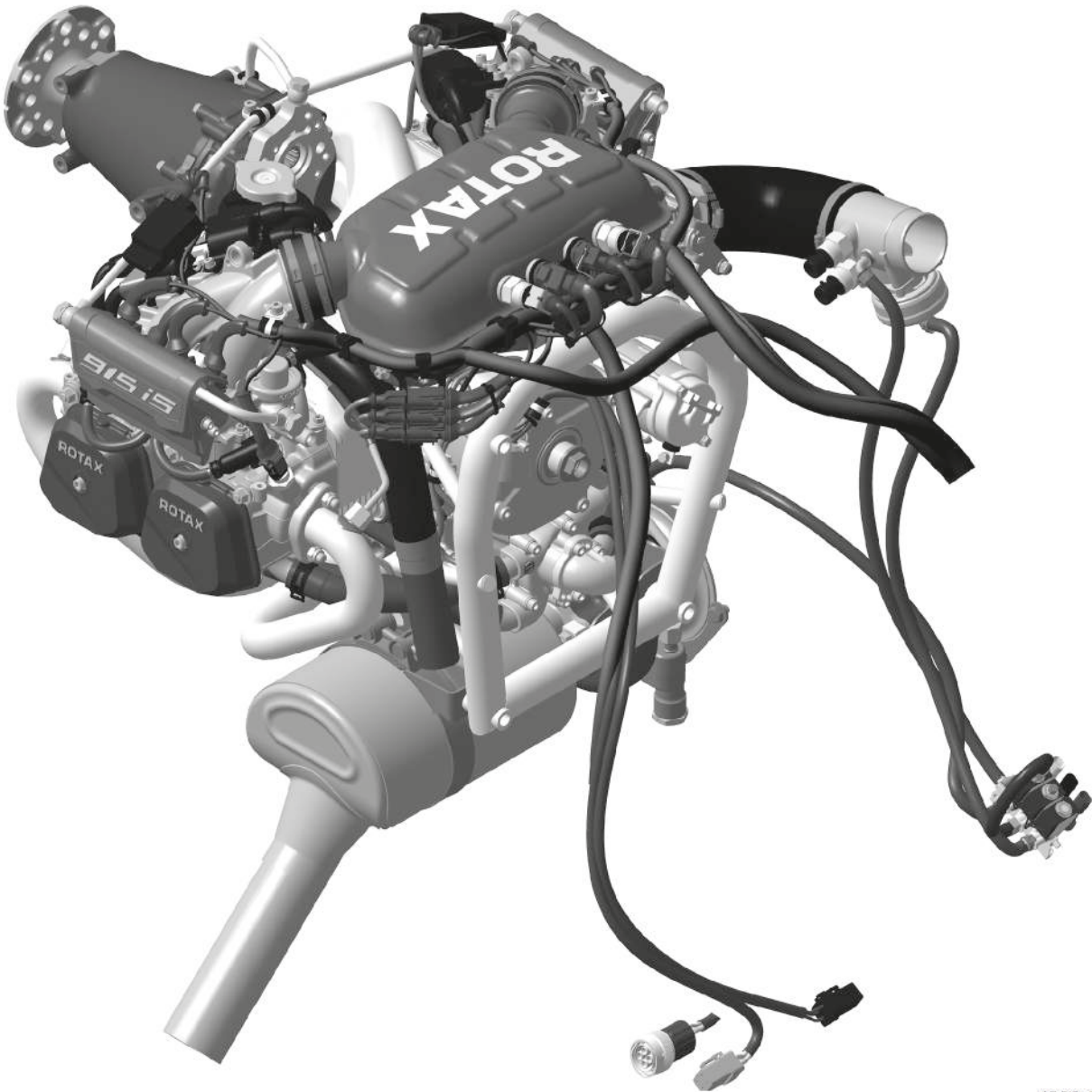

AE 515_0158

Figure 2.1: 915 iS engine TYPICAL

BRP-Rotax
INSTALLATION MANUAL

SPECIAL TOOLS

Description	Part number
Engine lift set	876040

BRP-Rotax INSTALLATION MANUAL

GENERAL

NOTICE

Risk of consequential damage to engine and aircraft as a result of corrosion and damage. Under no circumstances is a corroded or damaged engine to be installed in an aircraft!

ENGINE STORAGE

The engine is preserved at BRP-Rotax thus guaranteeing proper protection against corrosion damage for at least 12 months after the date of delivery from BRP-Rotax.

This warranty is subject to the following conditions:

- The engine must be stored in the GENUINE-ROTAX®-packing as supplied by BRP-Rotax.
- The covers on various openings must not be removed
- The engine must be stored in a suitable place (at min. -40 °C/-40 °F and max. +80 °C/176 °F)
- The bag (blue) surrounding the engine must not be damaged or removed, as it protects the engine from corrosion and oxidation

If the engine is stored for a period longer than 12 months (or it is not stored in the GENUINE-ROTAX®-packing) then maintenance tasks must be carried out every 3 months as per the currently valid Maintenance Manual Line.

General note All general inspection, maintenance and repair has to be carried out in accordance with Advisory Circular AC 43.13 from FAA.

Advisory Circular This Manual "Advisory Circular" AC describes maintenance methods, techniques and practice. These are recognized and authorized for inspection and repairs in non-pressurized areas for which there are no separate maintenance and repair instructions.

Corrosion Environmental corrosion (on the external surfaces) is a naturally occurring process which can inevitably affect the continued airworthiness of the engine, engine mounted components and accessories. Susceptibility to corrosion is influenced by a number of factors, including but not limited to, geographical location, season and usage. All general preventive (technical) measures, identification, control and treatment of corrosive attack on aircraft structures and engine materials has to be carried out in accordance with Advisory Circular AC 43-4B from FAA and also in accordance with the information of the aircraft manufacturers Instruction for Continued Airworthiness. Furthermore the preservation procedures for stored and inactive aircraft (engines) provides an effective means for combating and minimizing the corrosion condition and should be adhered to.

Advisory Circular AC 43-4B This advisory circular (AC) is a summary of the current available data regarding identification and treatment of corrosive attack on aircraft structures and engine materials. Corrosion inspection frequency, corrosion identification, and especially corrosion treatment continues to be the responsibility of the operator. These inspections should be accomplished per this AC, the manufacturer's recommendations, or the operator's own maintenance program. The procedures in this AC are an acceptable

BRP-Rotax INSTALLATION MANUAL

means, but not the only acceptable means, of corrosion treatment. The information in this AC is applicable to aircraft for which the manufacturer has not published corrosion control information.

UNPACKING THE ENGINE

NOTICE

The attachment screws are only for transport and must not be used in the aircraft.

NOTICE

During engine installation take into account the total engine weight and ensure careful handling.

Unpacking the engine

When the engine is delivered, check for damage of the packaging. If the package is damaged, contact a ROTAX® Authorized Distributor or their independent Service Center for ROTAX® aircraft engines.

To unpack a new engine and for checking the state of delivery, proceed as follows:

1. Remove the wooden cover.
2. Remove the bag and protective wrapping around the engine.
3. Check that the serial number and engine type on the type plate are identical to those shown on the delivery note.
If the serial number or the engine type is deviating from the delivery contact a ROTAX® Authorized Distributor- or their independent Service Center for ROTAX® aircraft engines.
4. Check the engine for damage or corrosion.
If the engine is damaged or corroded, contact a ROTAX® Authorized Distributor- or their independent Service Center for ROTAX® aircraft engines.
5. Screw off the transport bracket screws from wooden bottom of the box.
6. Remove transport brackets from engine.

Protective coverings

NOTICE

Protective coverings are only for use during transport and engine installation. They must be removed completely (including sealing materials) before the engine is operated.

All openings are protected against ingress of contamination and dampness. It is recommended to leave the protective plugs in place until installation of the specific feed line.

The protective coverings can be found at following locations:

BRP-Rotax INSTALLATION MANUAL

Pos.	Installation location	Amount
1	Exhaust pipe (tail pipe)	
2	Fuel rail (outlet) / fuel pressure regulator	
3	Fuel rail (inlet)	
4	Oil inlet/outlet and oil return turbo (oil pump)	
5	Coolant inlet/outlet	
6	Throttle body socket assy.	
7	Air intake socket on turbocharger	
8	Wastegate	
9	Propeller shaft	
10	Cover plate hydraulic governor (if configuration 3)	
11	Oil return turbo (governor flange)	

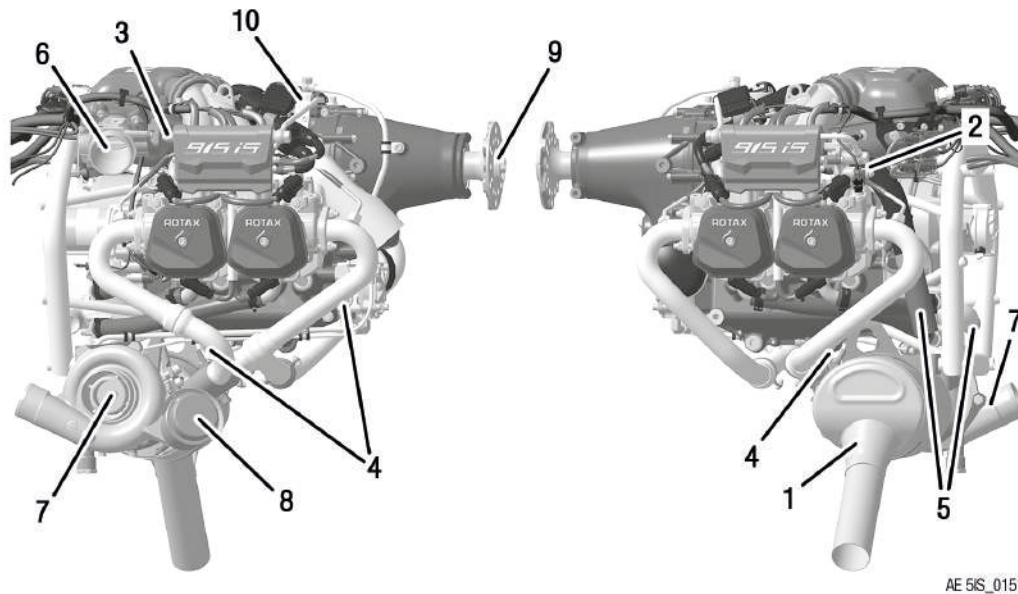

Figure 2.2: Protective covering positions

- | | |
|--|---|
| <p>1 Exhaust pipe</p> <p>3 Fuel rail (inlet)</p> <p>5 Coolant inlet/outlet</p> <p>7 Air intake socket on turbocharger</p> <p>9 Propeller shaft</p> | <p>2 Fuel (outlet) /fuel pressure regulator</p> <p>4 Oil inlet/outlet and oil return turbo</p> <p>6 Throttle body socket assy.</p> <p>8 Wastegate</p> <p>10 Cover plate governor (if configuration 3)</p> |
|--|---|

BRP-Rotax INSTALLATION MANUAL

ENGINE HANDLING

NOTICE

Do not use the fuel lines or the wiring harness for lifting the engine!

Attachment points

The engine may only be lifted on the dedicated attachment points by using the GENUINE-ROTAX®- engine lift set and a spreader bar with 350 mm (13.78 in) distance between lifting points. Make sure that lifting device does not bend the attachment lugs by relevant force distribution.

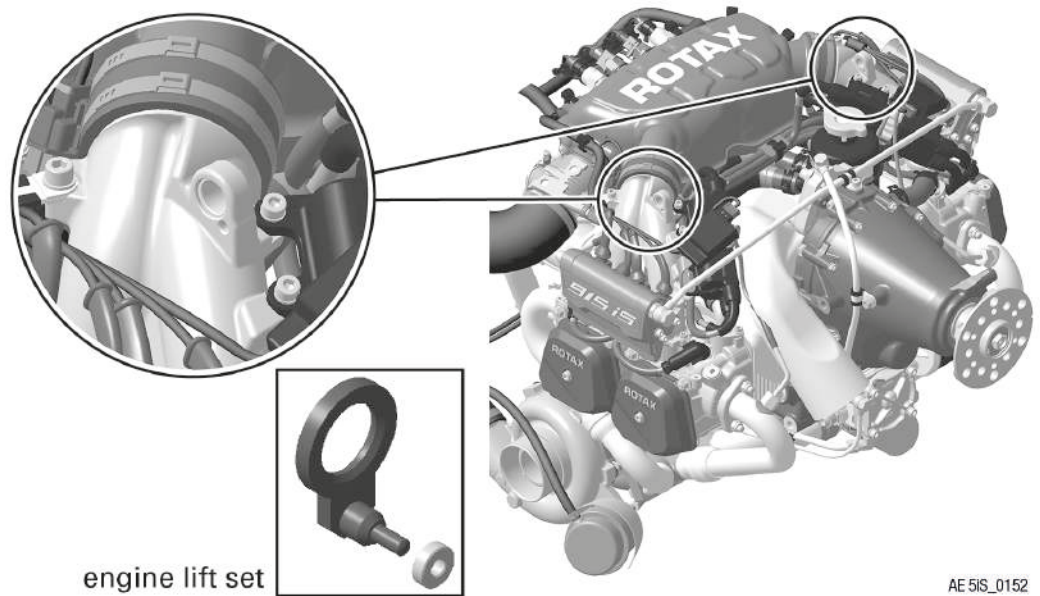

Figure 2.3: Attachment points

BRP-Rotax
INSTALLATION MANUAL

INTENTIONALLY LEFT
BLANK

BRP-Rotax
INSTALLATION MANUAL

Chapter: 24-00-00
ELECTRICAL POWER

TOPICS IN THIS CHAPTER

System description	4
System limitations	4
Interface description– 915 I Type A	6
Interface overview	6
Electrical interfaces	6
Mechanical interfaces	11
Interface description– 915 I Type C24	12
Interface overview.– 915 I Type C24	12
Electrical interfaces – 915 I Type C24	12
Mechanical interfaces – 915 I Type C24	18
Installation notes	20
Installation overview	20
Grounding cables	20
Battery	21
Control elements	22
Validation of installation	26

BRP-Rotax INSTALLATION MANUAL

915 i TYPE A

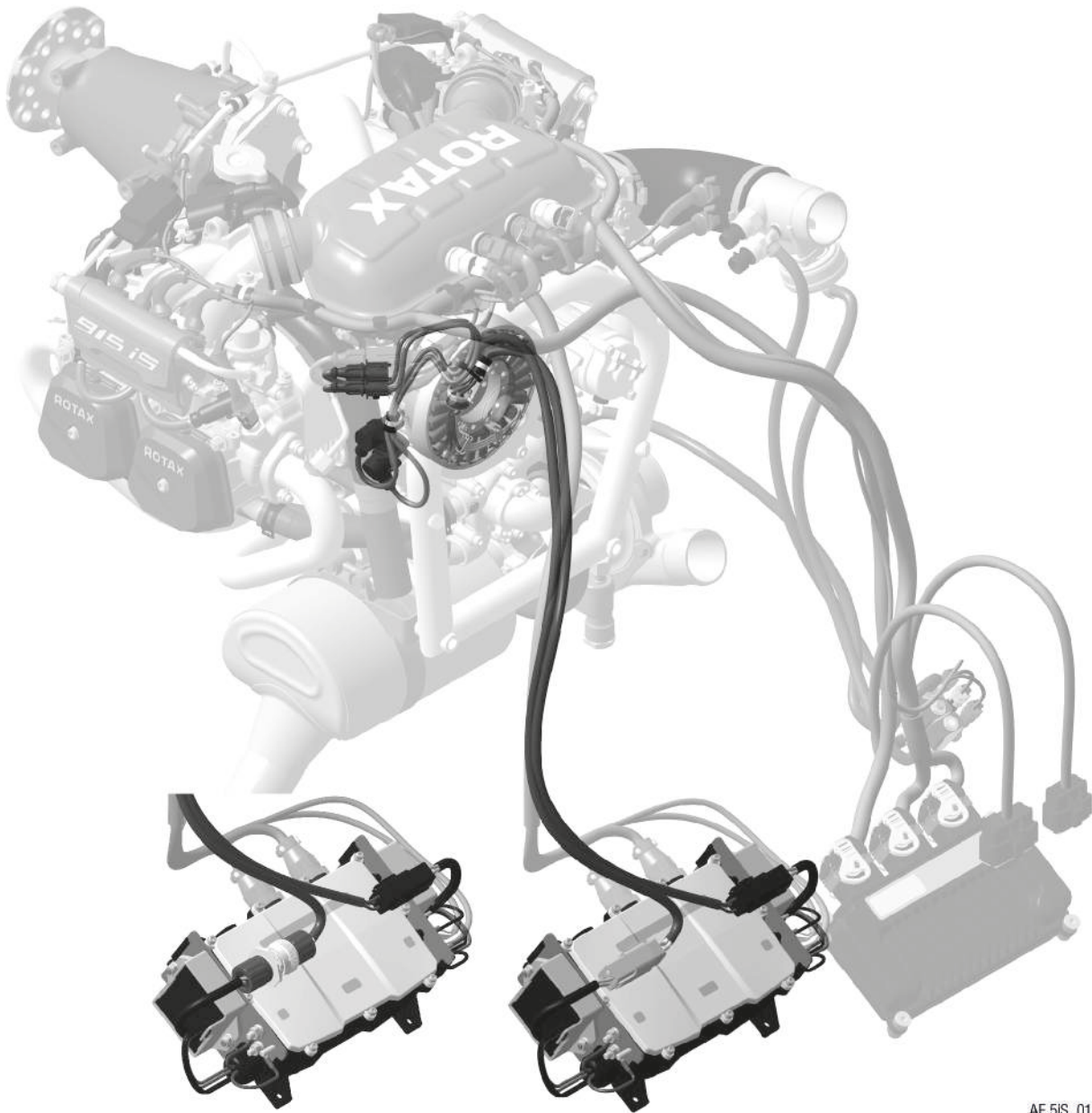

AE 51S_0153a

Figure 3.1: Internal power supply

BRP-Rotax
INSTALLATION MANUAL

915 i TYPE C24

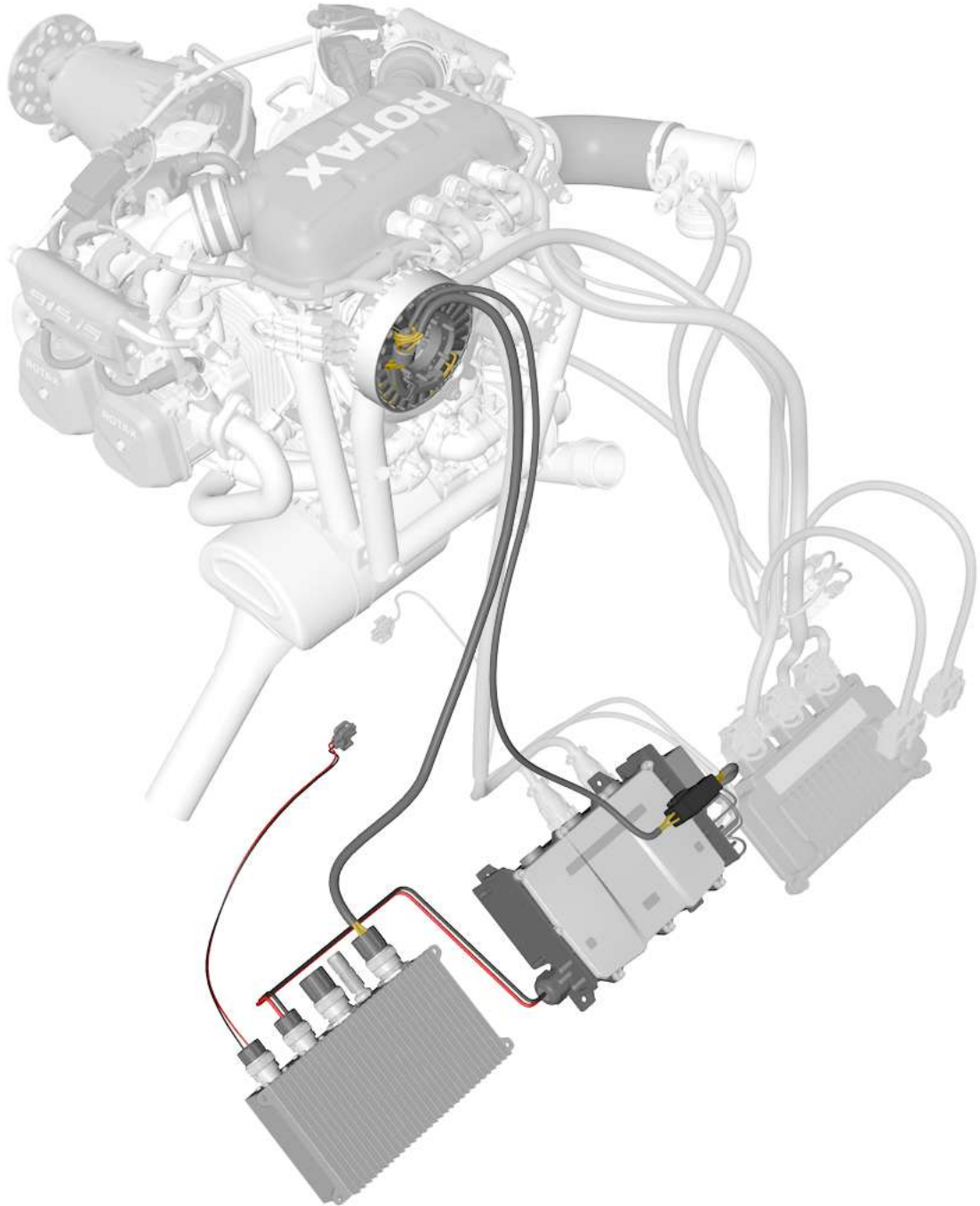

Figure 3.2: Internal power supply

BRP-Rotax INSTALLATION MANUAL

SYSTEM DESCRIPTION

For a detailed system description refer to the latest issue of the Operators Manual (OM).

SYSTEM LIMITATIONS

NOTICE

Consumer cables must NOT be routed alongside the ignition cables. There is a risk of electromagnetic interference.

Valid installation positions

The Fusebox must not be installed in the cockpit. Installation is only allowed in the engine compartment.

Component temperatures limitation

Limitations see Chapter 00-00-00 Approval of electric and electronic components.

The Regulator temperature must be measured as shown within the following figure:

915 i TYPE A

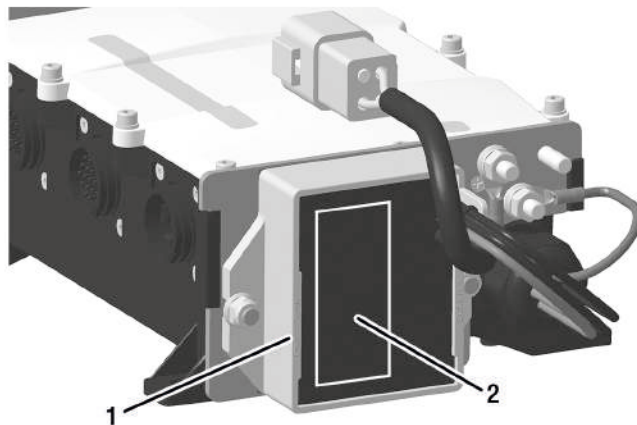

AE 5IS_0003

Figure 3.3: Regulator temperature measurement area TYPICAL

1 Rectifier regulator

2 Component temperature measurement area

BRP-Rotax INSTALLATION MANUAL

915 i TYPE C 24

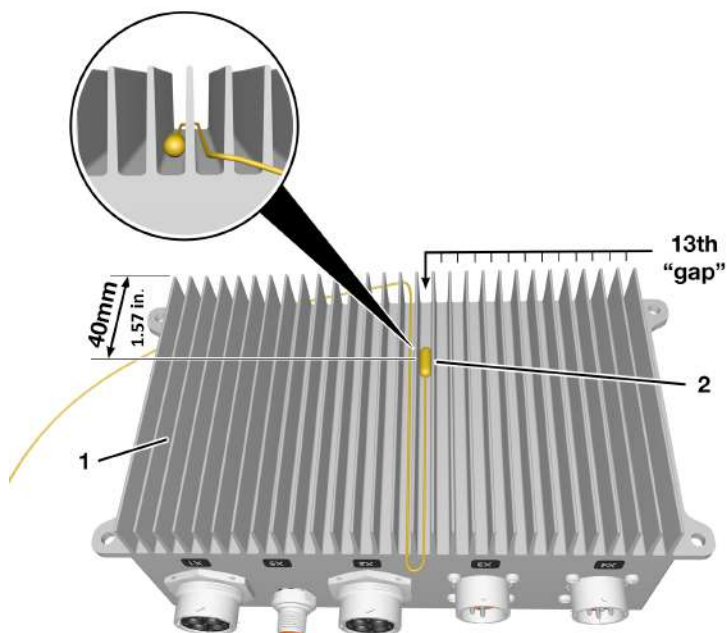

Figure 3.4: Regulator temperature measurement area

1 28 V AC-DC Converter assy.

2 Component temperature measurement area

Separation of EMS and Airframe circuit

A connection between regulator plate A (EMS ground) and airframe ground should only be done during supply of the EMS System by an external power source (e.g. during engine start). Although it would have no impact on the redundancy of the EMS, the fault tolerance of the system will be degraded if the EMS ground is connected permanently with the airframe ground.

BRP-Rotax
INSTALLATION MANUAL

INTERFACE DESCRIPTION– 915 I TYPE A

INTERFACE OVERVIEW

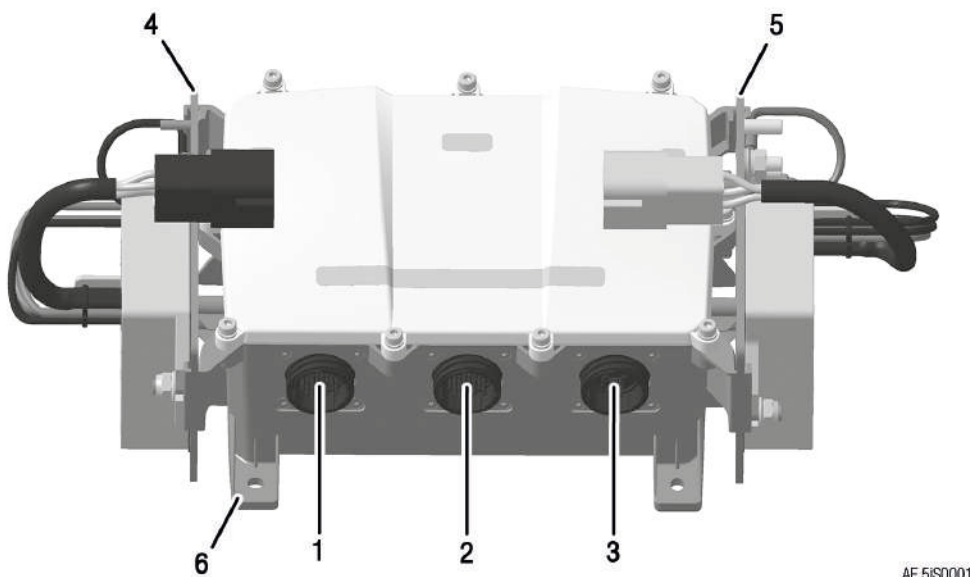

AE 5IS0001

Figure 3.5: Fusebox connections

- | | | | |
|---|--|---|--|
| 1 | X1 Connector (electrical interface) | 2 | X2 Connector (electrical interface) |
| 3 | X3 Connector (electrical. interface) | 4 | Regulator Plate A (electrical interface) |
| 5 | Regulator Plate B (electrical interface) | 6 | Fusebox mounting points (mechanical interface) |

ELECTRICAL INTERFACES

The seals supplied with the Fusebox must be inserted into the X1, X2 and X3 Connector (Fusebox side) to enable a good connection between plug and socket and thus avoid unnecessary vibrations and misalignment of connector pins.

Fusebox –X1, X2 Connector

The X1 and X2 ensure the power distribution to the EMS System. Both plugs must be connected with mating sockets on the (engine-) wiring harness. The connectors are not interchangeable and are marked on the wiring harness side.

Fusebox–X3 Connector

For information on the X3 Connector, see the relevant SI-PAC-012.

BRP-Rotax INSTALLATION MANUAL

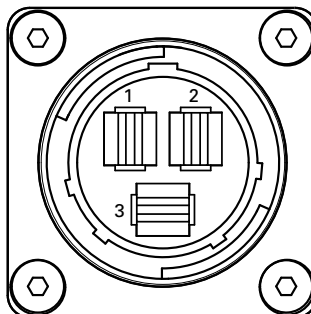

AE 5iS_0372

Figure 3.6: X3-Connector: Fusebox side

- 1 Terminal 1
- 2 Terminal 2
- 3 Terminal 3

Terminal 1 enables the EMS to be supplied with an external power source (e.g. in case the internal power supply fails supplying the EMS). Terminal 2 enables powering the EMS during engine start (until the engine speed is high enough that the internal generator is able to supply the EMS). Terminal 3 can be used for supplying the Airframe with electrical energy after generator A has taken over powering the EMS.

Terminal	Interface Parameter	Min.	Max.	Nominal
1	Input voltage:	9 V ²	14.5 V	12 V
	Input load:		230 W DC cont. 290 W DC peak	
2	Input: voltage:	9 V	14.5 V	12 V
	Input load:		230 W DC cont. 290 W DC peak	
3	Output voltage:	13.9 V	14.5 V	14.2 V
	Output capacity:		max. 420 W DC (at 20°) (68 °F) see section performance diagram	

-
2. This limit must also be considered when the starter motor is actuated

BRP-Rotax INSTALLATION MANUAL

NOTICE

In failure conditions the output voltage can exceed the specified limits.

The following measurement is taken at an oil temperature of 135 °C (275 °F).

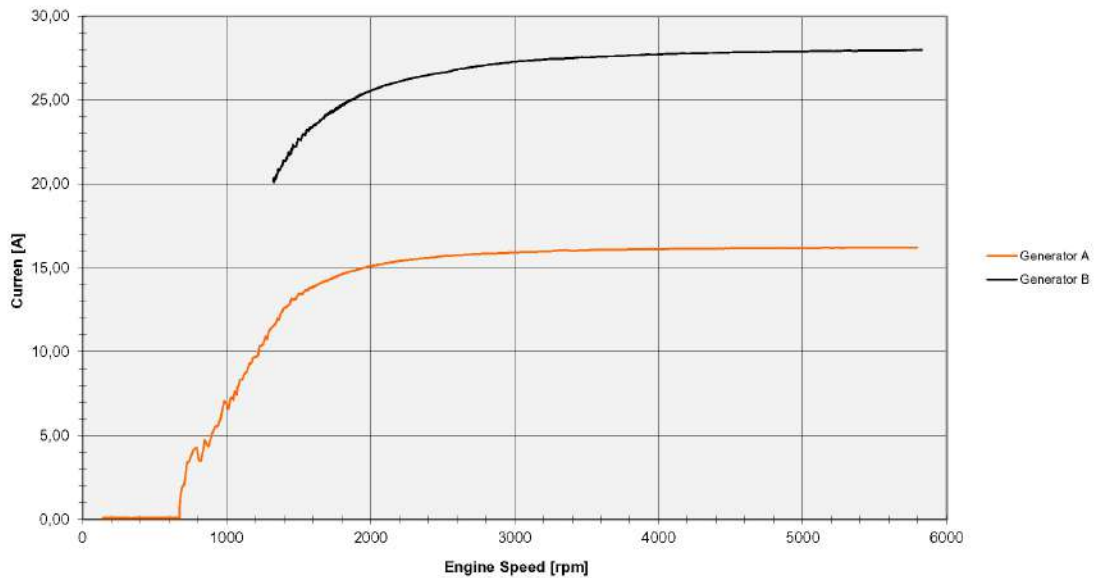

Figure 3.7: Characteristic curve of internal generators

BRP-Rotax INSTALLATION MANUAL

Fusebox Regulator A

The regulator plate A needs to be connected with the EMS Ground (ring terminals on the (engine-) wiring harness). The stud has M4 threads suitable for ring terminals according to DIN 46225 or MS25036– 149 (size #8) (tightening torque: 1.2 Nm / 11 in lb). The ring terminals need to be evenly spread onto the three available studs.

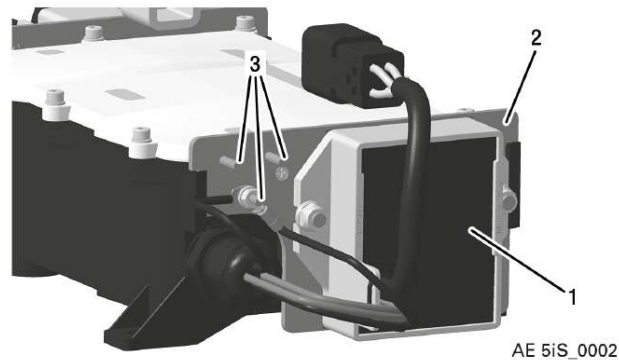

Figure 3.8: Fusebox -Regulator A

1 Regulator

2 Regulator plate A

3 Ground studs

NOTICE

A connection between regulator plate A and airframe ground should only be done during supply of the EMS System by an external power source (e.g. during engine start).

BRP-Rotax INSTALLATION MANUAL

Fusebox Regulator B

The Regulator B needs to be connected with the Airframe Ground. The stud has M6 threads suitable for ring terminals according to DIN 46225 or MS25036 (1/4" PIDG) (tightening torque: 5.9 Nm / 52 in lb).

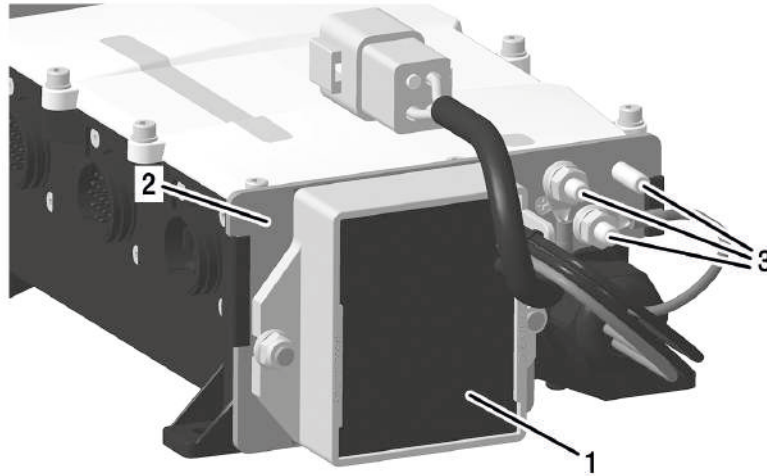

AE 5IS0003

Figure 3.9: Fusebox -Regulator B – TYPICAL

- 1 Regulator
- 2 Regulator plate B
- 3 Ground terminals

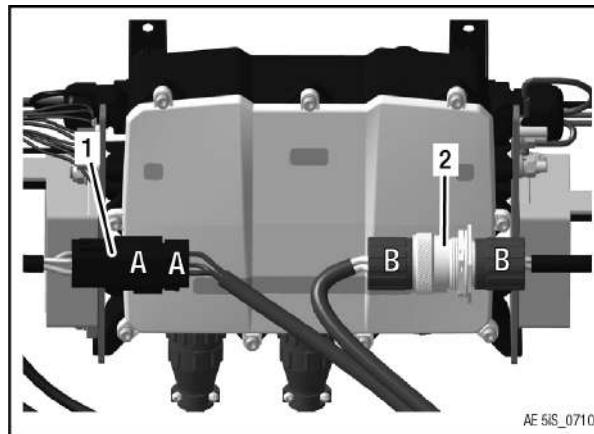

AE 6IS_0710

Figure 3.10: Fusebox – Regulator B with Amphenol connector

- 1 Connector Regulator A
- 2 Amphenol connector Regulator B

BRP-Rotax INSTALLATION MANUAL

MECHANICAL INTERFACES

Fusebox mounting points

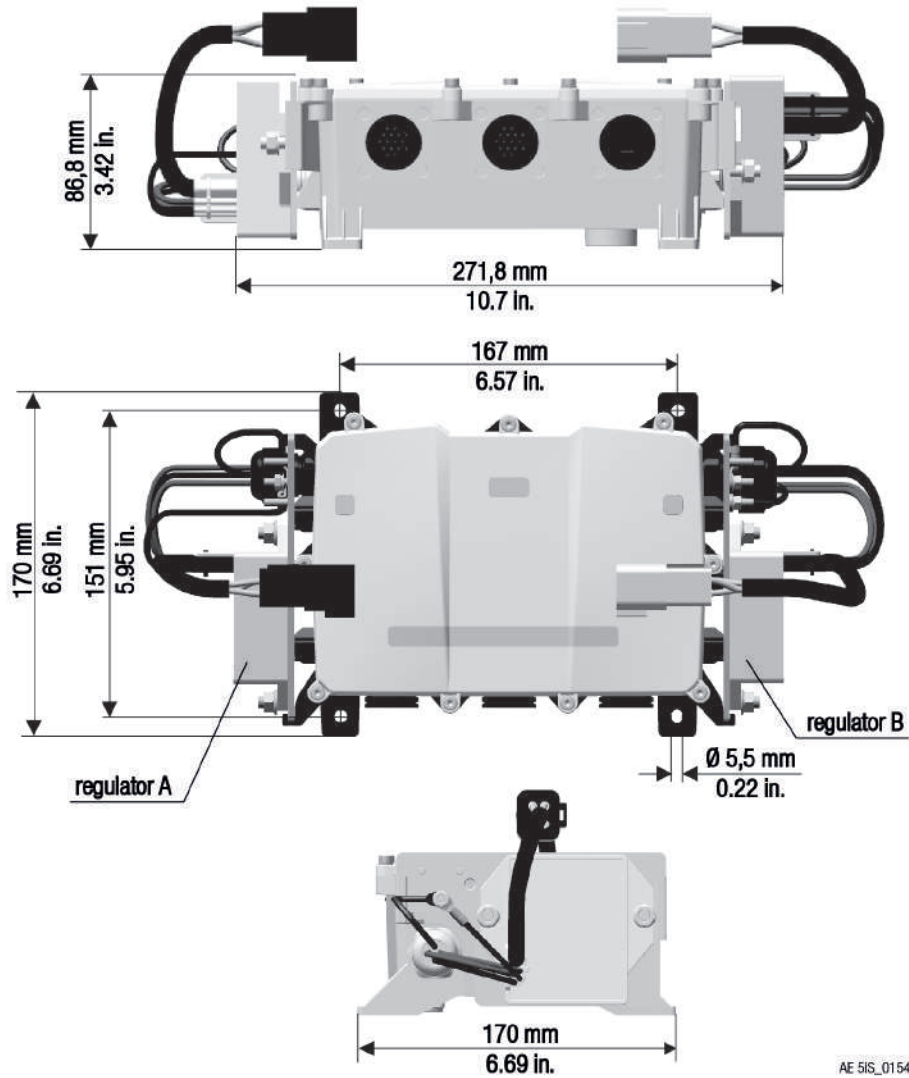

AE 5IS_0154

Figure 3.11: Fusebox –Connections and dimensions – TYPICAL

INTERFACE DESCRIPTION– 915 I TYPE C24

INTERFACE OVERVIEW.– 915 I TYPE C24

915 i TYPE C 24

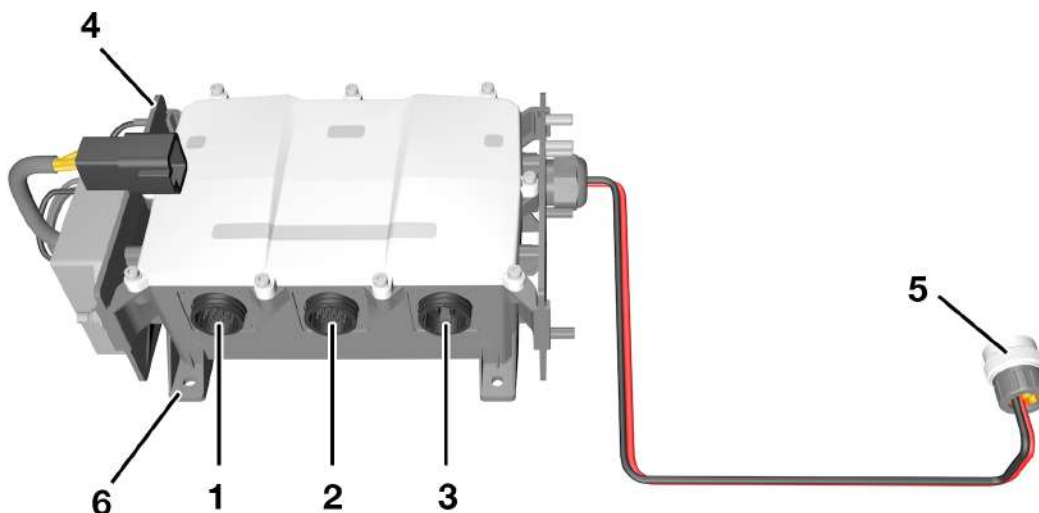

Figure 3.12: Fusebox connections

- | | | | |
|---|---|---|--|
| 1 | X1 Connector (electrical interface) | 2 | X2 Connector (electrical interface) |
| 3 | X3 Connector (electrical. interface) | 4 | Regulator Plate A (electrical interface) |
| 5 | Connector to 28 V AC-DC Converter assy. | 6 | Mounting points |

ELECTRICAL INTERFACES – 915 I TYPE C24

915 i TYPE C24

The seals supplied with the Fusebox must be inserted into the X1, X2 and X3 Connector (Fusebox side) to enable a good connection between plug and socket and thus avoid unnecessary vibrations and misalignment of connector pins.

Fusebox –X1, X2 Connector

The X1 and X2 ensure the power distribution to the EMS System. Both plugs must be connected with mating sockets on the (engine-) wiring harness. The connectors are not interchangeable and are marked on the wiring harness side.

Fusebox – X3 Connector

Terminal 1 enables the EMS to be supplied with an external power source (e.g. in case the internal power supply fails supplying the EMS).

BRP-Rotax
INSTALLATION MANUAL

Terminal	Interface Parameter	Min.	Max.	Nominal
1	Input voltage:	9 V ³	14.5 V	12 V
	Input load:		230 W DC cont. 290 W DC peak	
2	Plugged, do not pierce the plug seal.			
3	Plugged, do not pierce the plug seal.			

NOTICE

In failure conditions the output voltage can exceed the specified limits.

-
3. This limit must also be considered when the starter motor is actuated

BRP-Rotax INSTALLATION MANUAL

Fusebox Regulator A

The regulator plate A needs to be connected with the EMS Ground (ring terminals on the (engine-) wiring harness). The stud has M4 threads suitable for ring terminals according to DIN 46225 or MS25036-149 (size #8) (tightening torque: 1.2 Nm / 11 in lb). The ring terminals need to be evenly spread onto the three available studs.

915 i TYPE C24

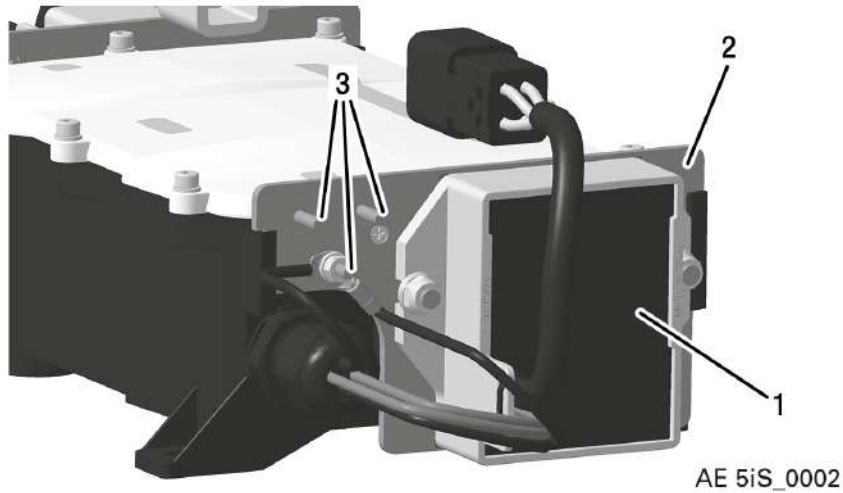

Figure 3.13: Fusebox -Regulator A

1 Regulator

2 Regulator plate A

3 Ground studs

NOTICE

A connection between regulator plate A and airframe ground should only be done during supply of the EMS System by an external power source (e.g. during engine start).

BRP-Rotax INSTALLATION MANUAL

Fusebox

The Fusebox needs to be connected with the 28 V AC-DC Converter assembly.

915 i TYPE C24

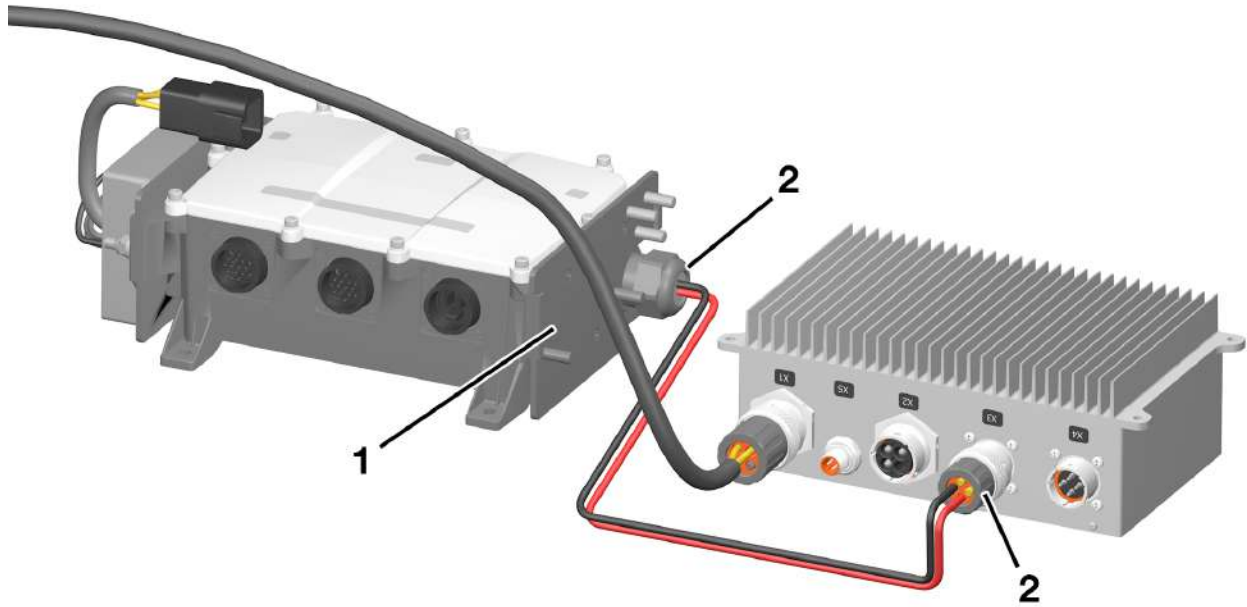

Figure 3.14

1 Fusebox

2 Connector to 28 V AC-DC Converter
assy.

BRP-Rotax INSTALLATION MANUAL

28 V AC-DC CON-
VERTER ASSY.

915 i TYPE C24

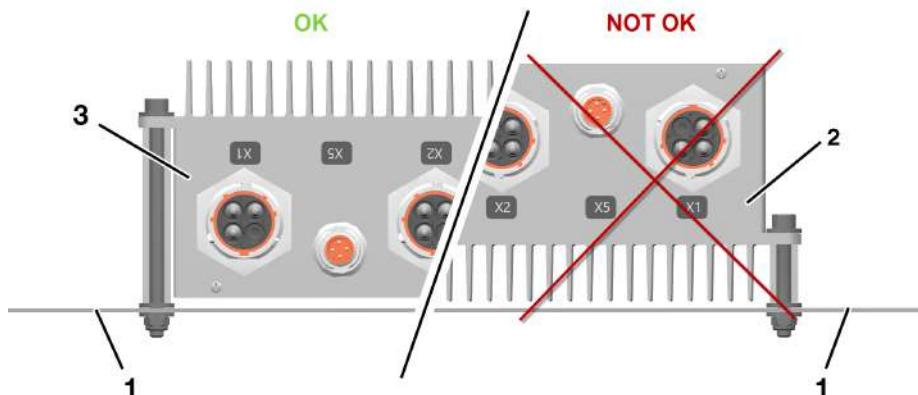

Figure 3.15: 28 V AC-DC Converter Assy.

- 1 Firewall
- 2 Orientation of the heat sink NOT to the firewall
- 3 Orientation of the heat sink to the firewall

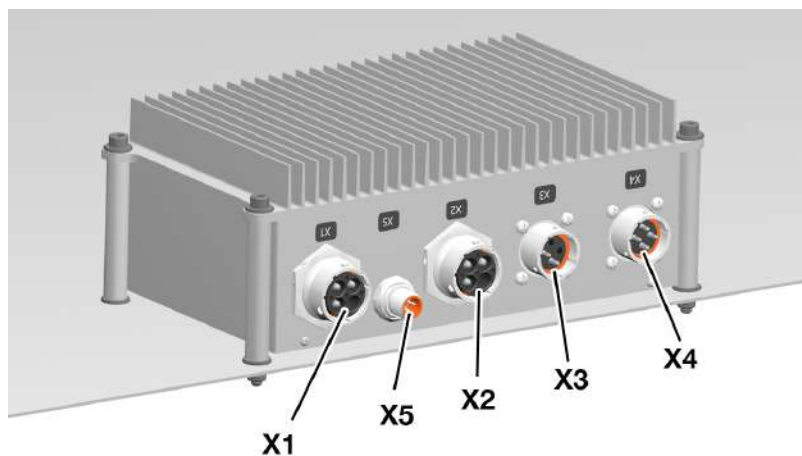

Figure 3.16: 28 V AC-DC Converter Assy.

- X1 Generator B (stator cable from ignition housing)
- X2 Aircraft 28 V Bus / Battery 24 V
- X3 Generator B (connector from Fusebox)
- X4 Cockpit Airframe side
- X5 See Chapter 77-00-00

BRP-Rotax
INSTALLATION MANUAL

Generator B (stator cable from ignition housing)

Connector	PIN	Function	Type
X1	A	Phase 1 of Generator	Input
	B	Phase 2 of Generator	Input
	C	Phase 3 of Generator	Input

Aircraft 28 V Bus / Battery 24 V

Connector	PIN	Function	Type
X2	A	28 V (output for Aircraft)	Output
	B	28 V GND (output for Aircraft)	Output
	C	+24 V (Aircraft Battery Plus Pol)	Input

Generator B (connector from Fusebox)

Connector	PIN	Function	Type
X3	A	14 V (for EMS, connected at Fusebox B Minus Pol)	Output
	B	14 V GND (for EMS, connected at Fusebox B Minus Pol)	Output

Cockpit Airframe side

Connector	PIN	Function	Type
X4	A	14 V (for EMS, Battery Backup)	Output
	B	14 V GND (for EMS, Battery Backup)	Output
	C	14 V (for Fuel Pump 2 / Aux.)	Output
	D	14 V GND (for Fuel Pump 2 / Aux)	Output
X5		See Chapter 77-00-00.	

BRP-Rotax INSTALLATION MANUAL

MECHANICAL INTERFACES – 915 I TYPE C24

Fusebox and
Converter assy.
mounting points

915 i TYPE C 24

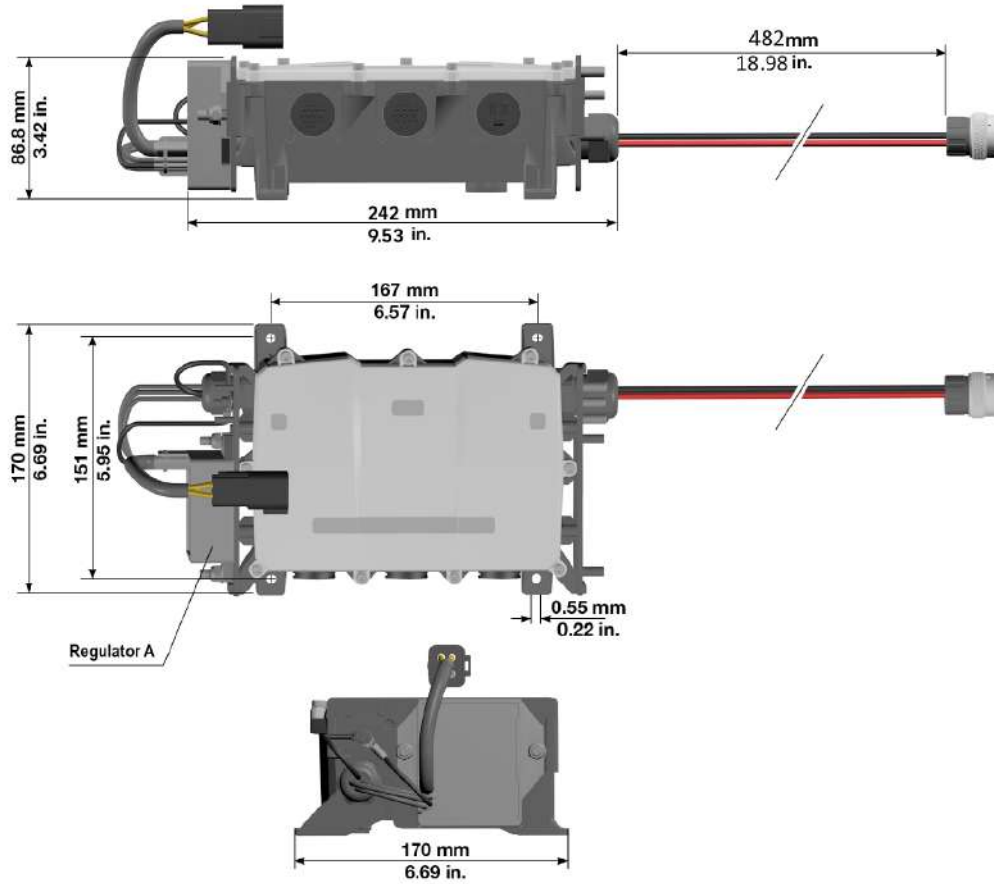

AE_5iS_0826

Figure 3.17: Fusebox –Connections and dimensions

BRP-Rotax
INSTALLATION MANUAL

915 i TYPE C 24

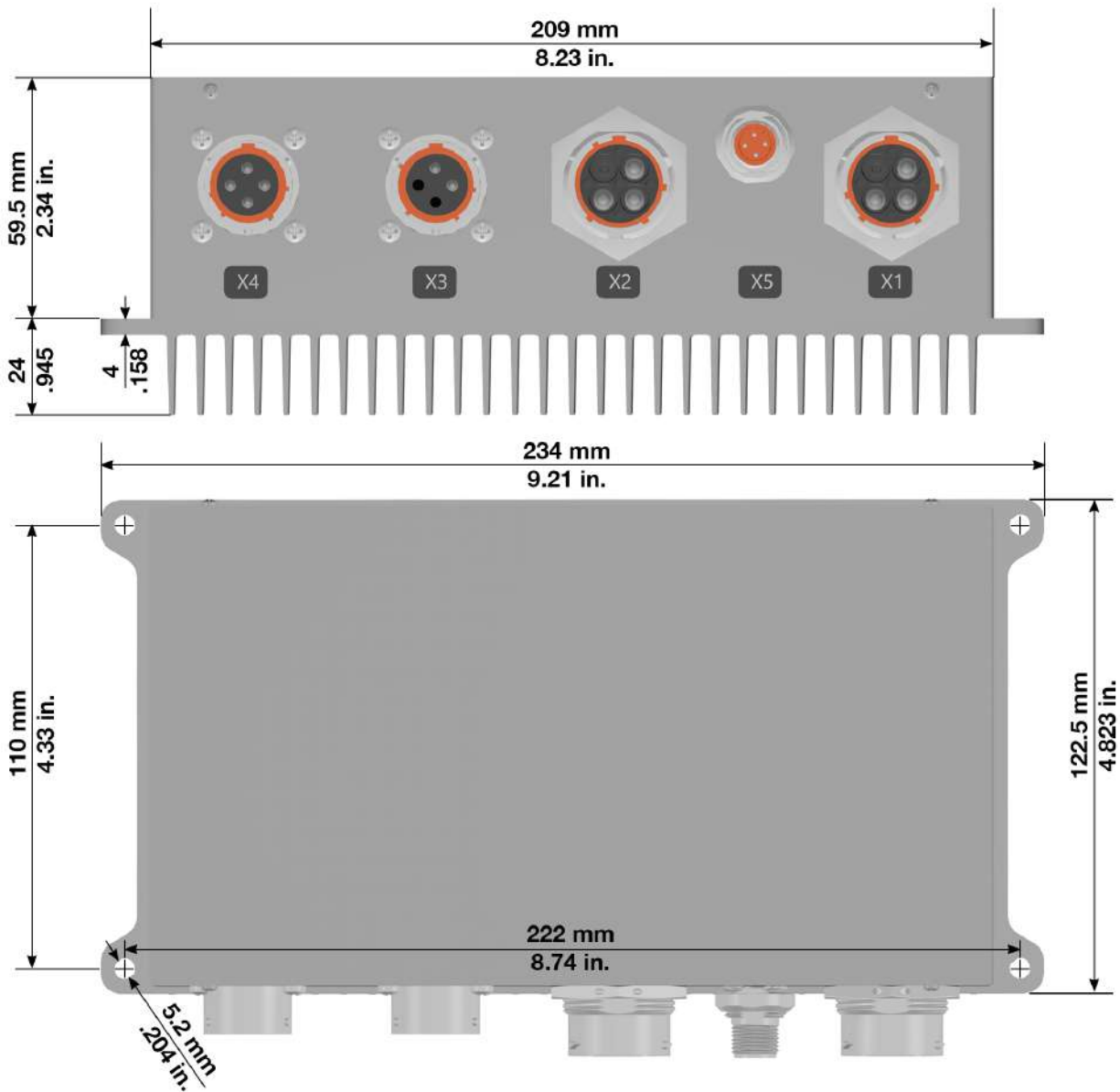

Figure 3.18: 28 V Converter: Connections and dimensions

NOTE

28 V AC-DC converter need to be installed with connector facing down.

BRP-Rotax INSTALLATION MANUAL

INSTALLATION NOTES

General

The representation of components in this chapter which are not within scope of the delivery is only symbolic. The design shown in this chapter does not represent a specified execution but should support the understanding of the system.

The final design, the selection and specification of parts according to the respective applicable regulations, the consideration of the system limitations and interface description as well as the comprehension of the operating limits in every operational state is in the responsibility of the aircraft manufacturer.

The aircraft manufacturer has to make sure that the operating limits given in the Operators Manual (OM) can be supervised by the pilot. The execution of the installation must allow the operation of the engine according to the Operators Manual (OM).

INSTALLATION OVERVIEW

Wiring diagrams

915 i TYPE A

For improved clarity, see diagrams in Chapter 92-00-00 "Wiring diagrams".

915 i TYPE C24

For improved clarity, see diagrams in Chapter 92-00-00 "Wiring diagrams".

GROUNDING CABLES

The wiring of the grounding cables is an essential point when conducting engine electronics. Following two circuits must be distinguished:

- Airframe circuit
- Engine management system circuit (EMS circuit)

During engine start (dynamic condition, transient), the two circuits are connected to each other.

When the engine is running or when the engine is turned off (and the Fusebox is not supplied with external power), the EMS circuit is electrically isolated from the rest of the aircraft.

Therefore, the following components need to be installed without any contact to the airframe ground:

- ECU
- Regulator A (mounted on Fusebox)
- Starter relay

The engine block must be connected to the airframe using a properly sized ground strap (minimum the same cable cross section as the starter supply but at least 10 mm²), for carrying the starter current and to avoid static electricity between the engine and the airframe.

To gain full lightning strike compliance the rubber shock mounts must be bridged by using ground straps (min. 10 mm²).

BRP-Rotax INSTALLATION MANUAL

BATTERY

NOTICE

The use of rechargeable batteries with lithium-ion technology should only be used in combination with a suitable battery management system. If such a battery is used, the responsibility is up to the aircraft manufacturer. The approval of the relevant aeronautical authority may be necessary. For installation of lithium-ion batteries refer e.g. to FAA AC No: 20-184

The specification of the battery must ensure that during each operating state and also during the transition between two operation states a sufficient supply of the avionics is guaranteed (e.g. during engine start). Depending on the applicable regulations avionics need to be supplied for at least 30 minutes with energy after a failure of the primary power supply in case they are required for safe operation of the aircraft.
If the aircraft is regularly started at temperatures below - 5 °C (23 °F) (ambient- and oil/coolant temperature are below this temperature) it is recommended to provide a connection for an external power supply and a possibility for adequate engine pre-heating.

NOTICE

If all consumers are active, take care not to discharge the battery deeply.

Following battery specifications are recommended:

Interface Parameter	Min.	Max.	915 Type A Nominal	915 Type C24 Nominal
Nominal Input Voltage			12 V	28 V
Internal resistance		Maximum 10 mΩ at -18 °C (-0.4 °F)		
Cold Cranking Ampere	350 A at -18 °C (-0.4 °F) (SAE J537)			
Capacity	16 Ah			

The usage of a battery with lower capacity may have a negative impact on the starting behavior of the engine. Additional electrical loads, which are in some cases required by law, may affect the battery performance during the starting process, (e.g. ACL (Anti Collision Light), Navigation Light, Avionics).

BRP-Rotax INSTALLATION MANUAL

CONTROL ELEMENTS

START POWER CONTROL	
Parameter	Value
Contact type	Momentary (must not be active after engine start)
Nominal voltage	28 V DC
Nominal current	20 A

BATTERY BACKUP CONTROL	
Parameter	Value
Contact type	Toggle (must not be active during normal operation)
Nominal voltage	28 V DC
Nominal current	20 A

915 i TYPE C24

The 28 V output of the AC-DC Converter is able to supply a maximum current of 27.9 A. If this current flow is exceeded, the 28 V output is switched off because an overload has been detected. The so-called hiccup mode now performs a cyclic activation of the output and queries the elimination of the overload. This is done in intervals of about three seconds.

If an accumulator is connected to the 28 V output and its charge state is very low, it can happen that the charge current exceeds the 27.9 A mentioned above. A switch-off of the 28 V output is the consequence and an overload is permanently detected by the hiccup mode. Charging the accumulator is therefore not possible.

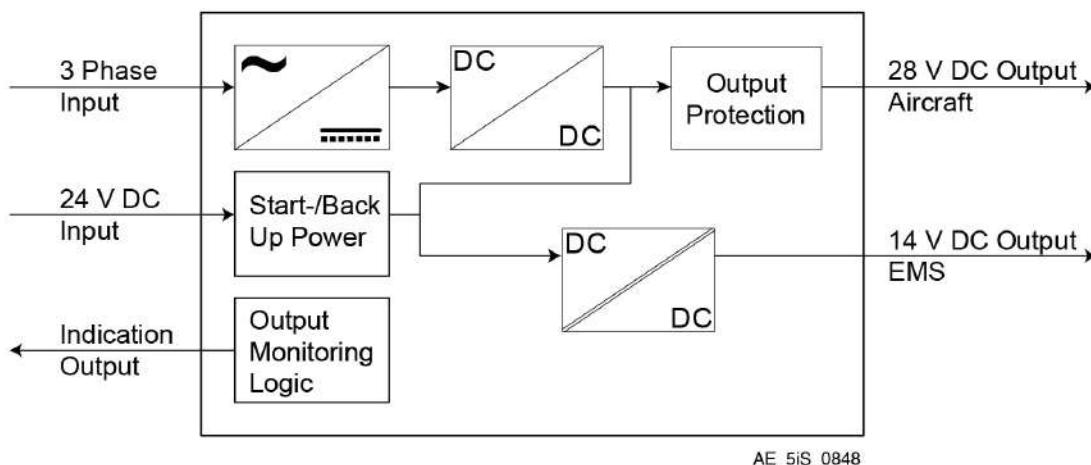
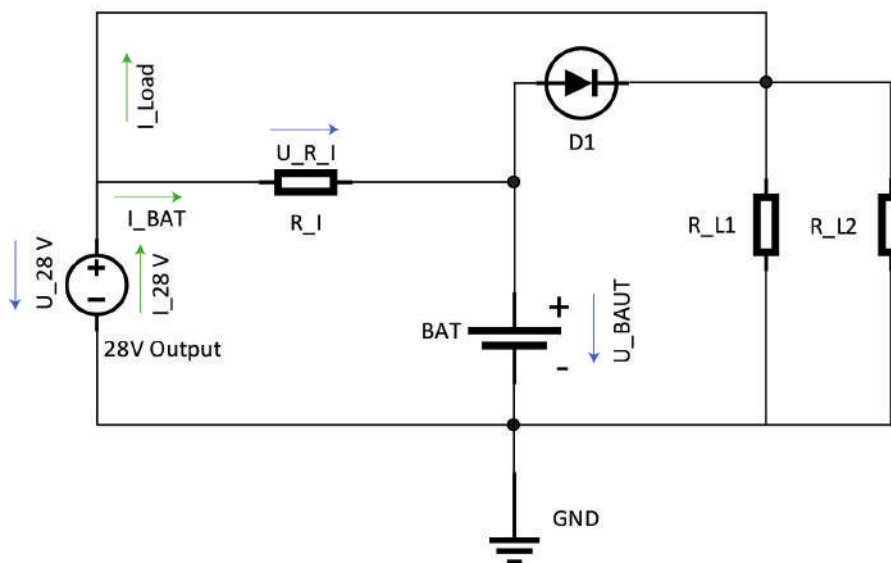

Figure 3.19: Schematic AC-DC Converter

BRP-Rotax INSTALLATION MANUAL

Concept for limiting the charging current:

In order to limit the charging current, a series resistor can be used. In following Figure this resistor is called R_I . R_{L1} and R_{L2} are symbolically shown as load (L= Load) of the 28 V output and define the current flow I_{Load} .



AE_5IS_0849

Figure 3.20: Simple Charging Circuit

Formula 1

The voltage drop U_{R_I} is the difference of $U_{28 V}$ and U_{BAT} :

$$U_{R_I} = U_{28 V} - U_{BAT}$$

Formula 2

The current flow I_{BAT} can be calculated as follows:

$$I_{BAT} = \frac{U_{R_I}}{R_I}$$

Example 1 – Calculate series resistance

$U_{28 V} = 28.9 V$, $U_{BAT} = 20 V$, $I_{BAT} = 10 A$

The accumulator is discharged, and the State of Charge is 0%. For U_{BAT} in this case 20 V is assumed. The AC-DC converter supplies a voltage of 28.9 V. The maximum charge current is set to 10 A. U_{R_I} is therefore 8.9 V.

Formula 2 is transformed to R_I and from the division U_{R_I} to I_{BAT} a resistance value of 0.89Ω results.

The following figures show the relationship between resistance R_I and current I_{BAT} and the resulting power dissipation once for $U_{R_I} = 9 V$ and $U_{R_I} = 5 V$.

BRP-Rotax INSTALLATION MANUAL

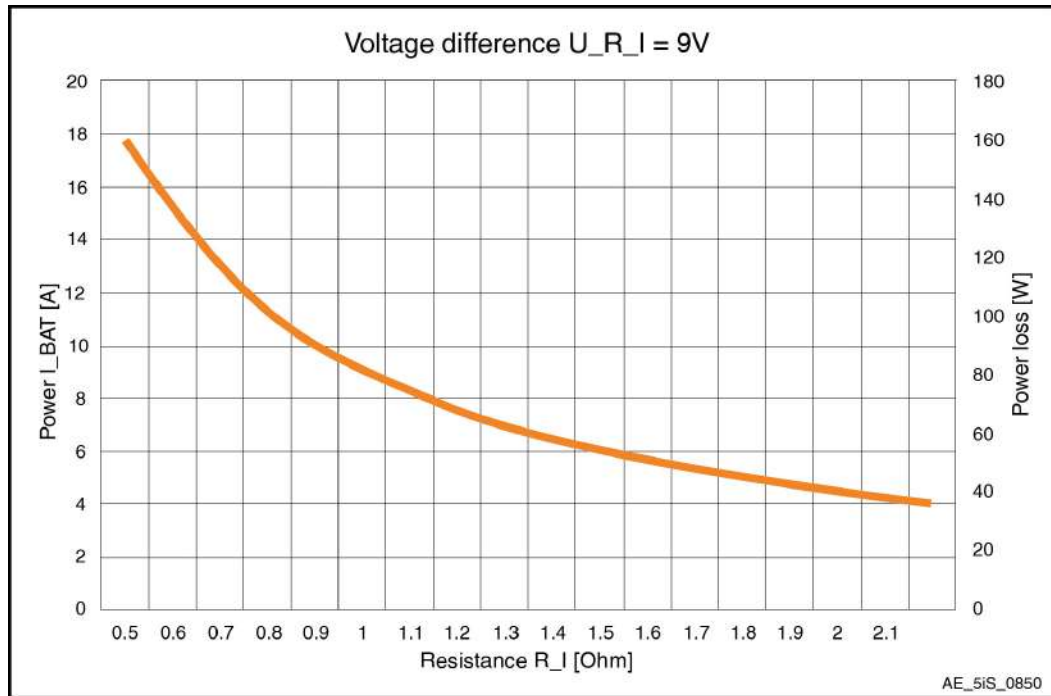

Figure 3.21: $U_{R_I} = 9V$

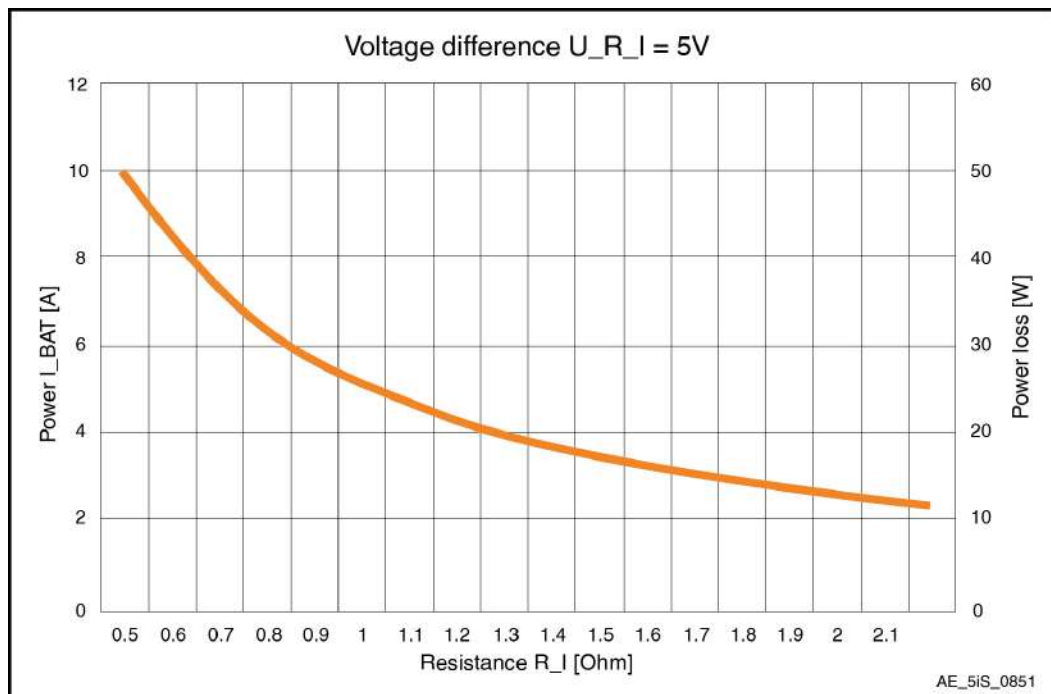

Figure 3.22: $U_{R_I} = 5V$

BRP-Rotax

INSTALLATION MANUAL

Formula 3 The sum of the currents from I_BAT and I_Load results in I_28 V and must not exceed 27.9 A:

$$I_{\text{BAT}} + I_{\text{Lad}} < 27.9 \text{ A}$$

Formula 4 $I_{\text{BAT}} + I_{\text{Load}} = I_{\text{28 V}}$

If I_28 V is greater than 27.9 A, the 28 V output is switched off, as already mentioned at the beginning. Therefore, the condition from formula 3 must always be fulfilled. The expected load current I_BAT and the load current I_Load must be calculated by the installer.

Formula 5 Special attention must be paid to the dimensioning of the resistor with regard to the power dissipation:

$$P = I_2^2 * R$$

Once the battery is charged, the current flow is reduced to a minimum and thus also the power loss, which is converted into heat.

Example 2 – Calculate power dissipation:

$I = 10 \text{ A}$, $R_I = 0.89 \Omega$

From formula 5, the worst-case power dissipation is 89 Watts.

To supply the aircraft with voltage when the AC-DC converter is not active, the accumulator is used. Therefore, it must also be connected to the loads R_L1 and R_L2. Without the diode D1, the resistor R_I would be bypassed, and a current limitation would no longer exist. The choice and dimensioning of the diode must be adapted to the individual requirements of the aircraft. Parameters like voltage drop, current and cooling must be considered.

Summary:

By using a series resistor R_I the charging current to the accumulator can be limited.

Feeding the aircraft via the accumulator gate is made possible by a diode which prevents bridging of the series resistor R_I.

Special attention must be paid to the component dimensioning in order to achieve the desired reliability at these relatively high currents.

BRP-Rotax INSTALLATION MANUAL

VALIDATION OF INSTALLATION

General

The validation procedures described in this chapter do not claim to be complete. The correct execution and compliance with all given system limitations and interface descriptions as well as with standards and norms given by authorities must be proven by the aircraft manufacturer.

External Power Supply

If an engine is installed in a specific aircraft type for the first time, it is required to measure the voltage on three positions:

- Battery Voltage (separate Voltmeter)
- Voltage on Electric Starter (separate Voltmeter)
- ECU Bus Voltage (displayed in BUDS Aircraft diagnostic tool)

Depending on the geographical location where the engine should be used, this measurement must be done at the lowest reachable ambient temperature. In case the measured voltages drop below 9 V especially during engine start, the installation is insufficient. In this case specification of the external power source, the execution of the wiring as well as the total consumption of all electrical loads needs to be checked.

Separation of EMS and Airframe circuit

915 i TYPE A

Test to ensure there is no continuity between Fusebox Regulator A and Fusebox Regulator B in static condition (Fusebox is not supplied with power by an external power source). To determine the ECU BUS voltage at the transient moment of the engine start an oscilloscope must be used and also the total consumption of all electrical loads needs to be checked.

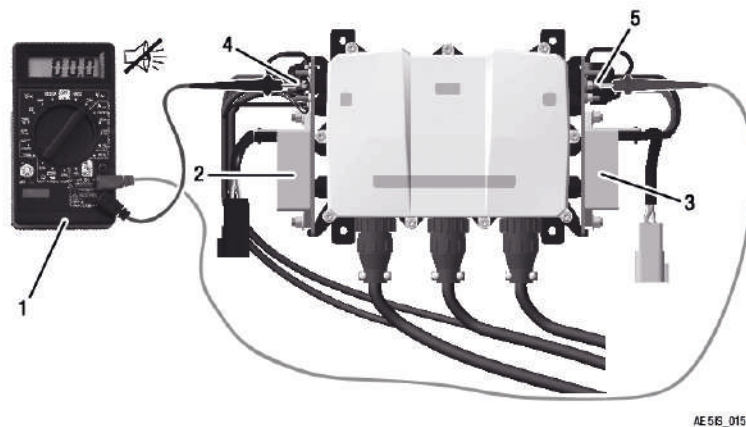

Figure 3.23: Validation of EMS and Airframe Circuit separation

- | | | | |
|---|--|---|---|
| 1 | Multimeter | 2 | Rectifier regulator A (black connector) |
| 3 | Rectifier regulator B (grey connector) | 4 | Ground connections regulator A |
| 5 | Ground connections regulator B | | |

In case of continuity the installation is not sufficient and the wiring concept needs to be revised.

BRP-Rotax INSTALLATION MANUAL

Separation of EMS and Airframe circuit

915 i TYPE C24

Test to ensure there is no continuity between Fusebox Regulator A and Fusebox Regulator B in static condition (Fusebox is not supplied with power by an external power source). To determine the ECU BUS voltage at the transient moment of the engine start an oscilloscope must be used and also the total consumption of all electrical loads needs to be checked.

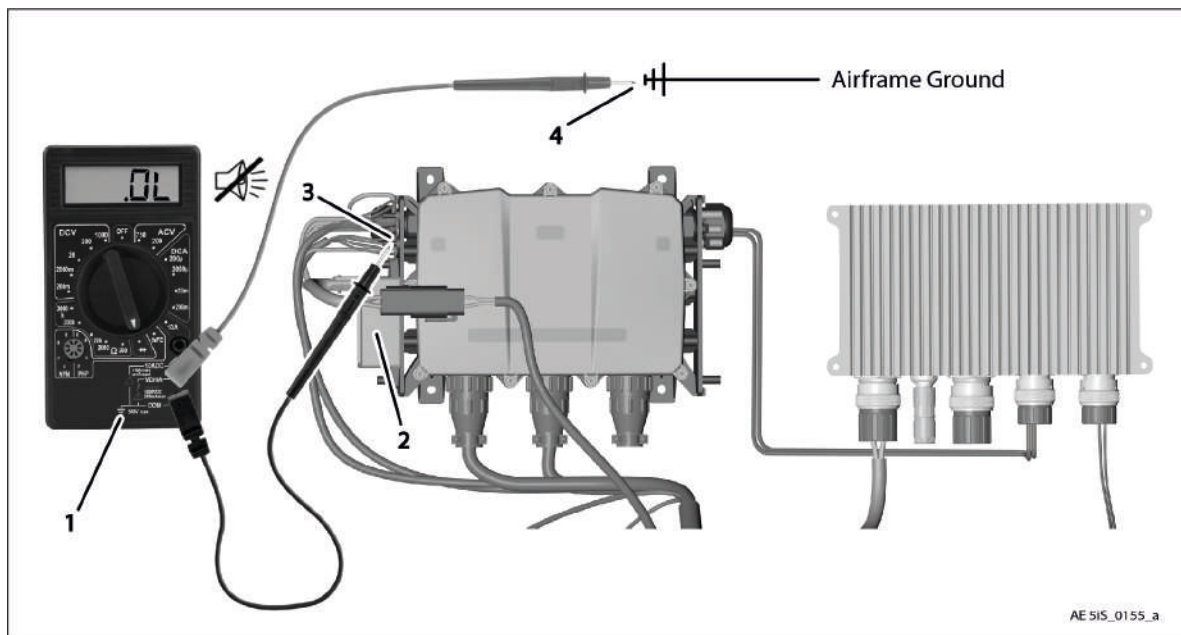

Figure 3.24: Validation of EMS and Airframe Circuit separation

- | | | | |
|---|--------------------------------|---|---|
| 1 | Multimeter | 2 | Rectifier regulator A (black connector) |
| 3 | Ground connections regulator A | 4 | Airframe ground |

In case of continuity the installation is not sufficient and the wiring concept needs to be revised.

BRP-Rotax INSTALLATION MANUAL

EMS and Airframe circuit test for AC-DC Converter

915 i TYPE C24

Test to ensure there is no warning or caution lamp indication between AC-DC Converter and any known airframe (aircraft) ground when EMS system is powered (EMS system is powered on, engine need to run for this test - please follow the procedures mentioned in the current Operators Manual. The engine must run on an engine speed at 3000 1/min for at least 2 minutes.)

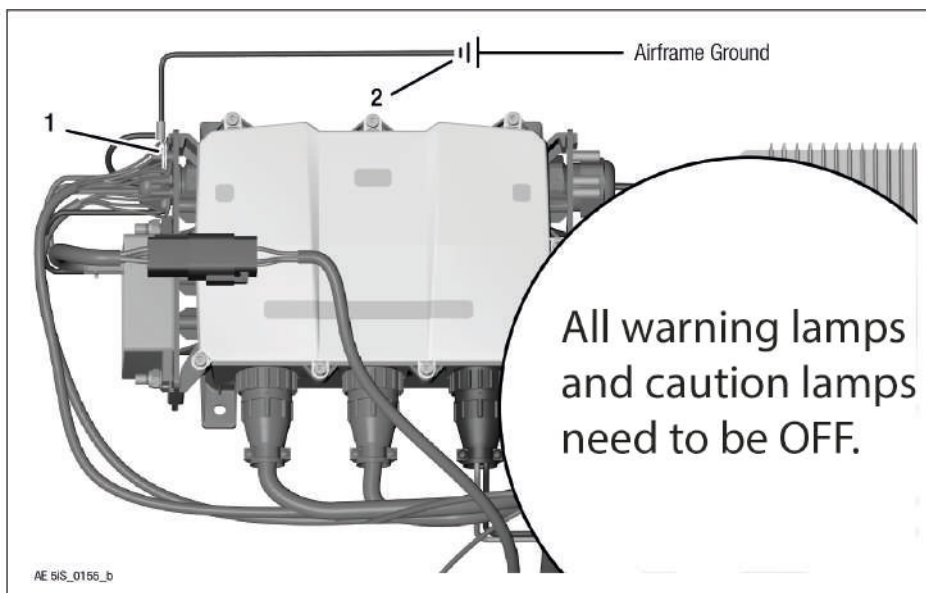

Figure 3.25: Airframe circuit test for AC-DC Converter

1 Ground connections regulator A 2 Airframe ground

- Connect a cable between ground connections regulator A to any airframe ground point
- Check all safety regulations, because EMS system now gets powered ON and the engine will be started
- Run the engine for 2 minutes at 3000 1/min (follow the procedures mentioned in the current Operators Manual).

Check for warn- ing and/or cau- tion lamp indication

915 i TYPE C24

Check that warning lamps and caution lamps stay OFF at an engine speed of 3000 1/min and for 2 minutes engine run. If not, there is a connection between EMS ground and airframe ground which need to be detected and removed before engine and aircraft can be released.

BRP-Rotax
INSTALLATION MANUAL

Chapter: 61-00-00
PROPELLER DRIVE

TOPICS IN THIS CHAPTER

System description3
 System limitations3

Interface description4
 Interface overview4
 Mechanical interfaces6
 Hydraulic governor for constant speed propeller8

BRP-Rotax
INSTALLATION MANUAL

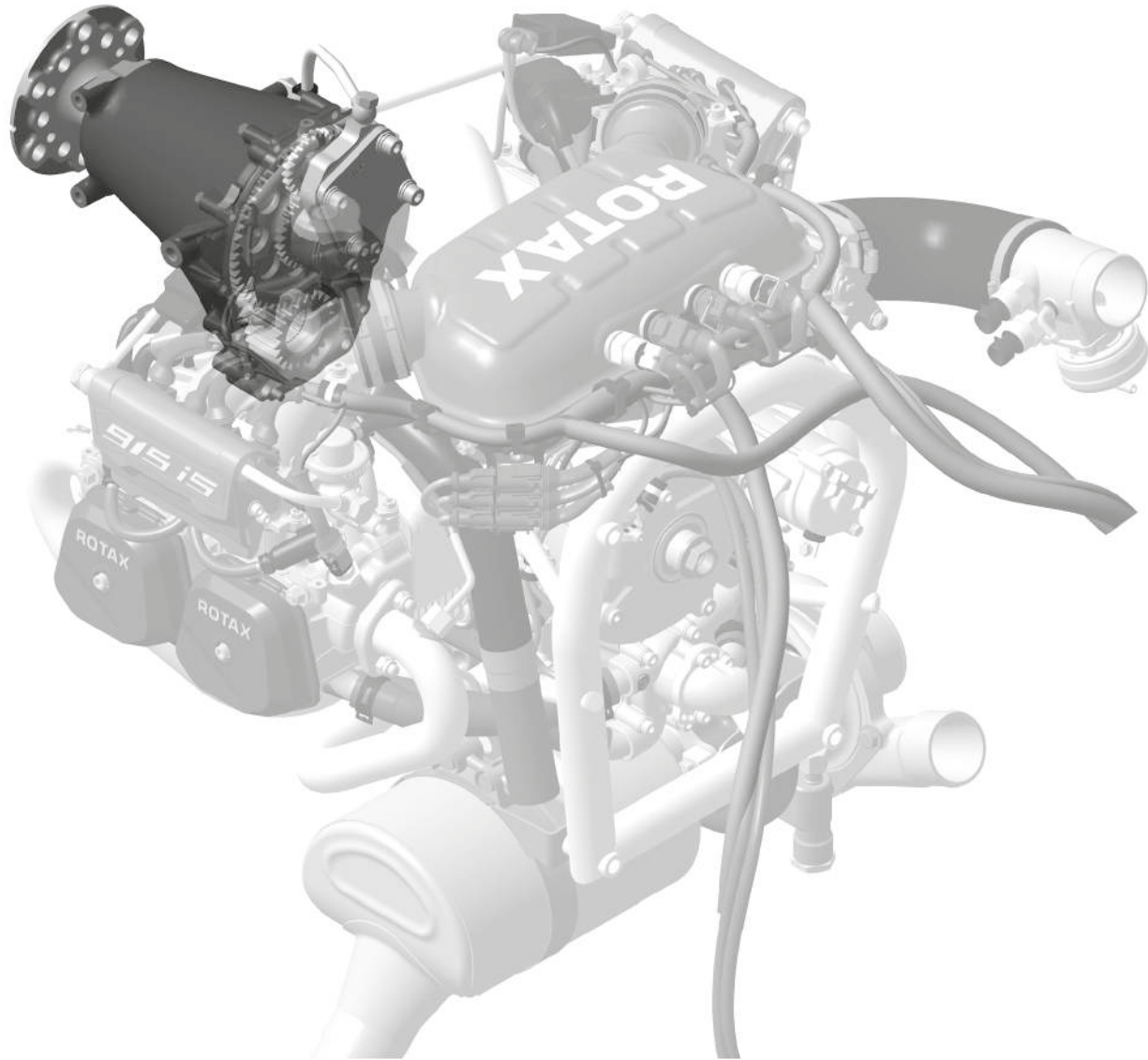

AE 5iS_0156

Figure 4.1: Propeller drive – TYPICAL

BRP-Rotax INSTALLATION MANUAL

SYSTEM DESCRIPTION

For a detailed System description refer to the latest issue of the Operators Manual (OM).

SYSTEM LIMITATIONS

Operating limits Refer to latest issue of the Operators Manual (OM).

Moment of inertia

System Limit	Min.	Max.
Moment of inertia on propeller	1500 kg cm ² (3.559 lb ft ²)	7500 kg cm ² (17.798 lb ft ²).

Out of balance

Dynamic balancing of the propeller as specified by the propeller manufacturer must be carried out.

Propeller shaft

System Limit	Min.	Max.
Extension of the propeller shaft	-	Maximum 70 mm (2.75 in.)

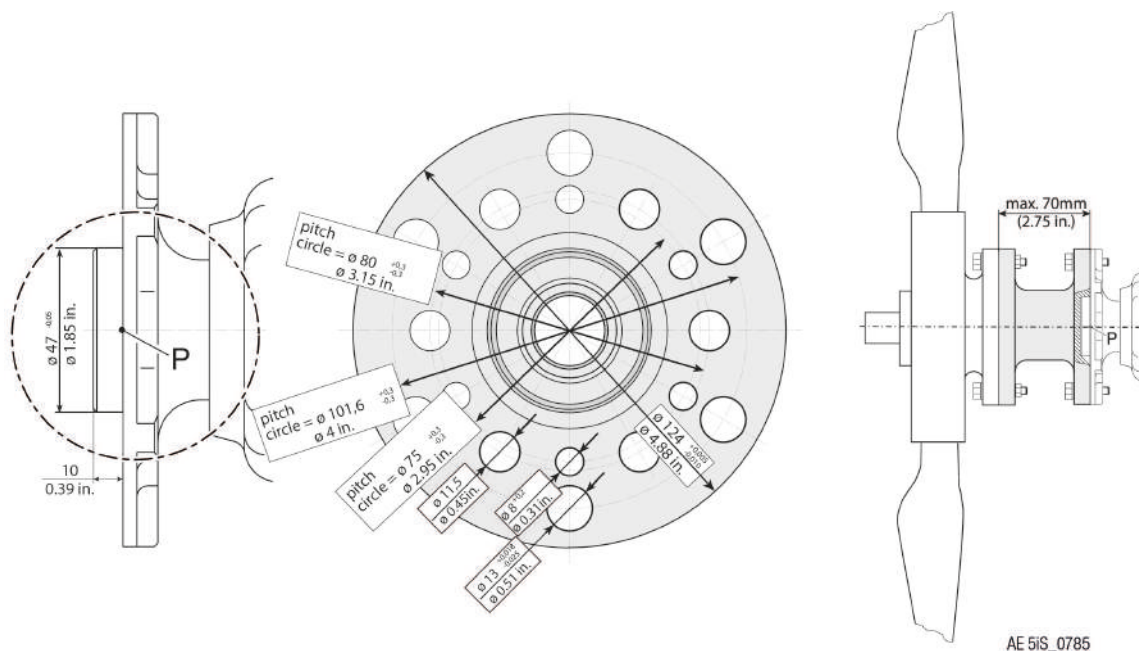

Figure 4.2

Hydraulic governor flange/drive/oil supply

System Limit	Min.	Max.
Power consumption of governor	-	600 W
Operating pressure of governor	-	10 bar (145 psi) peak pressure: 30 bar (435 psi)

BRP-Rotax
INSTALLATION MANUAL

INTERFACE DESCRIPTION

INTERFACE OVERVIEW

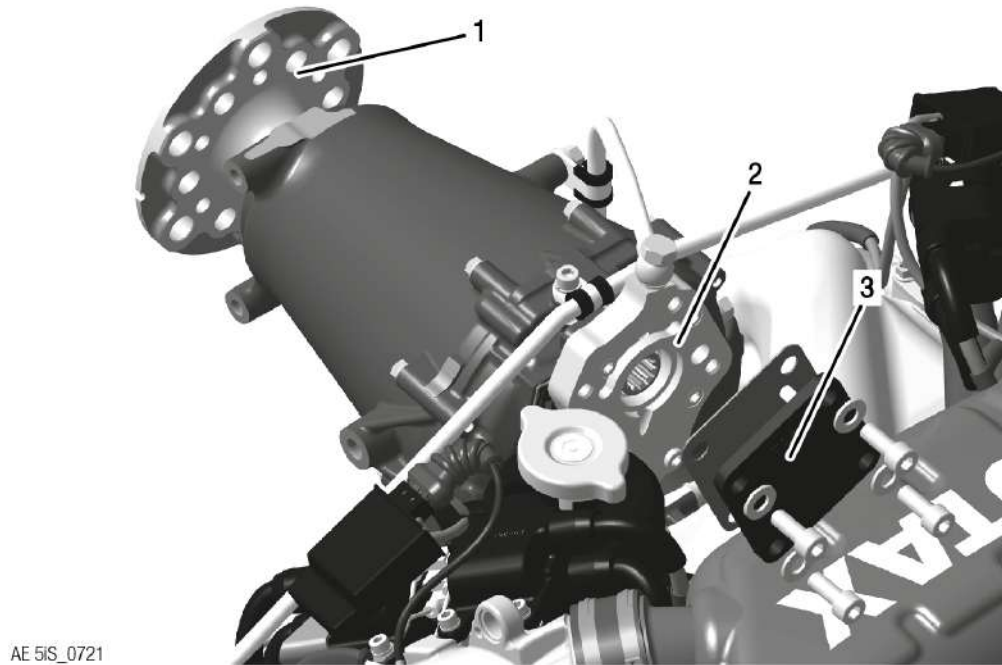

Figure 4.3: Interface (configuration 3)

- 1 Propeller shaft (mechanical. Interface) 2 Governor flange (hydraulic. Interface)
3 Cover plate

NOTE

The cover used for delivery needs to be removed before engine operation. The cover may not be used in operational condition.

BRP-Rotax
INSTALLATION MANUAL

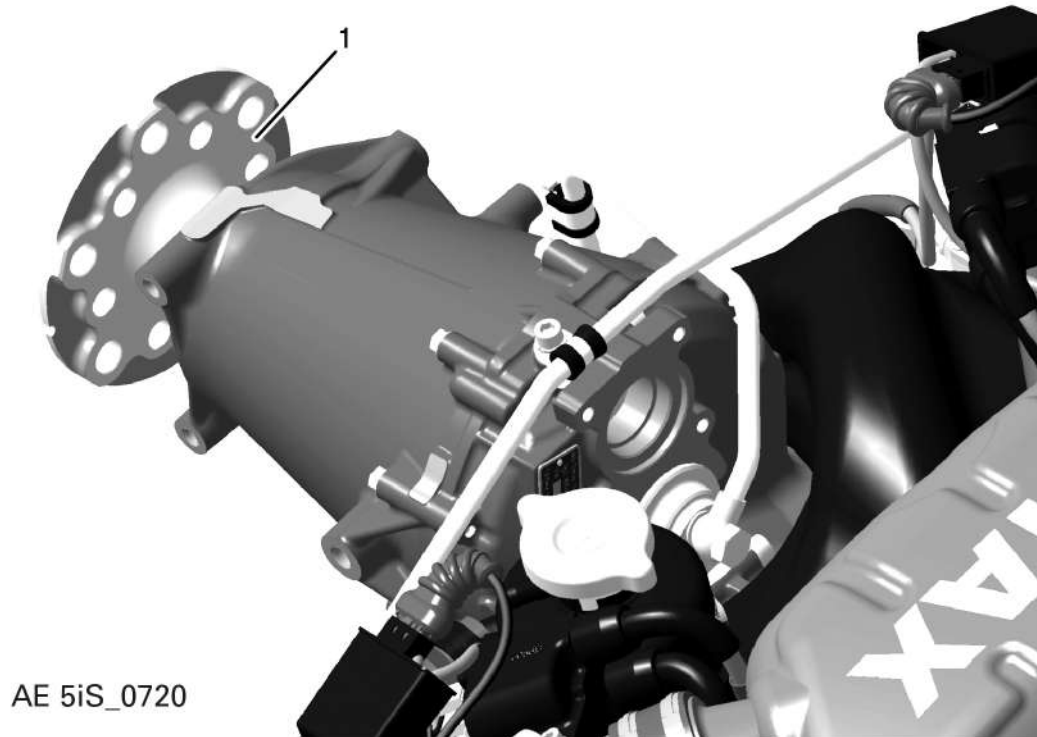

Figure 4.4: Interface (configuration 2)

1 *Propeller shaft (mechanical. Interface)*

BRP-Rotax INSTALLATION MANUAL

MECHANICAL INTERFACES

Propeller shaft flange

The propeller in tractor or pusher arrangement must be fitted on the propeller flange in accordance with applicable regulations. As required utilize one of three possible pitch circle diameters (P.C.D.) on the flange.

NOTICE

Modification of the propeller shaft is not permitted.

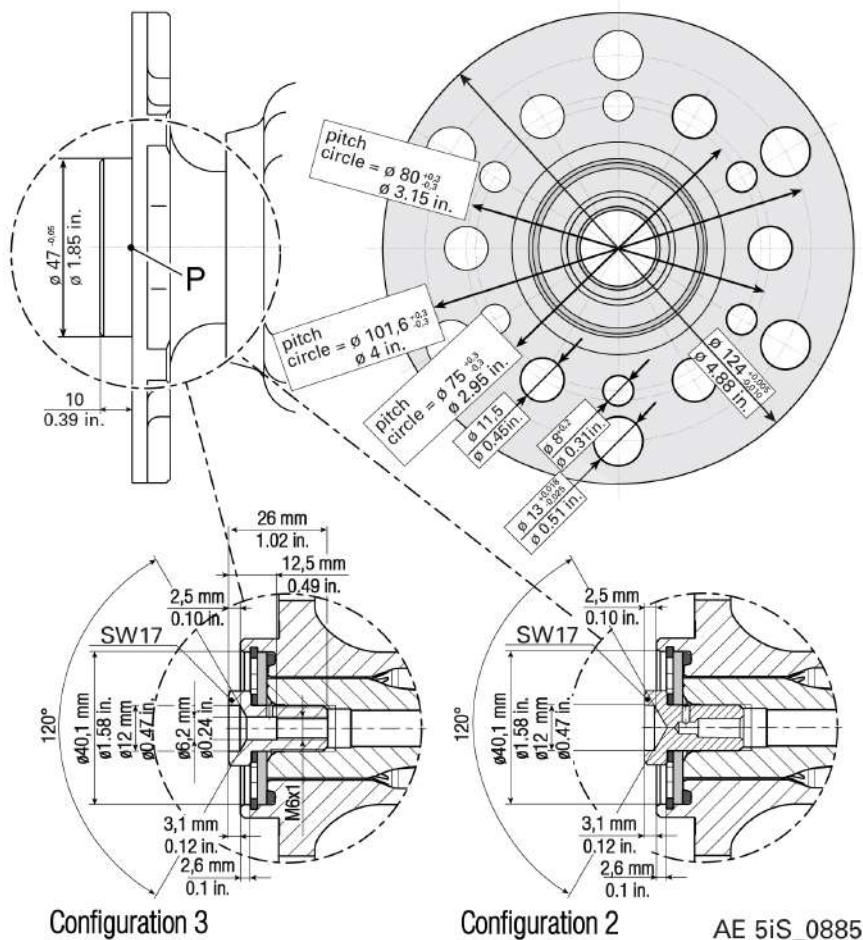

Figure 4.5: Propeller shaft flange

NOTICE

Propeller hub has to be centered on diameter 47 mm (1.85 in.).

BRP-Rotax INSTALLATION MANUAL

Interface Parameter	Value
Pitch circle diameter 75 mm (2.95 in.)	6x through holes 8 mm (0.31 in.)
Pitch circle diameter 80 mm (3.15 in.)	6x through holes 11.5 mm (0.45 in.)
Pitch circle diameter 101.6 mm (4 in.)	6x through holes 13mm (0.51 in.)
Hub diameter	47 mm (1.85 in.)
Gear transmission	$i=2.54$. Propeller shaft turns with 0.395 times engine speed.

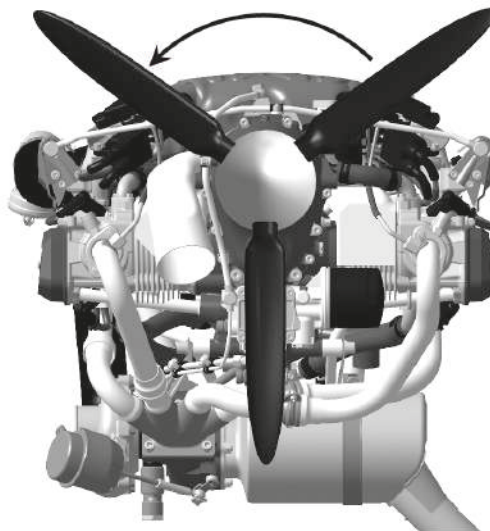

AE 5IS_0143a

Figure 4.6: Direction of rotation

BRP-Rotax
INSTALLATION MANUAL

HYDRAULIC GOVERNOR FOR CONSTANT SPEED PROPELLER

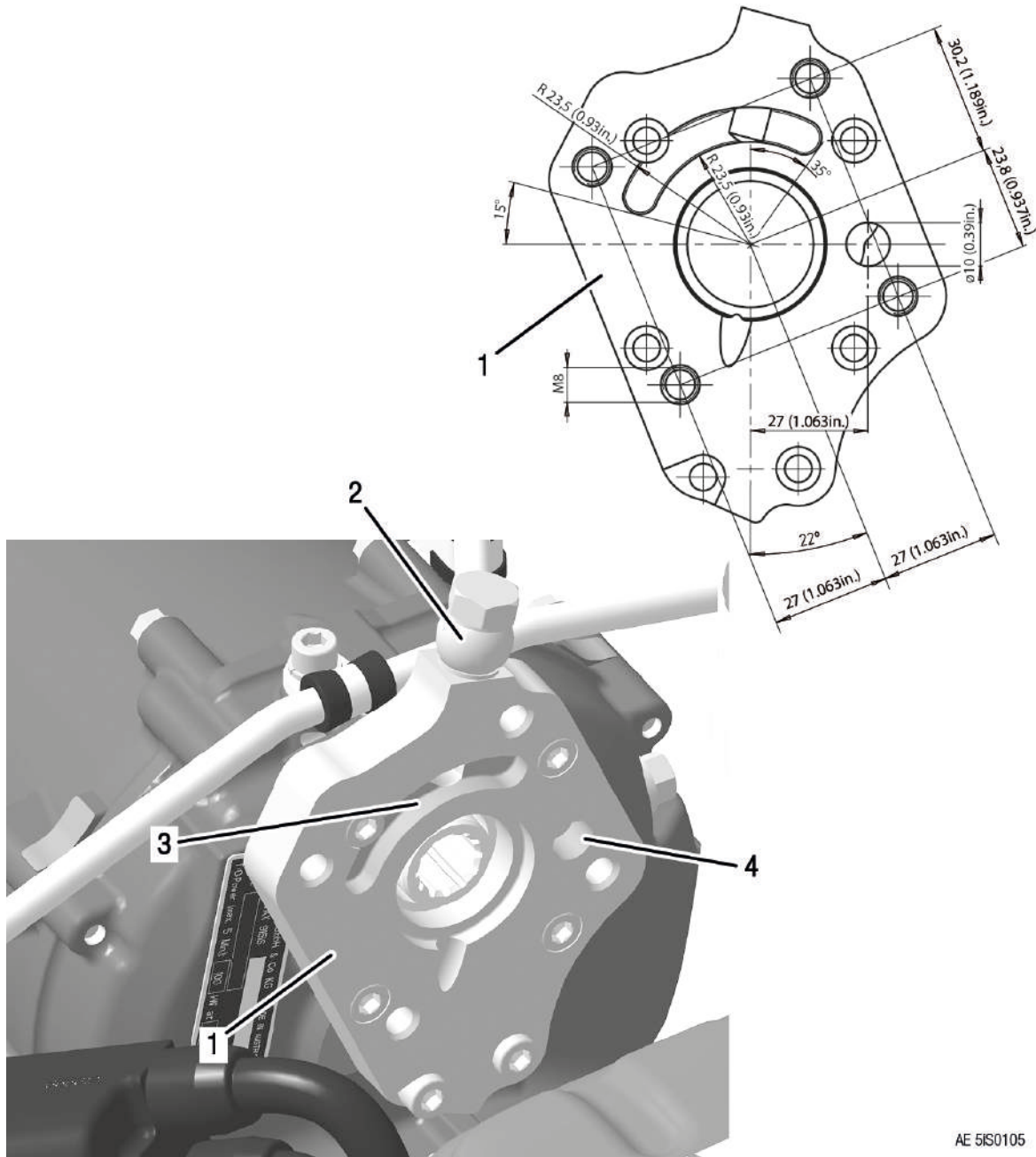

Figure 4.7: Governor flange (configuration 3 only)

- | | |
|-------------------|---------------------------|
| 1 Governor flange | 2 Pressure oil line assy. |
| 3 Oil inlet | 4 Oil outlet |

BRP-Rotax INSTALLATION MANUAL

Drive

Drive via propeller gearbox.

Position of the propeller connection on the governor flange:

x-axis [mm/in]	y-axis [mm/in]	z-axis [mm/in]
-206.3 (-8.12)	0	51.5 (2.03)

Connection

NOTICE
Obey the manufacturers instructions!

Technical Data

Gear ratio from crankshaft to hydraulic governor is 1.932, i.e. the propeller governor runs at 0.759 times engine speed.

Mounting pad	AND20010
Thread size	M8
Thread length	max. 14 mm (0.55 in)
Toothing	Internal spline 20/40 SMS 1834 NA 14x1,27x30x12
Power input	max. 600 W
Operating pressure	max. 30 bar (435 psi)

BRP-Rotax
INSTALLATION MANUAL

INTENTIONALLY LEFT
BLANK

BRP-Rotax
INSTALLATION MANUAL

Chapter: 72-00-00
ENGINE

TOPICS IN THIS CHAPTER

System description **3**
 System limitations 6

Interface description **9**
 Interface overview 9
 Mechanical interfaces 9

Installation notes **13**
 Engine suspension 13

BRP-Rotax
INSTALLATION MANUAL

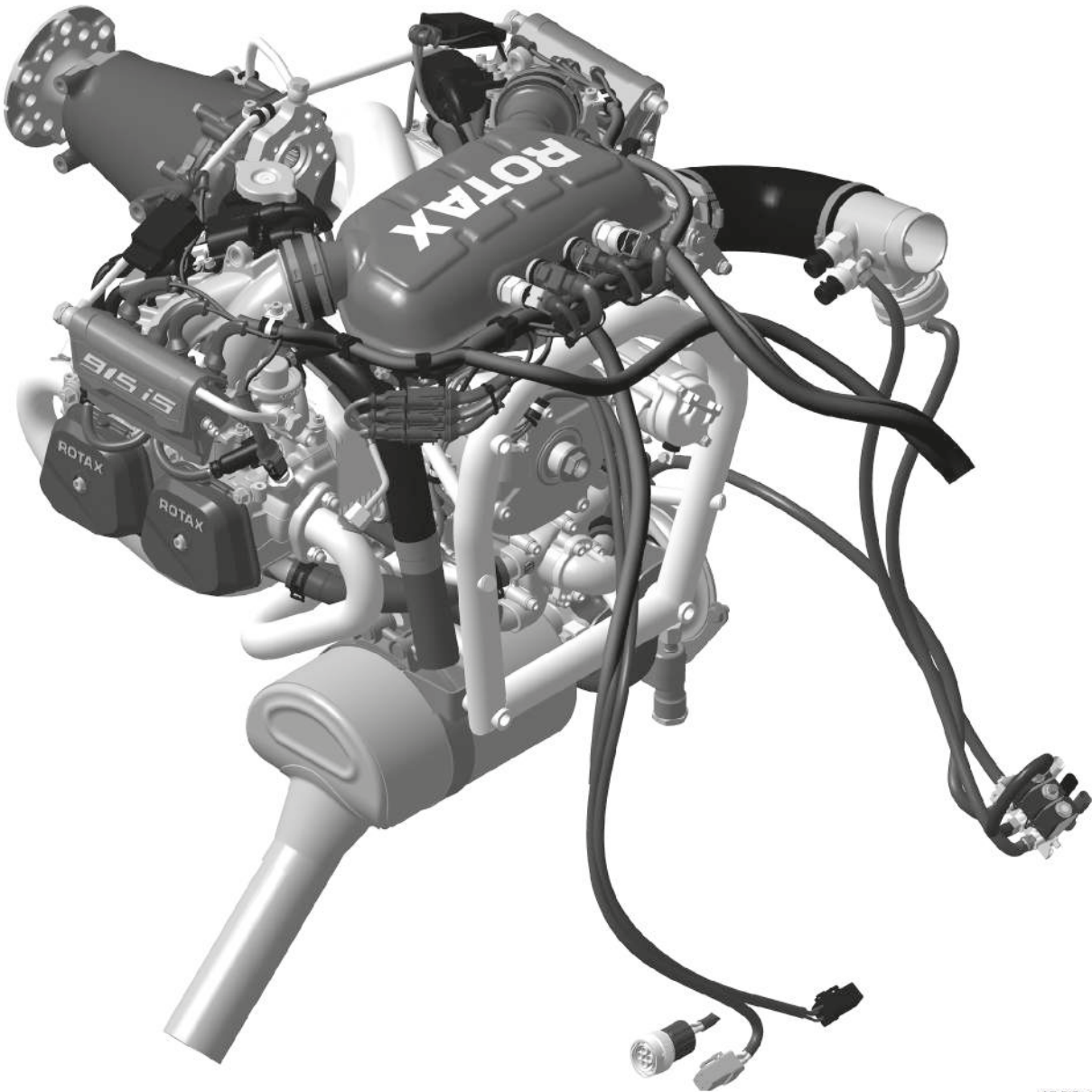

AE 515_0158

Figure 5.1: Engine – TYPICAL

BRP-Rotax INSTALLATION MANUAL

SYSTEM DESCRIPTION

For a detailed System description refer to the latest issue of the Operators Manual.

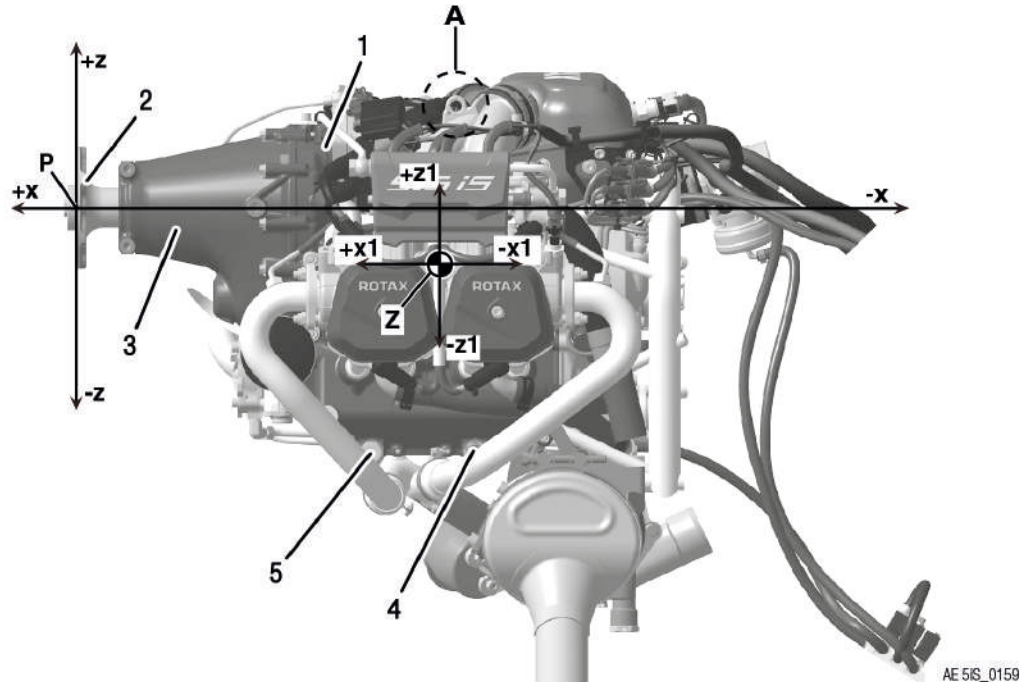
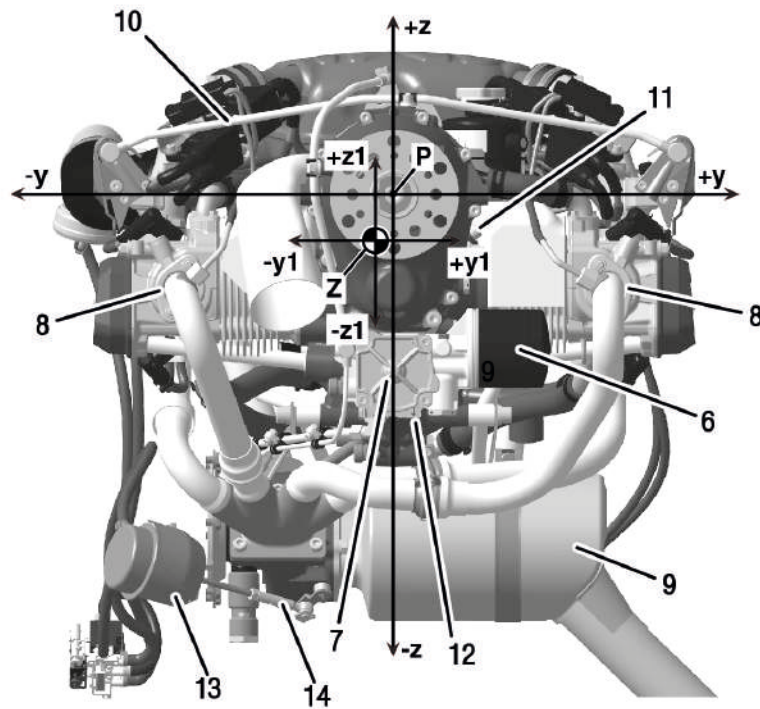

Figure 5.2: Engine side view

- | | | | |
|---|----------------------------|---|--|
| 1 | Engine number | 2 | Propeller flange |
| 3 | Propeller gearbox | 4 | Connection for return line, both sides mandatory |
| 5 | Connection for return line | A | Attachment points (for engine lifting) |
| Z | Center of gravity (Z) | P | Reference coordinate system (X, Y, Z) |

BRP-Rotax INSTALLATION MANUAL



AE 5IS_0161

Figure 5.3: Engine Front view

- | | |
|---|--------------------------------------|
| 6 Oil filter | 7 Oil pump |
| 8 Exhaust flange | 9 Muffler assy. |
| 10 Fuel line assy. | 11 Crankshaft locking screw position |
| 12 Connection for Turbo oil line return | 13 Wastegate regulator assy. |
| 14 Wastegate rod end | |

BRP-Rotax INSTALLATION MANUAL

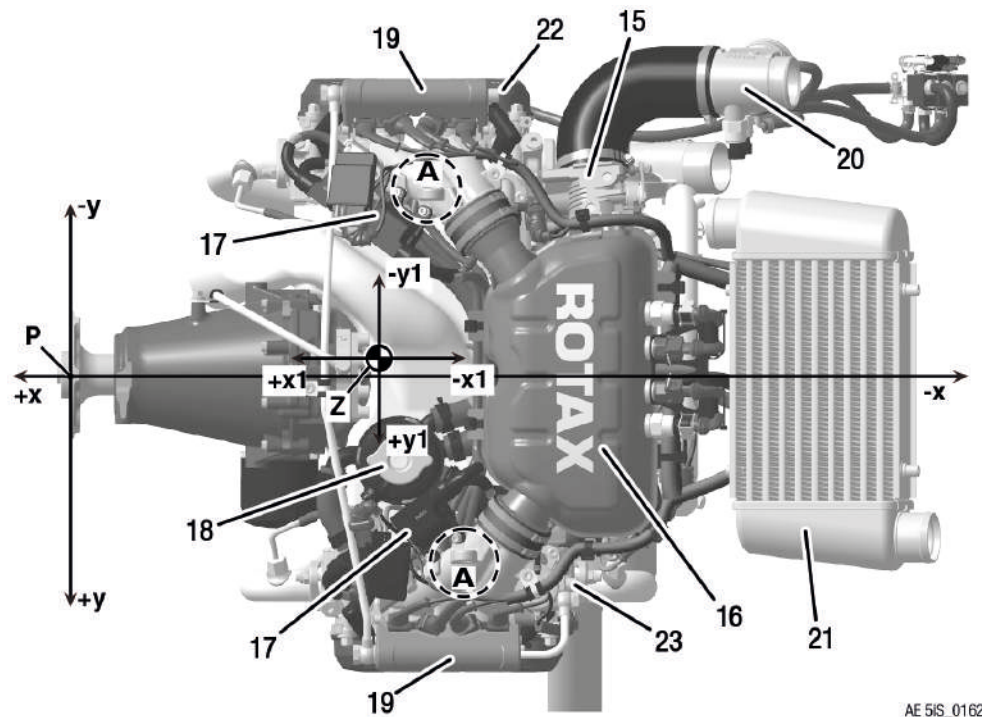

AE 5iS_0162

Figure 5.4: Top view

- | | | | |
|----|---------------------------------|----|--|
| 15 | Throttle valve support assy. | 16 | Airbox |
| 17 | Dual ignition coils | 18 | Expansion tank assy. |
| 19 | Fuel rail (right, left) | 20 | POP OFF valve |
| 21 | Inter cooler | 22 | Connection for fuel feed line |
| 23 | Connection for fuel return line | A | Attachment points (for engine lifting) |

BRP-Rotax INSTALLATION MANUAL

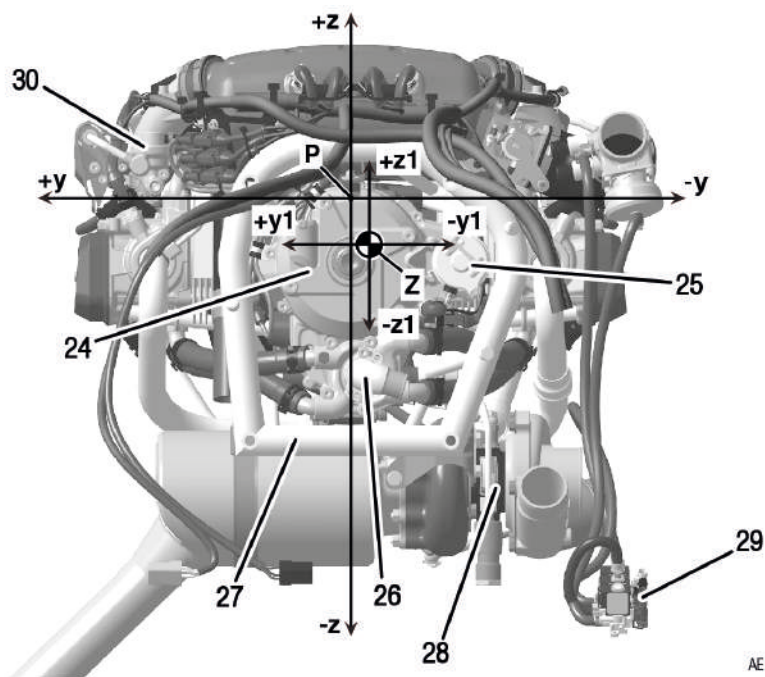

AE 5IS_0163

Figure 5.5: Rear view

- | | |
|----------------------------|---|
| 24 Ignition housing | 25 Electric starter |
| 26 Water pump housing | 27 Engine suspension frame (ring mount) |
| 28 Turbocharger assy. | 29 Pressure control valve (PCV) |
| 30 Fuel pressure regulator | |

SYSTEM LIMITATIONS

Operating limits Refer to latest issue of the Operators Manual (OM).

Installation position The oil system, fuel system and the cooling system are unsuitable for upside-down / inverted installation of the engine.

System Limit	Min.	Max.
Static roll angle β		40°

The oil level should be in the upper half (between the “50%” and the “Max.” mark) and should never fall below the “Min.” mark. For the oil level measuring procedure refer to the latest version of the respective Operators Manual (OM).

BRP-Rotax INSTALLATION MANUAL

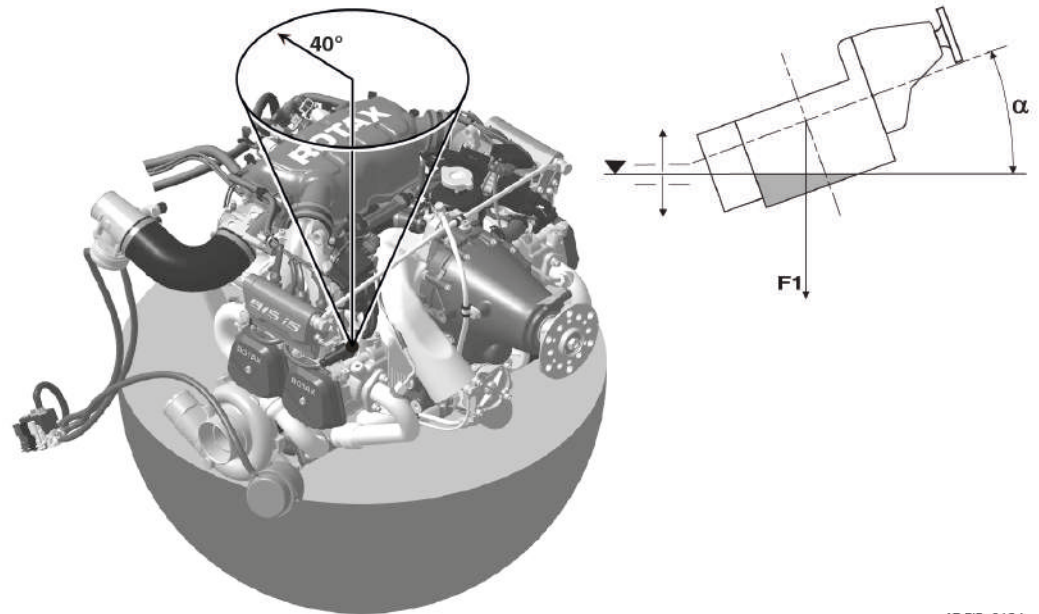

AE 5IS_0164

Figure 5.6: Bank angle

Angle/force	Description
α	Bank or rotation
F1	Gravity

Attachment points

For mounting the engine on the engine suspension, R2, R3, L3 and L2 of attachment points must be used. Attachment bolts/screws must not protrude into engine components.

BRP-Rotax INSTALLATION MANUAL

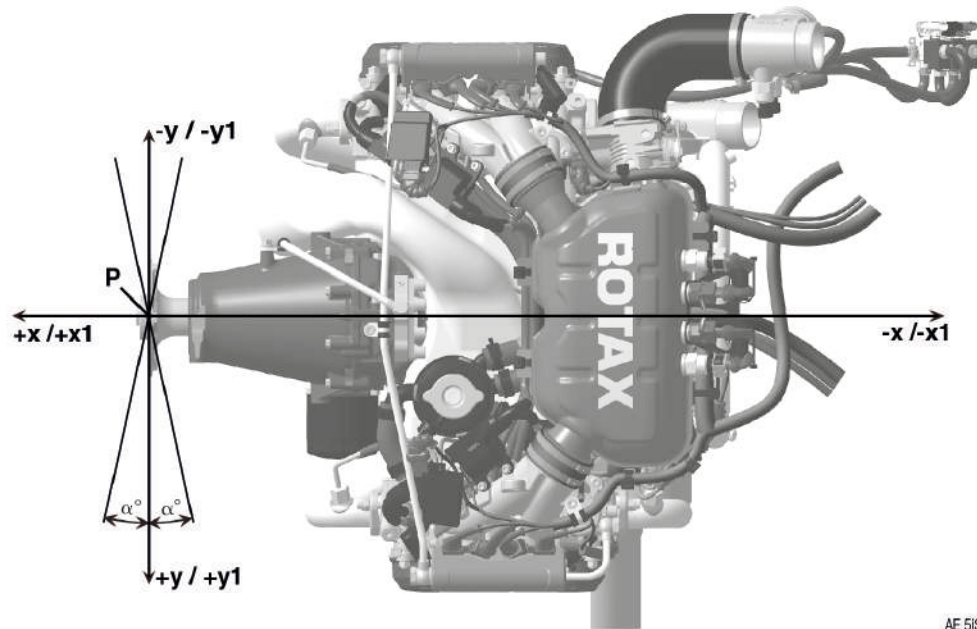

AE 5iS_0165

Figure 5.7: Propeller and vertical axis

Propeller axis

The y1-axis must be perpendicular to the longitudinal axis of the aircraft.

System Limit	Min.	Max.
Permissible deviation from perpendicular (α)	- 10°	+ 10°

BRP-Rotax INSTALLATION MANUAL

INTERFACE DESCRIPTION

INTERFACE OVERVIEW

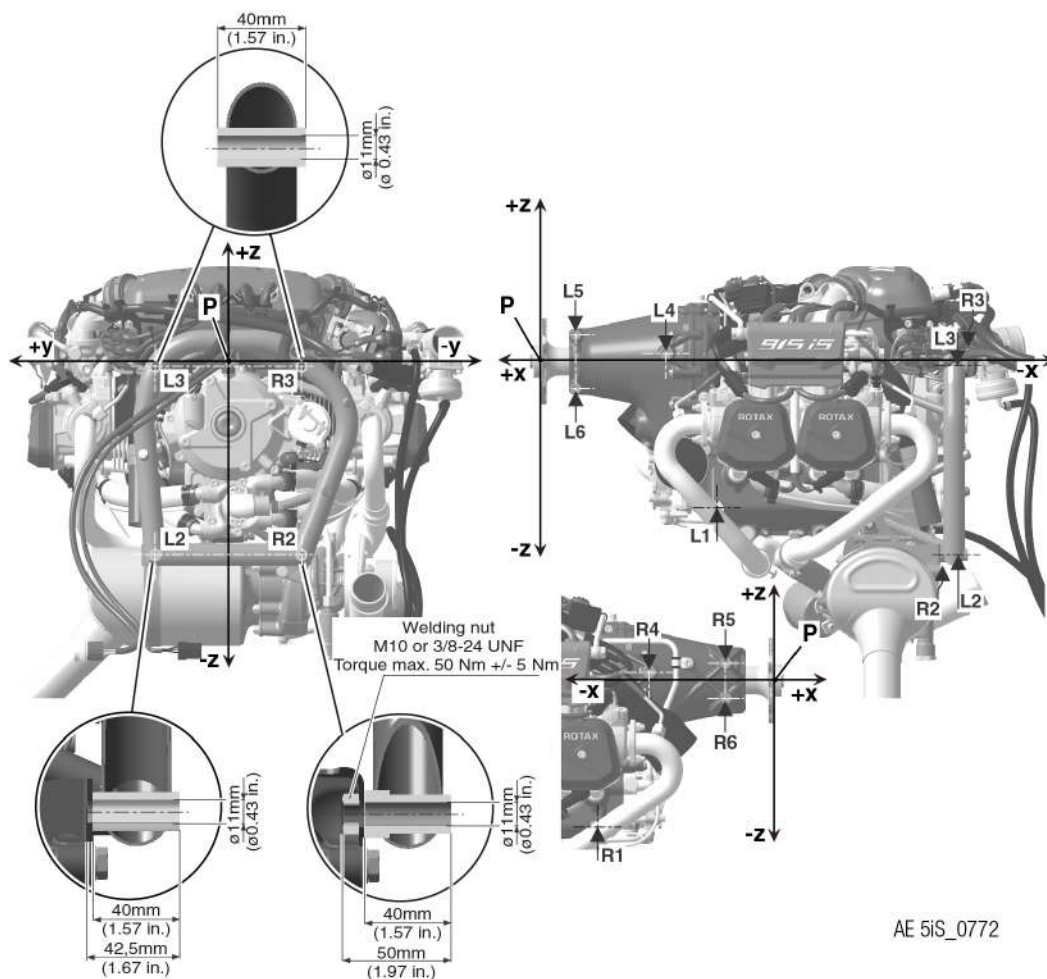

AE 5iS_0772

Figure 5.8: Attachment points

MECHANICAL INTERFACES

Attachment points

Interface Parameter	Value			
	L1	R1	L2	R2
x-axis (in)	- 253.5 mm (9.98 in.)		- 615 mm (24.21 in.)	
y-axis (in)	- 71 mm (-2.8 in.)		105 mm (4.13 in.)	- 105 mm (-4.13 in.)
z-axis (in)	- 211 mm (-8.31 in.)		- 277 mm (-10.91 in.)	

BRP-Rotax INSTALLATION MANUAL

Interface Parameter	Value			
Attachment points	L1	R1	L2	R2
Thread	M10		—	
Max. usable Thread length	25 mm (0.98 in.)			

Interface Parameter	Value			
Attachment points	L3	R3	L4	R4
x-axis (in)	- 615 mm (24.21 in.)		- 181 mm (7.13 in.)	
y-axis (in)	105 mm (4.13 in.)	-105 mm (-4.13 in.)	90 mm (3.54 in.)	-90 mm (-3.54 in.)
z-axis (in)	-7 mm (-0.28 in.)		12.2 mm (0.48 in.)	
Thread	—		M10	
Max. usable Thread length			16 mm (0.63 in.)	

Interface Parameter	Value			
Attachment points	L5	R5	L6	R6
x-axis (in)	- 51 mm (1.97 in.)	- 71 mm (2.79 in.)	- 51 mm (1.97 in.)	- 71 mm (2.79 in.)
y-axis (in)	48 mm (1.89 in.)	-64.5 mm (-2.54 in.)	48 mm (1.89 in.)	-64.5 mm (-2.54 in.)
z-axis (in)	25.4 mm (1.00 in.)	39 mm (1.53 in.)	-25.4 mm (-1.00 in.)	-39 mm (-1.53 in.)
Thread	M8		M8	
Max. usable Thread length	20 mm (0.79 in.)		20 mm (0.79 in.)	

⚠ WARNING

Non-compliance can result in serious injuries or death!

The aircraft or fuselage manufacturer must design the engine suspension so that it can safely carry the maximum occurring operational loads without exceeding the max. allowable forces and bending moments on the engine housing and attachment points.
Tighten all engine suspension screws as specified by the aircraft manufacturer.

BRP-Rotax INSTALLATION MANUAL

Weight

Engine component	Weight
Base engine with gearbox:	74.23 kg (163.65 lb)
Governor drive add on weight version 3	0.60 kg (1.32 lb)
Cooling air baffle	0.38 kg (0.838 lb)
PCV	0.35 kg (0.771 lb)
Oil tank	1.50 kg (3.31 lb)
Intercooler	1.65 kg (3.65 lb)
ECU	1.13 kg (2.49 lb)
Fusebox 915 i A Series	2.02 kg (4.45 lb)
Fusebox 915 i C24 Series	1.64 kg (3.62 lb)
Ambient sensors	0.06 kg (0.132 lb)
Wiring harness 915 i A Series	2.50 kg (5.51 lb)
Wiring harness 915 i C24 Series	1.84 kg (4.06 lb)
Intermediate flange with overboost valve, air hose and clamps	0.78 kg (1.72 lb)
AC-DC Converter assy.	1.68 kg (3.70 lb)
Total 915 iSc 3 A Series with governor drive	85.2 kg (187.8 lb)
Total 915 iSc 3 C24 Series with governor drive	85.9 kg (189.4 lb)
Starter Relay	0.14 kg (0.308 lb)

Centre of gravity of engine

The position information of the center of gravity does only consider the engine itself. Parts without an specific installation position in relation to the reference coordinate system are not considered.

NOTE

All distances are given in relation to the reference coordinate system (P).

Axis	Center of gravity
X-axis	- 376 mm (14.80 in.)
Y-axis	-15.9 mm (-0.63 in.)
Z-axis	-115.9 mm (-4.56 in.)

BRP-Rotax
INSTALLATION MANUAL

Moments of inertia (relative to COG)

Axis	Moment of inertia
X-axis	$2.0020282 \cdot 10^6 \text{ kg} \cdot \text{mm}^2$
Y-axis	$2.5397901 \cdot 10^6 \text{ kg} \cdot \text{mm}^2$
Z-axis	$2.9713711 \cdot 10^6 \text{ kg} \cdot \text{mm}^2$

BRP-Rotax INSTALLATION MANUAL

INSTALLATION NOTES

General

The representation of components in this chapter which are not within scope of the delivery is only symbolic. The design shown in this chapter does not represent a specified execution but should support the understanding of the system.

The final design, the selection and specification of parts according to the respective applicable regulations, the consideration of the system limitations and interface description as well as the comprehension of the operating limits in every operational state is in the responsibility of the aircraft manufacturer.

The aircraft manufacturer has to make sure that the operating limits given in the Operators Manual (OM) can be supervised by the pilot. The execution of the installation must allow the operation of the engine according to the Operators Manual (OM).

ENGINE SUSPENSION

NOTICE

During engine installation take into account the total engine weight and ensure careful handling.

The rubber mounts for neutralizing vibrations and other engine suspension components are not in the scope of delivery. Those components must be designed, selected and tested on vibration behavior during ground runs and flight testing at specified loads.

NOTICE

The engine suspension must be designed to prevent excessive engine movement and to minimize noise emission and vibration on the airframe.

The engine suspension is determined essentially by the aircraft design. Four attachment points are provided on the engine suspension frame assy.

The engine will be supplied with a well tried and certified suspension frame for attachment on the fireproof bulkhead. The exhaust system and the turbo charger are supported on this frame, too. The installation into the aircraft is as generally practised by captive rubber mounts which ensure also to reduce vibrations and sound transmission from engine to aircraft frame.

BRP-Rotax INSTALLATION MANUAL

⚠ WARNING

The hex. screws M10x60 on the attachment points R2 and L2 are only used for transport securing but must never be utilized for engine suspension. See interface overview. Therefore, use the ROTAX engine suspension frame and the 4 stated attachment points R2, L2, R3, L3.

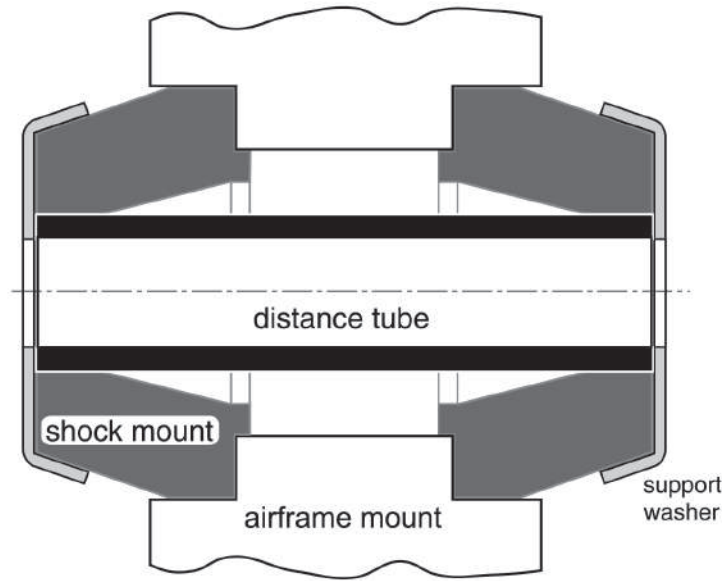

AE 51S_0167

Figure 5.9: Damping element engine suspension

Standard aircraft industry damping elements (e.g. Lord) are suitable and need to be chosen according to the aircraft specific design requirements. Check with the relevant equipment manufacturer.

The vibration and acoustic insulation factor depends on the airframe.

BRP-Rotax
INSTALLATION MANUAL

Chapter: 72-60-00
AIR INTAKE SYSTEM

TOPICS IN THIS CHAPTER

System description **3**
 System limitations 3

Interface description **6**
 Interface overview 6
 Mechanical interfaces 7
 Pneumatic interfaces 8
 Electrical interfaces 10

Installation notes **11**
 Installation overview 11

BRP-Rotax
INSTALLATION MANUAL

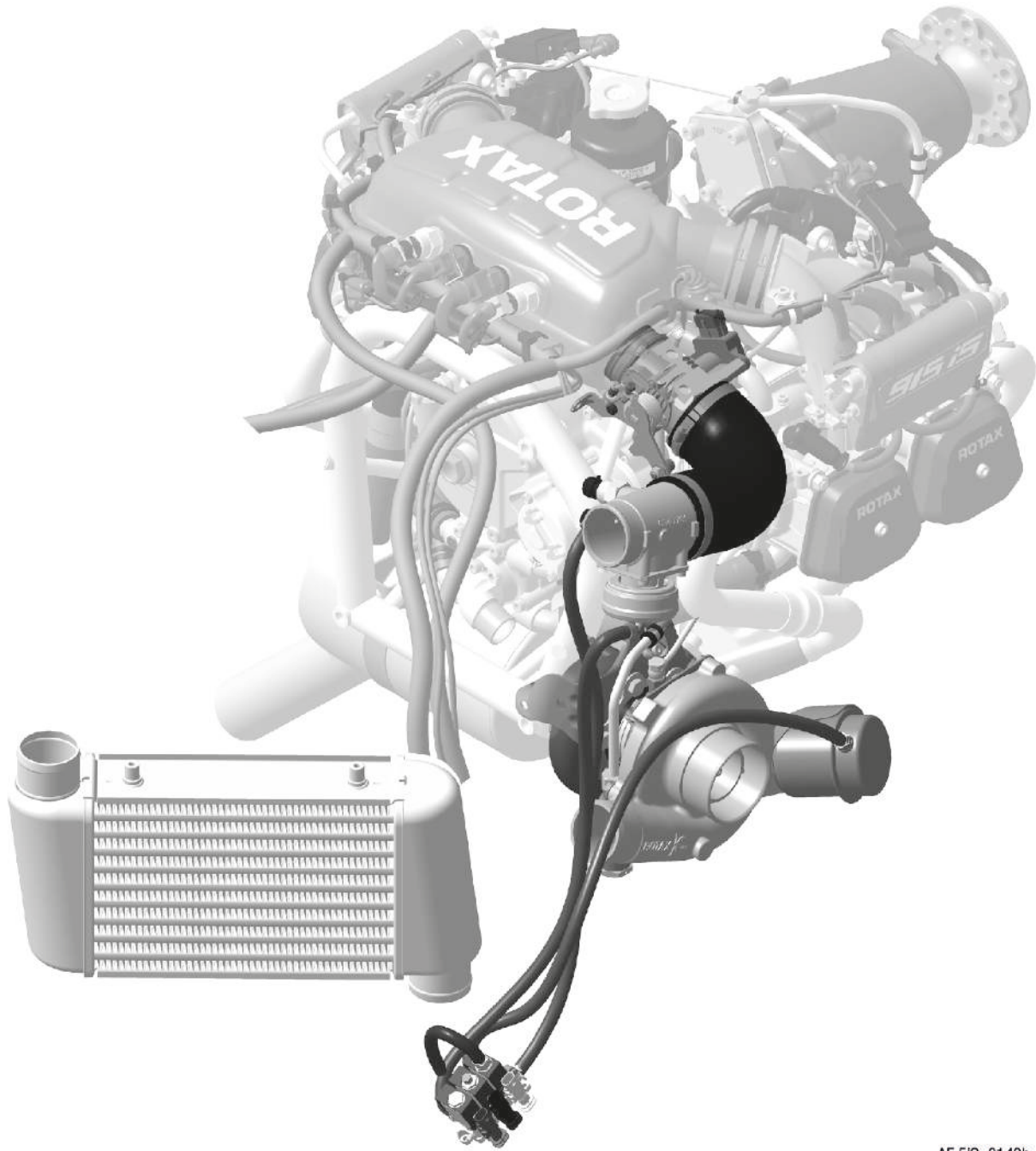

AE 51S_0148b

Figure 6.1: Air intake system

BRP-Rotax INSTALLATION MANUAL

SYSTEM DESCRIPTION

For a detailed System description refer to the latest issue of the Operators Manual (OM).

SYSTEM LIMITATIONS

Induction air intake

Following requirements may be used:

System Limit	Min.	Max.
Flow rate	400 kg/h	
Pressure loss (between ambient pressure and altitude pressure 975 mbar / 14.14 psi at ISA conditions)		10 mbar (0.14 psi)

Icing in the area of the air intake needs to be avoided. The prevention of icing lies within the aircraft manufacturer's responsibility.

Airbox reference pressure

The reference pressure of the fuel system is the airbox pressure.

Induction air intake ducting

System Limit	Min.	Max.
Intake pressure loss (Engine Speed: 5500 ±50 rpm; Airflow: 360-366 kg/h)		85 mbar (1.23 psi)
Intake pressure loss (Engine Speed: 5800 ±50 rpm; Airflow: 384-396 kg/h)		90 mbar (1.30 psi)

PCV ducting

All pneumatic hoses leading from and to the Pressure Control Valve (PCV) may not be changed. Changes in length and diameter of the hoses will have a significant effect on the wastegate control. Depending on the installation heat protection must be provided.

System Limit	Min.	Max.
Bending radius on tube centerline	60 mm	

Valid installation positions

The intercooler as well as the PCV must be installed vibration-decoupled from the engine.

Compressor housing

The turbo compressor housing must not be rotated. The wastegate functionality would be affected.

BRP-Rotax

INSTALLATION MANUAL

Throttle lever

Adjust Bowden cable such that throttle valve can be fully opened and closed.

Step	Procedure
1	Push to "full throttle", then adjust Bowden cable so that it has 1 mm (0.04 in.) clearance (no tensioning), thereby ensured that throttle valve is completely open. NOTE <i>Spring pulls the throttle valve to full throttle position.</i>
2	Push to "idle". Set the spring-loaded screw that the throttle lever hits the stop screw with the black cap (maximum setting for lowest idle).
3	If the idling speed is too low, then open throttle lever with the spring-loaded screw until the required idling speed is reached
4	Mark adjustments with locking varnish.

NOTE

It is not recommended to install a throttle limiter. With the installation of a throttle limiter, the engine can not reach its nominal power.

BRP-Rotax INSTALLATION MANUAL

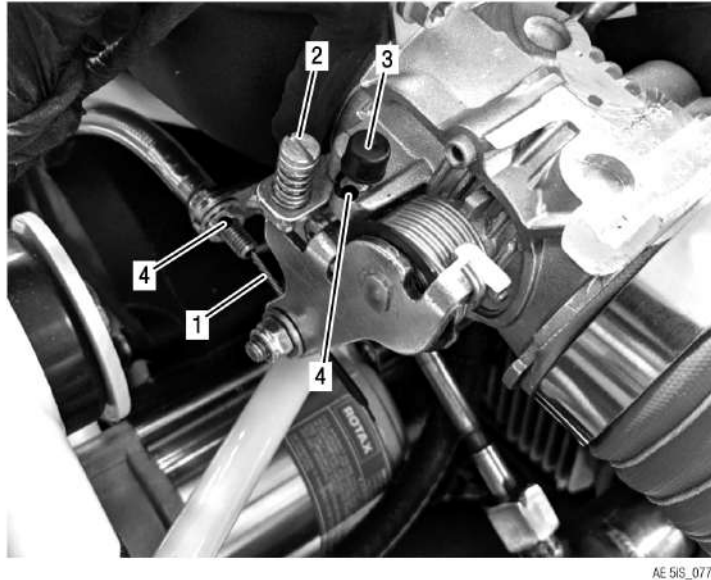

Figure 6.2: Figure shows idle position

- | | | | |
|---|--|---|---|
| 1 | Bowden cable | 2 | Spring-loaded screw (idle speed adjustment) |
| 3 | Screw with black cap (maximum setting for lowest idle speed) | 4 | Locking varnish |

⚠ WARNING

Non-compliance can result in serious injuries or death!

With throttle lever not connected the throttle valve will remain fully open. The starting position of the throttle valve is therefore full throttle! Therefore never start the engine without connecting the throttle lever first.

⚠ WARNING

Non-compliance can result in serious injuries or death!

The cable actuations being used must not be affected at all by vibrations emanating from the engine or the airframe.

BRP-Rotax
INSTALLATION MANUAL

INTERFACE DESCRIPTION

INTERFACE OVERVIEW

Interface
overview

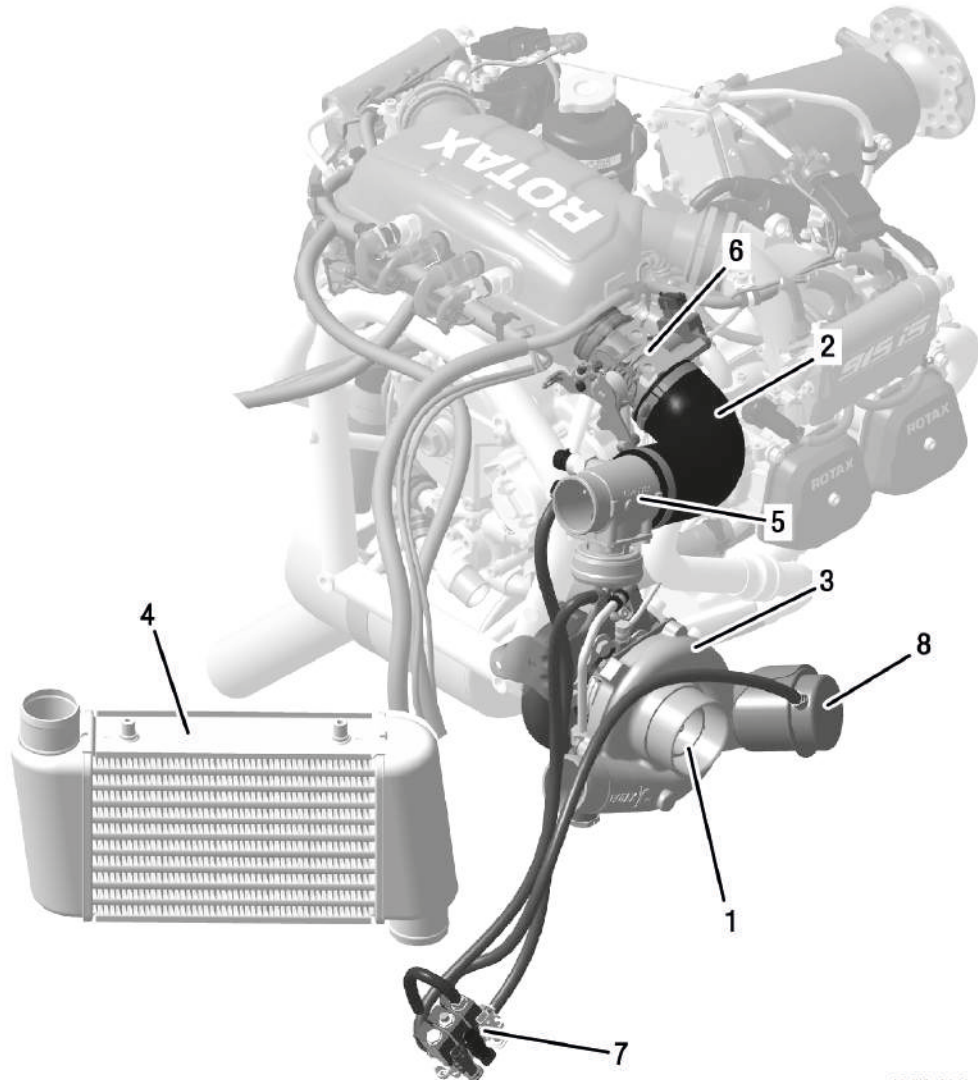

AE 5IS_0148a

Figure 6.3: Air intake: Interface overview and components

- | | | | |
|---|--|---|---|
| 1 | <i>Turbocharger inlet (pneumatic Interface)</i> | 2 | <i>Air intake hose (POP OFF valve to throttle body)</i> |
| 3 | <i>Turbocharger</i> | 4 | <i>Intercooler</i> |
| 5 | <i>POP OFF valve</i> | 6 | <i>Throttle body (mechanical interface)</i> |
| 7 | <i>Pressure Control Valve (PCV) (electrical interface)</i> | 8 | <i>Wastegate (boost pressure valve)</i> |

BRP-Rotax INSTALLATION MANUAL

MECHANICAL INTERFACES

Pressure control valve (PCV)

Interface Parameter	Min.	Max.
Tightening torque	—	1 Nm (9 in. lb)

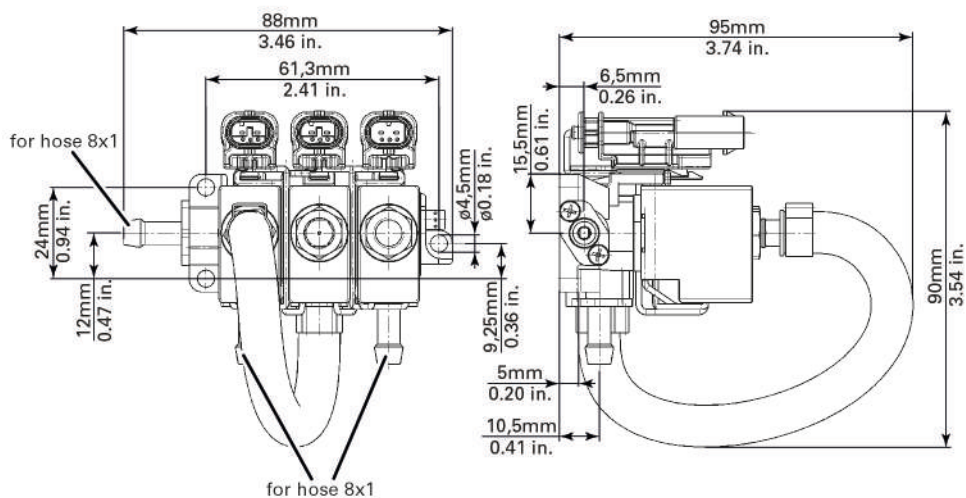

AE 5IS_0665

Figure 6.4: PCV: Connection and dimensions

Throttle body

Interface Parameter	Min.	Max.
Tightening torque	4 Nm (35 in. lb) (suitable for flexible cable), 1.5 mm (0.06 in.) steel rope or single-strand wire	—
Cable travel	65 mm (2.56 in.)	—
Actuating force	7.5 N (1.69 lbs.)	20 N (4.5 lbs)
Max. permissible actuating force	—	20 N (4.5 lbs)

Connection: Set screw M6x12 mm

BRP-Rotax INSTALLATION MANUAL

Intercooler

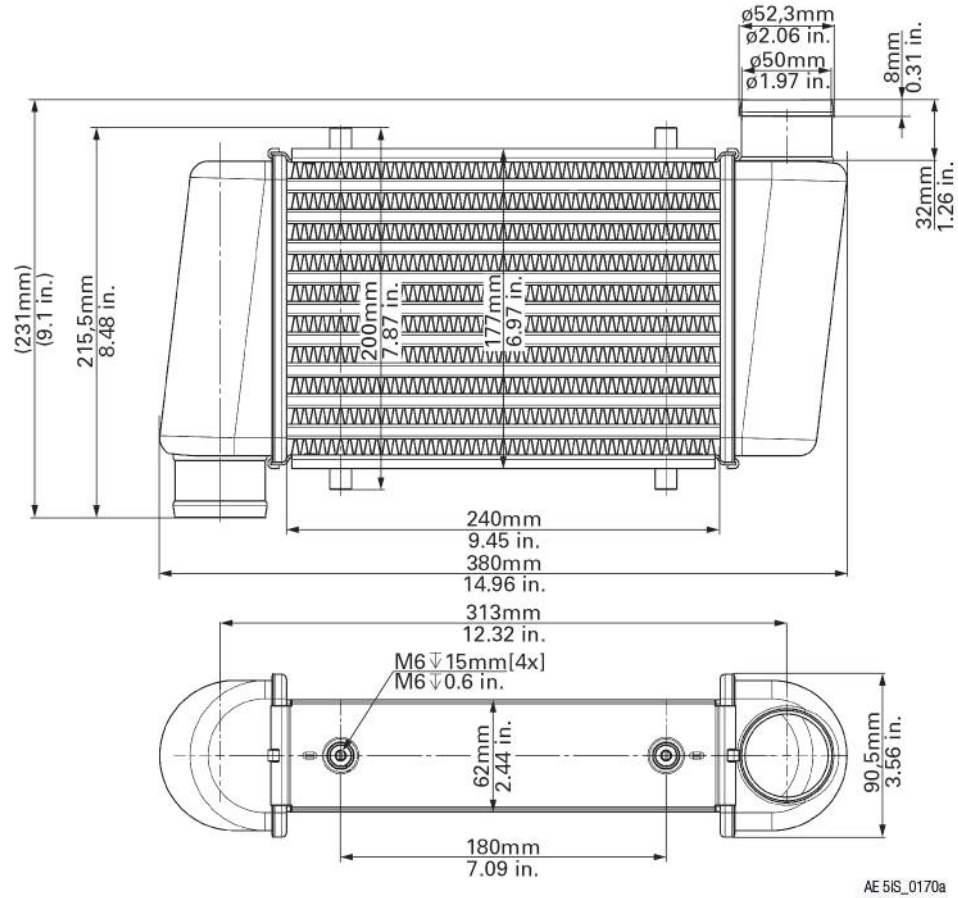

Figure 6.5: Intercooler: Connection and dimensions

To attach the intercooler within the airframe design four suitable fixation points are available and M6 screws must be used.

NOTICE

Make sure proper dampening of the 4 fixation points and assure stress free installation on these 4 fixation points.

PNEUMATIC INTERFACES

Airfilter connection

See figure Connection on turbocharger

Interface Parameter	Min.	Max.
Slip-on length	30 mm (1.18 in.)	-

BRP-Rotax INSTALLATION MANUAL

NOTE

Use only filter elements which will not tend to restrict the flow when in contact with water.

**Turbocharger to
intercooler**

Connection on turbocharger:

Interface Parameter	Min.	Max.
Slip-on length	30 mm (1.18 in.)	-

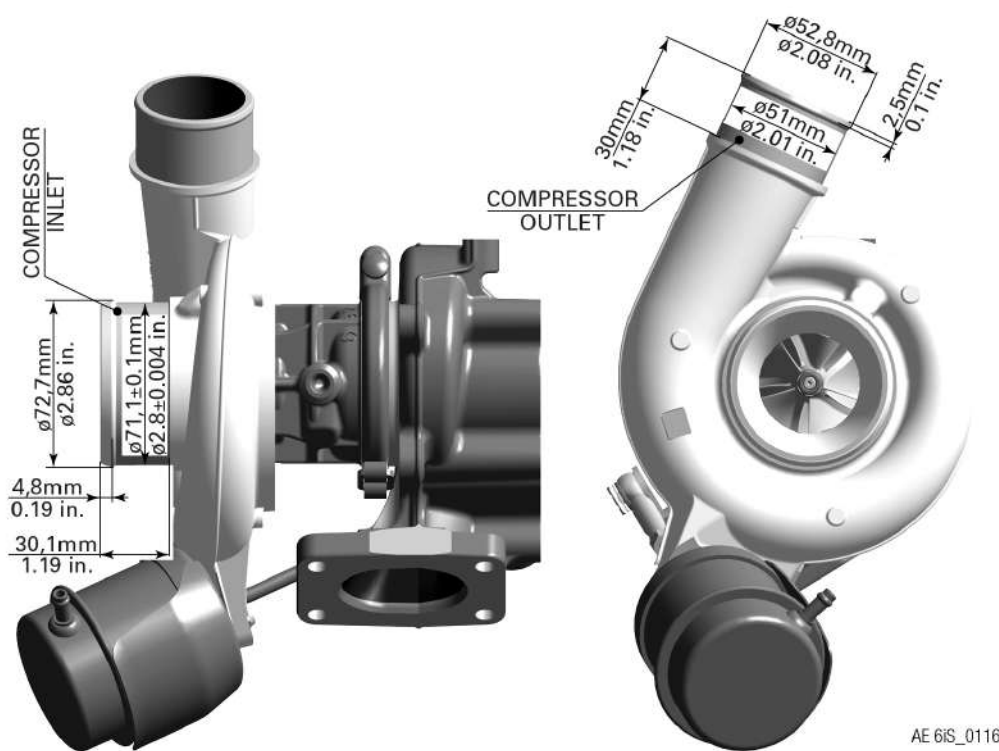

AE 6IS_0116

Figure 6.6: Connection on turbocharger, TYPICAL

BRP-Rotax INSTALLATION MANUAL

Connection on intercooler:

Interface Parameter	Min.	Max.
Slip-on length	32 mm (1.26 in.)	-

See [Figure 6.5: Intercooler: Connection and dimensions](#)

Intercooler to POP OFF valve

Interface Parameter	Min.	Max.
Slip-on length	18 mm (0.71 in.)	

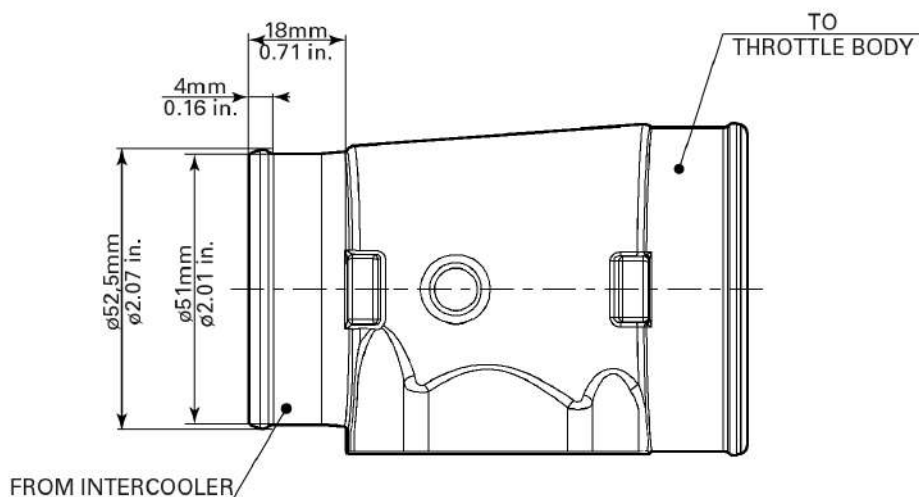

AE 5IS_0374

Figure 6.7: POP OFF valve

Connection on throttle body: Install the delivered hose (scope of supply) to the correct side of the POP OFF valve, recheck if it fits.

ELECTRICAL INTERFACES

PCV sockets

The appropriate connectors on the wiring harness as well as the corresponding sockets on the PCV are color coded.
To avoid inappropriate behavior of the wastegate the correct linkage needs to be ensured.

BRP-Rotax INSTALLATION MANUAL

INSTALLATION NOTES

General

The representation of components in this chapter which are not within scope of the delivery is only symbolic. The design shown in this chapter does not represent a specified execution but should support the understanding of the system.

The final design, the selection and specification of parts according to the respective applicable regulations, the consideration of the system limitations and interface description as well as the comprehension of the operating limits in every operational state is in the responsibility of the aircraft manufacturer.

The aircraft manufacturer has to make sure that the operating limits given in the Operators Manual (OM) can be supervised by the pilot. The execution of the installation must allow the operation of the engine according to the Operators Manual (OM).

INSTALLATION OVERVIEW

Pneumatic diagram

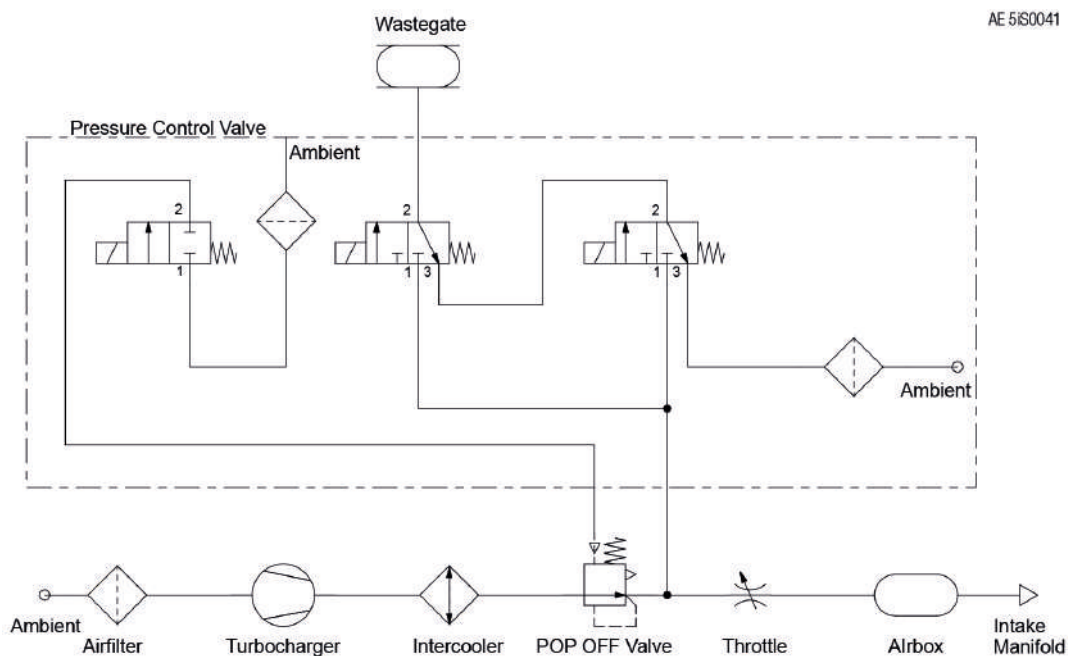

Figure 6.8: Pneumatic diagram

Connection between compressor outlet and intercooler

Temperature-resistant hoses must be used.

BRP-Rotax
INSTALLATION MANUAL

INTENTIONALLY LEFT
BLANK

BRP-Rotax
INSTALLATION MANUAL

Chapter: 73-00-00
ENGINE – FUEL AND CONTROL

TOPICS IN THIS CHAPTER

System Description	3
System limitations	3
Interface description	4
Interface overview	4
Hydraulic interfaces	6
Electrical interfaces – 916 I Type A	6
Electrical interfaces – 915 I Type C24	7
Mechanical interfaces	7
Installation notes	8
Installation overview	9
Fuel lines	10
Inlet line	10
Return line	10
Bypass line	10
Coarse filter	11
Water trap, gascolator	11
Fine filter	11
Fuel pump	12
Fuel pressure sensor	12
Fuel pressure regulator	12
Fuel tank	12
Fuel shut off valve	13

BRP-Rotax
INSTALLATION MANUAL

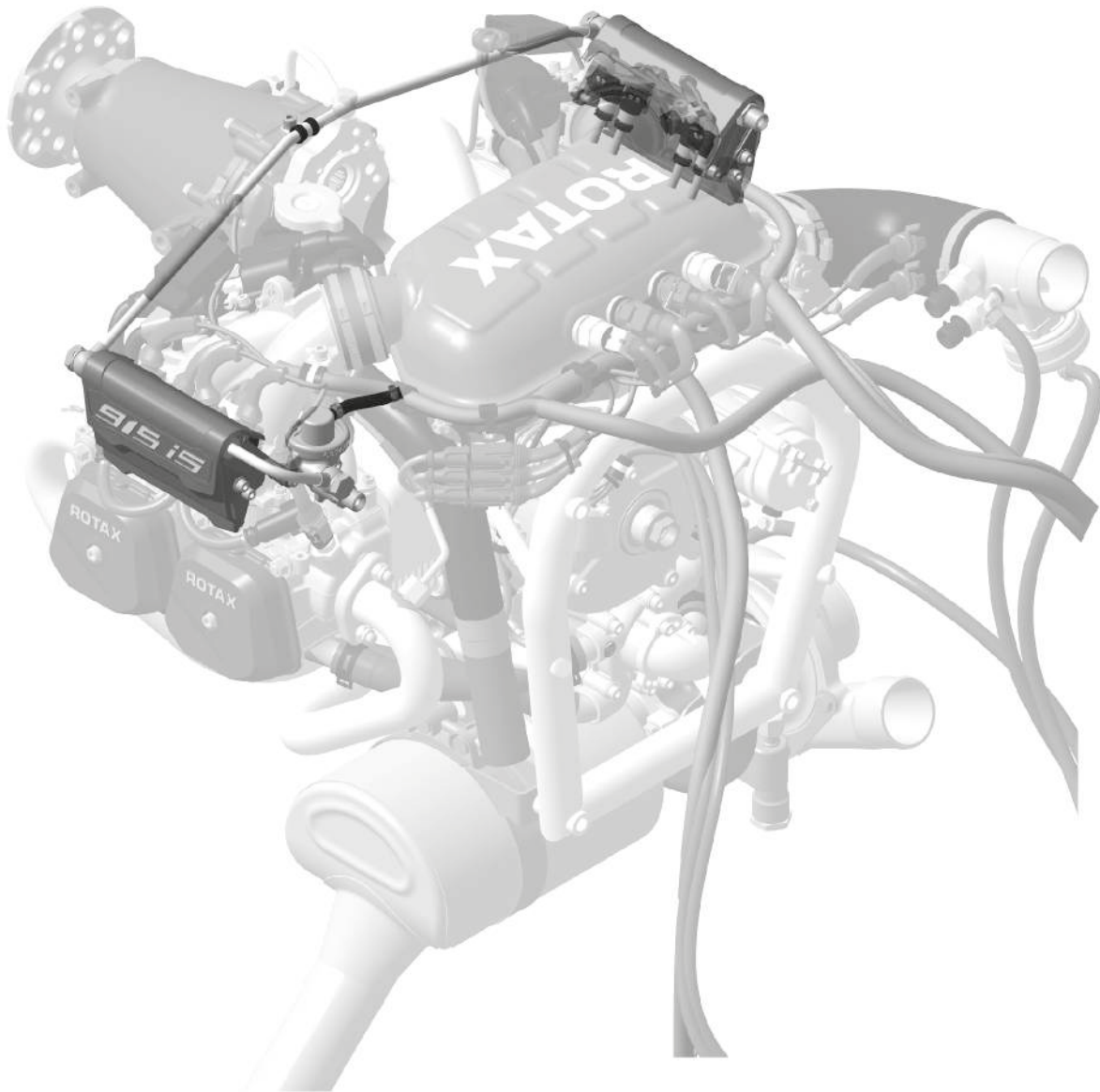

AE 51S_0171

Figure 7.1: Fuel System

BRP-Rotax
INSTALLATION MANUAL

SYSTEM DESCRIPTION

For a detailed System description refer to the latest issue of the Operators Manual.

SYSTEM LIMITATIONS

Operating limits Refer to latest issue of the Operators Manual (OM).

BRP-Rotax
INSTALLATION MANUAL

INTERFACE DESCRIPTION

INTERFACE OVERVIEW

915 i TYPE A

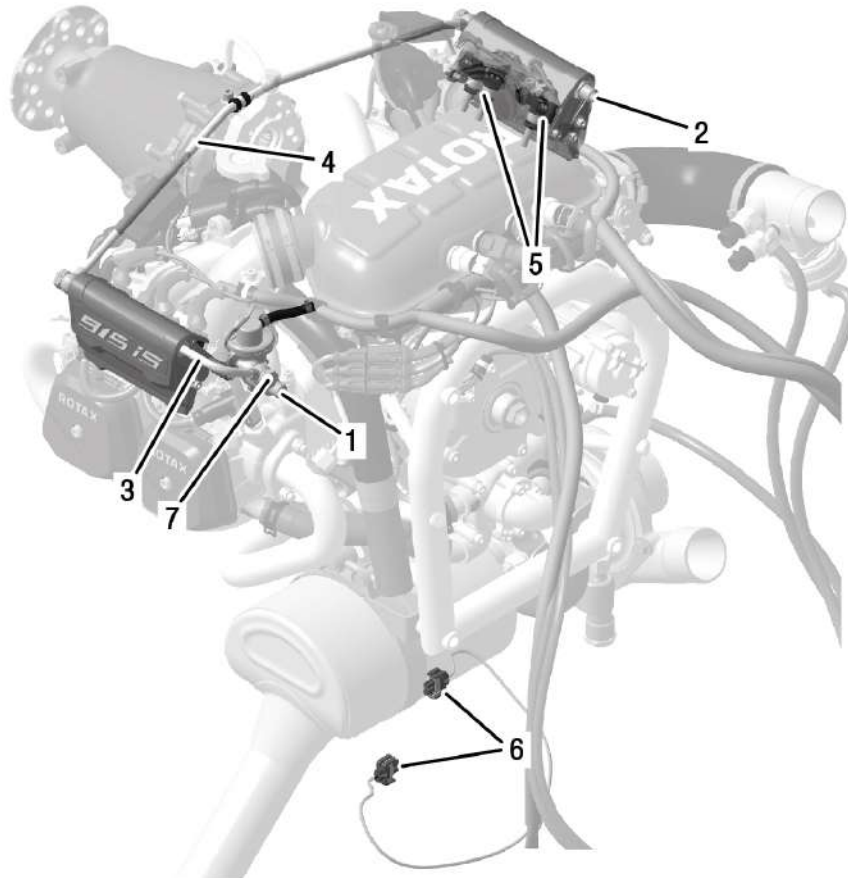

AE 515_0172

Figure 7.2: Fuel System: Interface overview and components

- | | | | |
|---|---|---|---|
| 1 | Fuel rail 2/4 outlet line (hydraulic Interface) | 2 | Fuel rail 1/3 feed line (hydraulic Interface) |
| 3 | Fuel rail | 4 | Fuel line assy. |
| 5 | Injection valves | 6 | Fuel pump connectors (electrical interface) |
| 7 | Banjo bolt | | |

BRP-Rotax INSTALLATION MANUAL

915 i TYPE C24

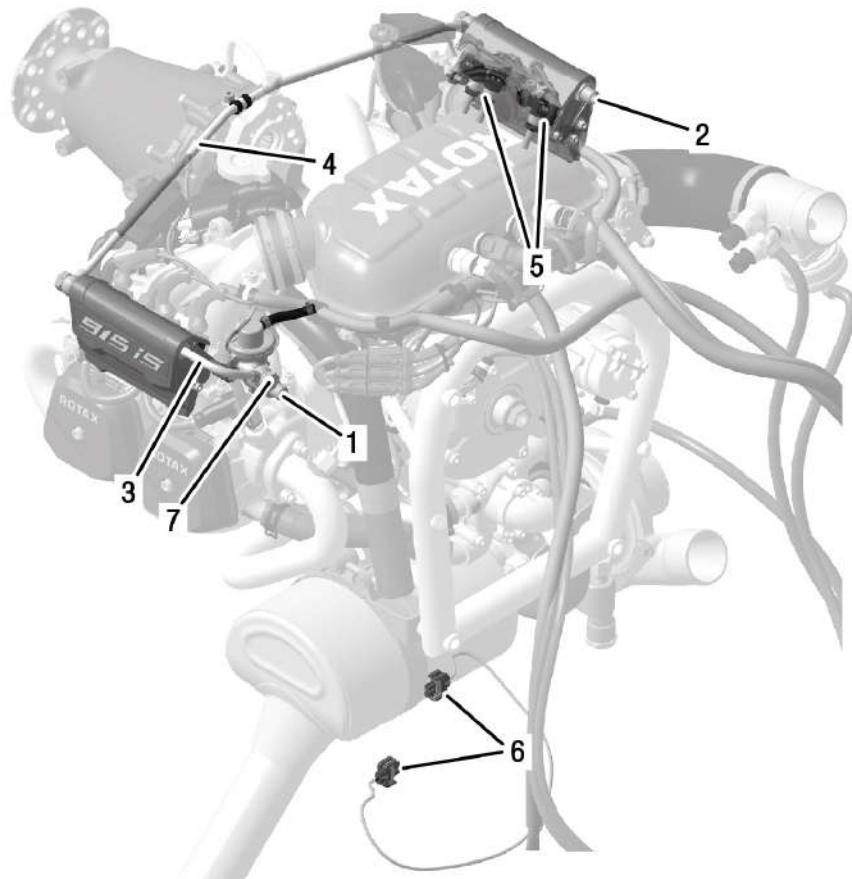

AE 516_0172

Figure 7.3: Fuel System: Interface overview and components

- | | | | |
|---|---|---|---|
| 1 | Fuel rail 2/4 outlet line (hydraulic Interface) | 2 | Fuel rail 1/3 feed line (hydraulic Interface) |
| 3 | Fuel rail | 4 | Fuel line assy. |
| 5 | Injection valves | 6 | Fuel pump connectors (electrical interface) |
| 7 | Banjo bolt | | |

BRP-Rotax

INSTALLATION MANUAL

HYDRAULIC INTERFACES

NOTICE
Independent from the ambient conditions (e.g. fuel pressure and temperature) and independent from the fuel used the design of the fuel system must prevent vapour lock conditions. Vapour lock may result in engine stoppage.

	Interface Parameter	Min.	Max.
Fuel inlet	Fuel pressure (relative to MAP)	2.9 bar (42 psi)	3.2 bar (46 psi)
	Acceptable Fuel pressure exceedance (max. 3 sec.)	2.5 bar (36 psi)	3.5 bar (51 psi)
	NOTE <i>Fuel pressure exceedance only allowed after power setting change</i>		
	Fuel pressure oscillation (min. sample rate 20 kHz)	-	1.0 bar (14.5 psi), peak-to-peak
	Fuel flow	56 l/h (14.8 gal/h)	150 l/h (39.6 gal/h)
	Fuel quality	EN 228	-

Fine filter quality **NOTE**
Nominal rating 8 – 12 µm, minimum 82 % capture efficiency according to ISO 19438 (edition 11/2003), dirt particles > 35 µm are not permissible.

Connection: M14x1.5 or AN-6 (9/16-18 UNF).

	Interface Parameter	Min.	Max.
Fuel outlet	Fuel pressure (relative to Fuel Tank pressure)	-	0.5 bar (7.3 psi)

Connection: M14x1.5 or AN-6 (9/16-18 UNF).

ELECTRICAL INTERFACES – 916 I TYPE A

	Interface Parameter	Min.	Max.	Nominal
Fuel pump connectors	Output Voltage (V)	12 V	14.5 V	13.8 V
	Output Current (A)	Fuel pump assy. (both pumps):		
		7 A	10.5 A	–
	Output Current (A)	Single pump:		
		4.5 A	7.5 A	–

BRP-Rotax INSTALLATION MANUAL

ELECTRICAL INTERFACES – 915 I TYPE C24

Fuel pump
connectors

915 i TYPE C 24

Interface Parameter	Min.	Max.	Nominal
Output Voltage (V)	12 V	14.5 V	13.8 V
Output Current (A)	Fuel pump assy. (both pumps): @ 12 V = 9.1 A [+/- 2 A]		
	Single pump: @ 12 V = 5 A [+ 2.5 A / - 0.5 A]		

Cockpit Airframe
side

Connector	PIN	Function	Type
X4	A	14 V (for EMS, Battery Backup)	Output
	B	14 V GND (for EMS, Battery Backup)	Output
	C	14 V (for Fuel Pump 2 / Aux.)	Output
	D	14 V GND (for Fuel Pump 2 / Aux)	Output

MECHANICAL INTERFACES

Adapter for fuel
pressure

Standard banjo bolt can be replaced by an optional Sensor adapter for connectivity directly on the fuel inlet of the fuel pressure regulator. See SI-PAC-024.

Interface Parameter	Min.	Max.
Tightening torque	23 Nm (17 ft. lb)	27 Nm (20 ft.lb)
Component mass (adapter with sensor)	-	80 g

Connection: M12 x 1.5

BRP-Rotax INSTALLATION MANUAL

INSTALLATION NOTES

General

The representation of components in this chapter which are not within scope of the delivery is only symbolic. The design shown in this chapter does not represent a specified execution but should support the understanding of the system.

The final design, the selection and specification of parts according to the respective applicable regulations, the consideration of the system limitations and interface description as well as the comprehension of the operating limits in every operational state is in the responsibility of the aircraft manufacturer.

The aircraft manufacturer has to make sure that the operating limits given in the Operators Manual (OM) can be supervised by the pilot. The execution of the installation must allow the operation of the engine according to the Operators Manual (OM).

BRP-Rotax INSTALLATION MANUAL

INSTALLATION OVERVIEW

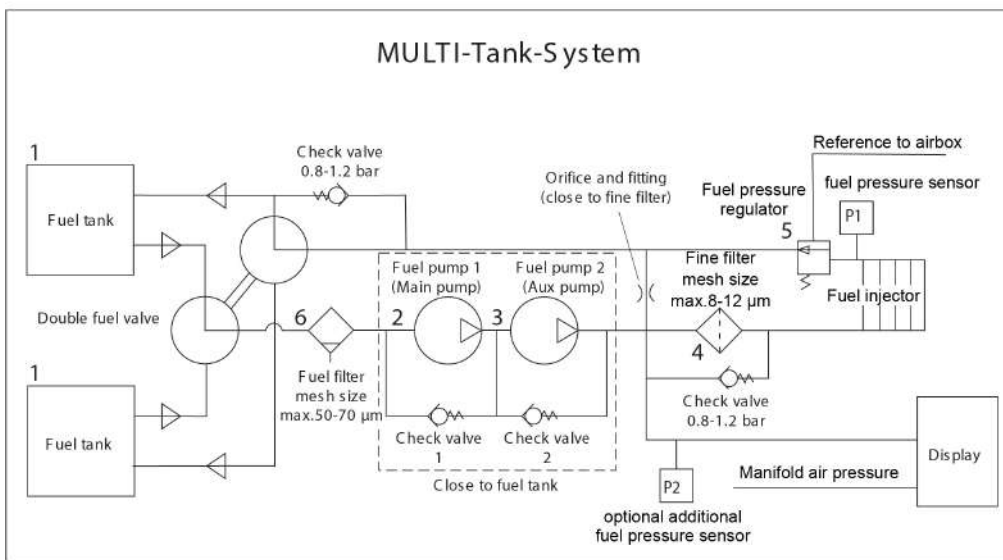
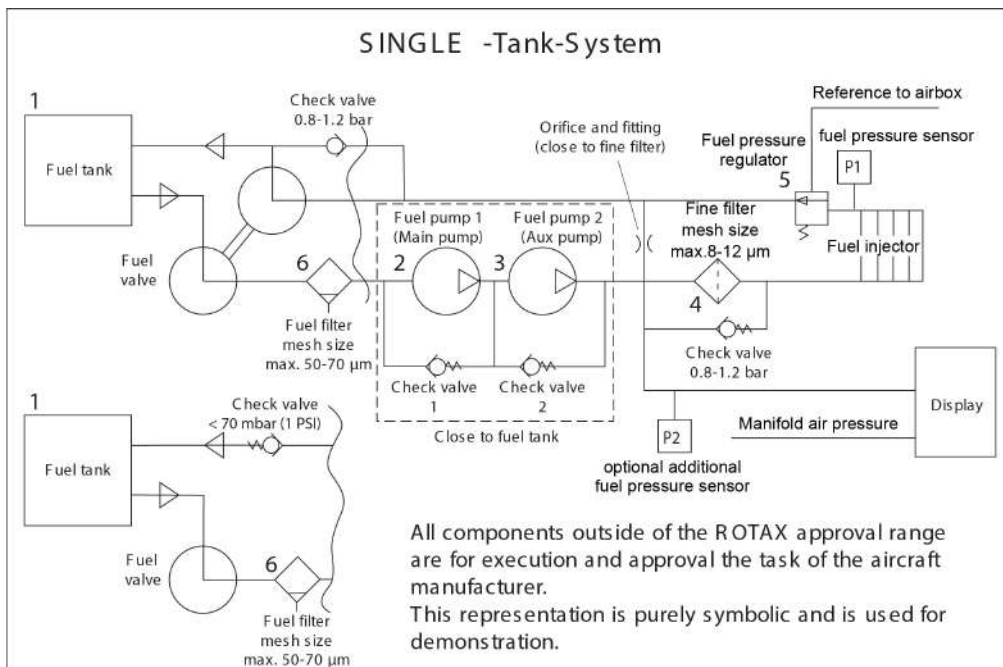

AE5IS_0783_a

Figure 7.4: Fuel system

- | | |
|---------------------------|----------------------------|
| 1 Fuel tank | 2 Fuel pump 1 |
| 3 Fuel pump 2 | 4 Fine filter |
| 5 Fuel pressure regulator | 6 Coarse filter/water trap |

BRP-Rotax INSTALLATION MANUAL

FUEL LINES

To prevent problems with vapour lock, all the fuel lines should be insulated against heat in the engine compartment. It is recommended to route the fuel lines in an appropriate distance from hot engine components and avoid sharp bends.

For a better heat dissipation it is recommended to use fuel lines made of metal whenever practicable (except for flex hoses to/ from engine).

Fuel lines should be installed by using suitable screw clamps or by ferrules.

Non drainable low points in feed, return and vent lines should be avoided. Any low points should allow for drainage of water and other contaminants.

⚠ WARNING

Non-compliance can result in serious injuries or death!

At the low points, accumulations of water can freeze and cut off the fuel flow.

INLET LINE

The inlet line should have an inner diameter of at least 7.5 mm (0.3 in). (AN-6 or 3/8").

NOTICE

Fuel lines smaller than this diameter may have a significant impact on the proper functionality of this engine.

RETURN LINE

The return line should have an inner diameter of at least 7.5 mm (0.3 in). (AN-6 or 3/8").

NOTICE

Fuel lines smaller than this diameter may have a significant impact on the proper functionality of this engine.

Vapour locks in the return line should be efficiently vented out of the fuel system to the atmosphere. Adequate fuel tank venting system design is imperative. Large vent lines with (most) direct routing avoiding low points are desired.

BYPASS LINE

To allow venting of the fuel system and better fuel pump engagement after a potential inclusion of air, there could be installed a restricted bypass line between the inlet (pressure side of the fuel pump module) and the return line. In this bypass line a restricted orifice should be installed so that there is an ideal balance between short venting time and minimum fuel flow rate. The positioning and dimensioning of the orifice is up to the aircraft manufacturer.

If no bypass line is installed, the pressure release in the fuel lines is very slow. This should be noted accordingly in the manuals of the aircraft manufacturer (fuel lines are possibly under full operating pressure even after engine stop).

BRP-Rotax INSTALLATION MANUAL

NOTE

The switching between several fuel tanks at power loss due to fuel shortage should be given within a defined period of time and without falling below the minimum performance limit and must be ensured by the aircraft manufacturer. Refer to the latest requirements such as FAR or EASA.

COARSE FILTER

The coarse filter should be installed at an easily accessible position to allow a periodic inspection.

Following fuel filter could be used to ensure that the engine is supplied with fuel of an adequate quality:

Interface Parameter	Min.	Max.
Filter mesh size	50 micron (0.0019 in.)	70 micron (0.0027 in.)
Filter surface (total)	64.4 cm ² (10 in ²)	-
Passing area	18.4 cm ² (2.85 in ²)	-

The filter should be installed in the supply line between the tank and the fuel pumps and should be of sufficient capacity to prevent complete blockage between maintenance intervals.

NOTICE

An installation without coarse filter may have a significant impact on the proper functionality of this engine.

WATER TRAP, GASCOLATOR

A suitable water trap must be installed. Certification according to the latest regulations, such as FAR or EASA, must be conducted by the aircraft or fuselage manufacturer.

FINE FILTER

The fine filter should be installed at an easy accessible position to allow a periodic inspection. To ensure that the engine is supplied with fuel of an adequate quality, a fine filter with following specifications should be installed between the fuel pumps (module) and the injection rail (Cylinder 1/3):

Interface Parameter	Min.	Max.
Filter mesh size	8 micron	12 micron
Fuel flow rate	90 l/h (23.8 gal/h)	-
Differential pressure		0.02 bar (0.29 psi)

BRP-Rotax INSTALLATION MANUAL

NOTICE

An installation without fine filter may have a significant impact on the proper functionality of this engine.

FUEL PUMP

For reducing the risk of vapor lock, the fuel pump should be placed in a well-ventilated area. A recommended installation position would be near the fuel tank in order to ensure a safe fuel supply.

FUEL PRESSURE SENSOR

The operating limit of the fuel pressure should be observed at the inlet of the fuel pressure regulator.



See the relevant SI-PAC-024 “Optional fuel pressure adapter”, current issue.

An additional fuel pressure sensor could be placed before the fine filter, so the filter load can be checked. An increase of fuel pressure over the allowed limit could mean that the fine filter is becoming contaminated. The fine filter should be checked and replaced if necessary.

FUEL PRESSURE REGULATOR

Fuel pressure regulators have very precise tolerances and are generally reliable. Mostly pressure fluctuations are not caused by the pressure regulator, they might be found in other sections (filter clogged, pulsation of lines, kinks in the hoses etc.) of the fuel system.

FUEL TANK

In case of supply problems of the fuel pump, the fuel tank should be emptied and filled with AVGAS. If the problem does not occur at the next test (with AVGAS), then this is a sign of formation of vapour locks when using MOGAS (or auto fuel).

Following points may have a positive impact on the proper functionality of this engine:

- Single tank (large volume of fuel in the tank, just a few fuel lines)
- Catch tanks in the wing tanks. This provides the fuel supply in every flight situation/ position
- Header tank (the following reference values should be considered):

BRP-Rotax INSTALLATION MANUAL

Interface Parameter	Specification
Venting line	The venting line from header tank to wing tank should generally be on an incline to avoid trapping bubbles. The venting line must have an inner diameter of at least 12 mm (0.50 in).
Feed lines	Fuel feed lines from the wing tanks to the header tank should be on a steady decline.

Following points may have a negative impact on the proper functionality of the engine:

- A header tank design that enables the re-entry of vapour bubbles in the suction line
- Multi tank system without catch-, header tank

FUEL SHUT OFF VALVE

The fuel shut off valve position on the pressure side of the fuel system (after the fuel pump module) can have an unfavorable impact on the installation of the engine.

BRP-Rotax
INSTALLATION MANUAL

INTENTIONALLY LEFT
BLANK

BRP-Rotax
INSTALLATION MANUAL

Chapter: 75-00-00
COOLING SYSTEM

TOPICS IN THIS CHAPTER

System Description	3
System limitations	3
Interface description	4
Interface overview	4
Hydraulic interfaces	5
Air Cooling interfaces	7
Installation notes	10
Installation overview	10
Water inlet elbow	11
Expansion tank	11
Coolant hoses	11
Coolant	12
Validation of installation	13

BRP-Rotax
INSTALLATION MANUAL

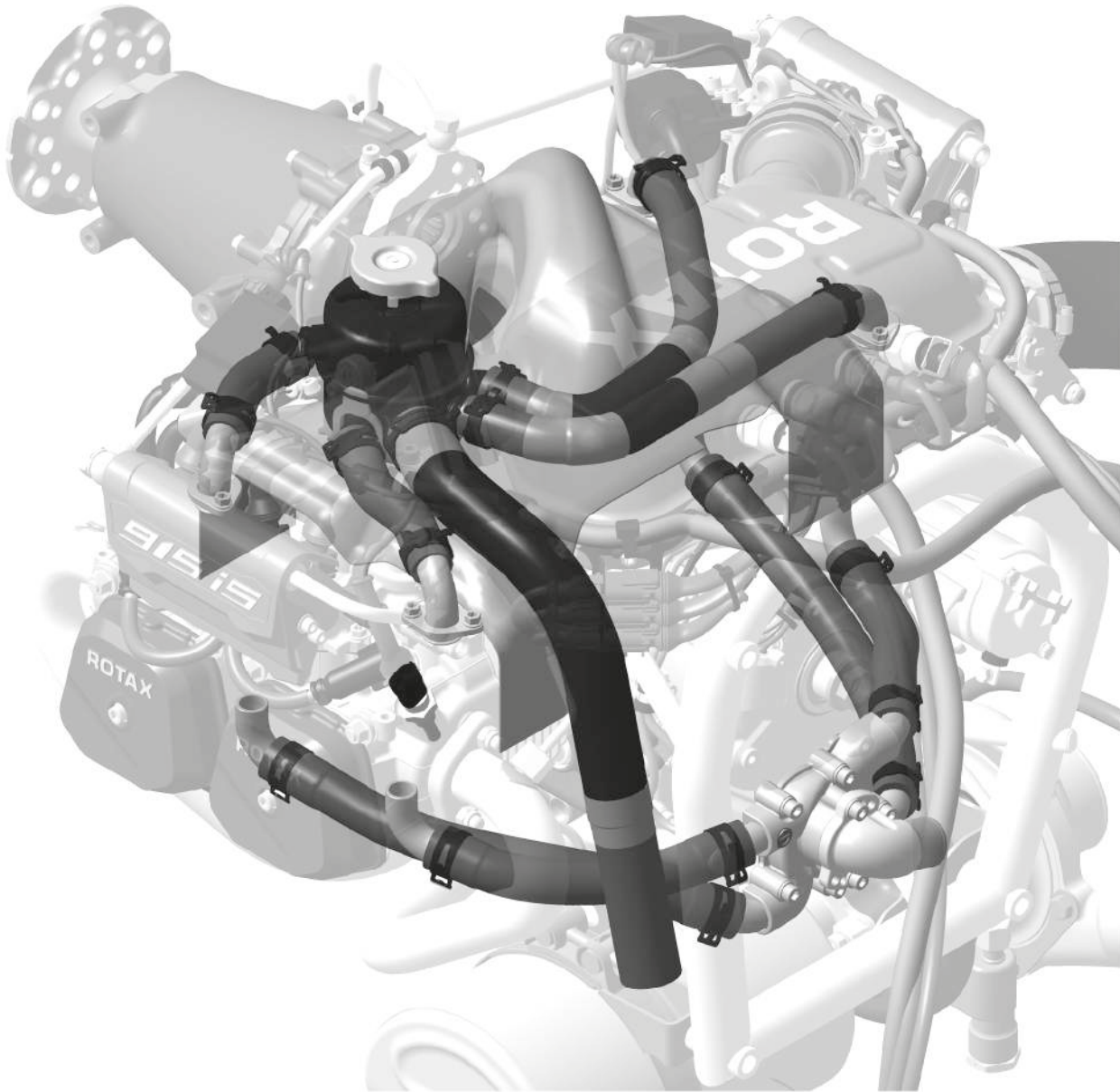

AE 5S_0174

Figure 8.1: Cooling System

BRP-Rotax INSTALLATION MANUAL

SYSTEM DESCRIPTION

For a detailed System description refer to the latest issue of the Operators Manual (OM).

SYSTEM LIMITATIONS

Operating limits Refer to latest issue of the Operators Manual (OM).

⚠ WARNING

Non-compliance can result in serious injuries or death!

The cooling system must be designed so that operating temperatures will not exceed the maximum values.

Coolant types It is important that the coolant circuit is designed so that the coolant does not reach boiling point under any conditions. If the temperature exceeds the boiling point, the engine can quickly overheat due loss of coolant.

The boiling point of the coolant is mainly influenced by:

- the type of coolant
- mixture ratio (percentage water rate)
- the system pressure (opening pressure of radiator cap)

For permissible coolant types see SI-915i-001, latest issue.

System pressure

System Limit	Min.	Max.
Coolant system pressure	–	1.2 bar (18 psi)

Hose connecting expansion tank to overflow bottle

System Limit	Min.	Max.
Able to withstand heat and vacuum without collapsing-able	125 °C (257 °F)	–

A soft walled hose is not suitable as it can collapse and cause cooling system failure.

Expansion tank

To ensure proper operation of the cooling system, the expansion tank with pressure cap in the main operating systems must be installed on the highest point of the cooling circuit.

BRP-Rotax
INSTALLATION MANUAL

INTERFACE DESCRIPTION

INTERFACE OVERVIEW

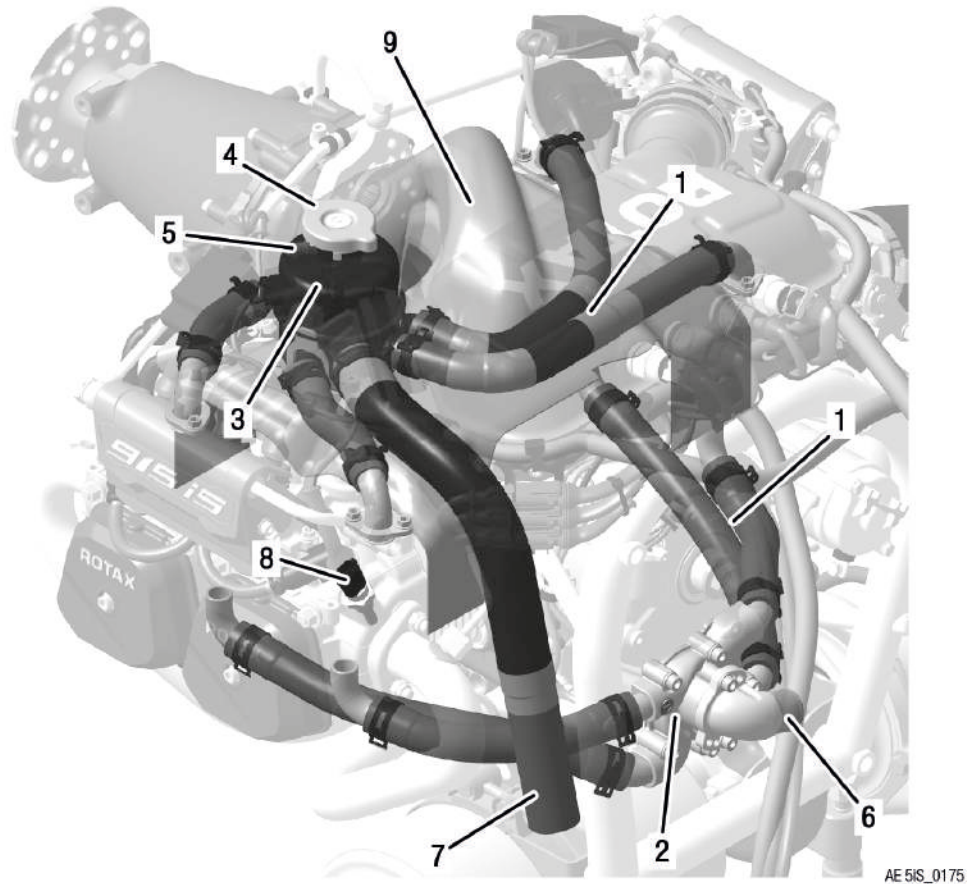

Figure 8.2: Cooling System – Interfaces

- | | | | |
|---|--|---|---|
| 1 | Coolant hose | 2 | Water pump housing |
| 3 | Expansion tank | 4 | Pressure cap |
| 5 | Expansion tank to overflow bottle connection (hydraulic Interface) | 6 | Water inlet elbow (hydraulic Interface) |
| 7 | Water outlet (hydraulic Interface) | 8 | Coolant temperature sensor |
| 9 | Cooling air baffle | | |

BRP-Rotax INSTALLATION MANUAL

HYDRAULIC INTERFACES

Water inlet elbow

Interface Parameter	Min.	Max.
Cooling system pressure (relative)	1.6 bar (23 psi)	-
Coolant temperature	- 20 °C (- 4 °F)	125 °C (257 °F)
Coolant flow (at 5800 rpm)	70 l/min (18.49 USgal/min)	-
Slip on length	19 mm (0.75 in)	

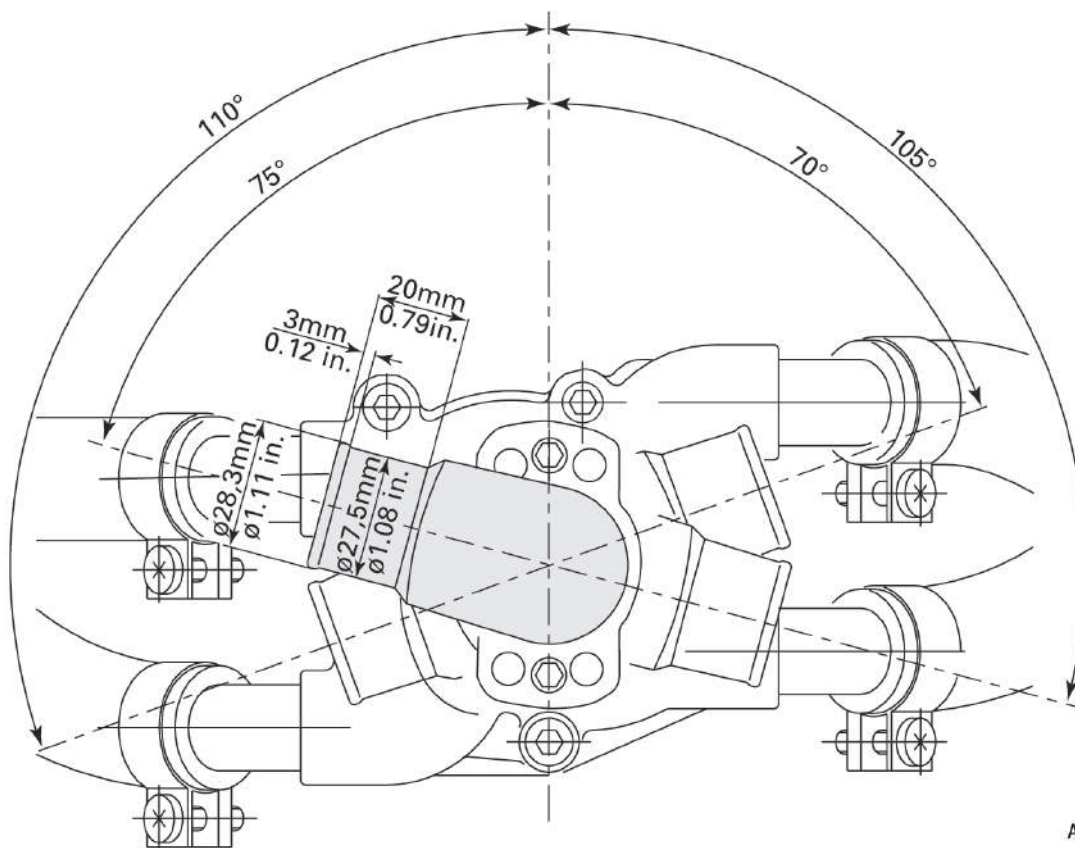

AE 5iS_0375

Figure 8.3: Water inlet elbow

Connection: Outer diameter 27 mm (1.07 in).

Water outlet

Interface Parameter	Min.	Max.
Cooling system pressure (relative)	1.6 bar (23 psi)	-
Coolant temperature	- 20 °C (- 4 °F)	130 °C (266 °F)
Coolant flow (at 5800 rpm)	70 l/min (18.49 USgal/min)	-

BRP-Rotax INSTALLATION MANUAL

Connection: Inner diameter 25 mm (0.98 in).

**Overflow bottle
connection**

Interface Parameter	Min.	Max.
Slip on length	18 mm	

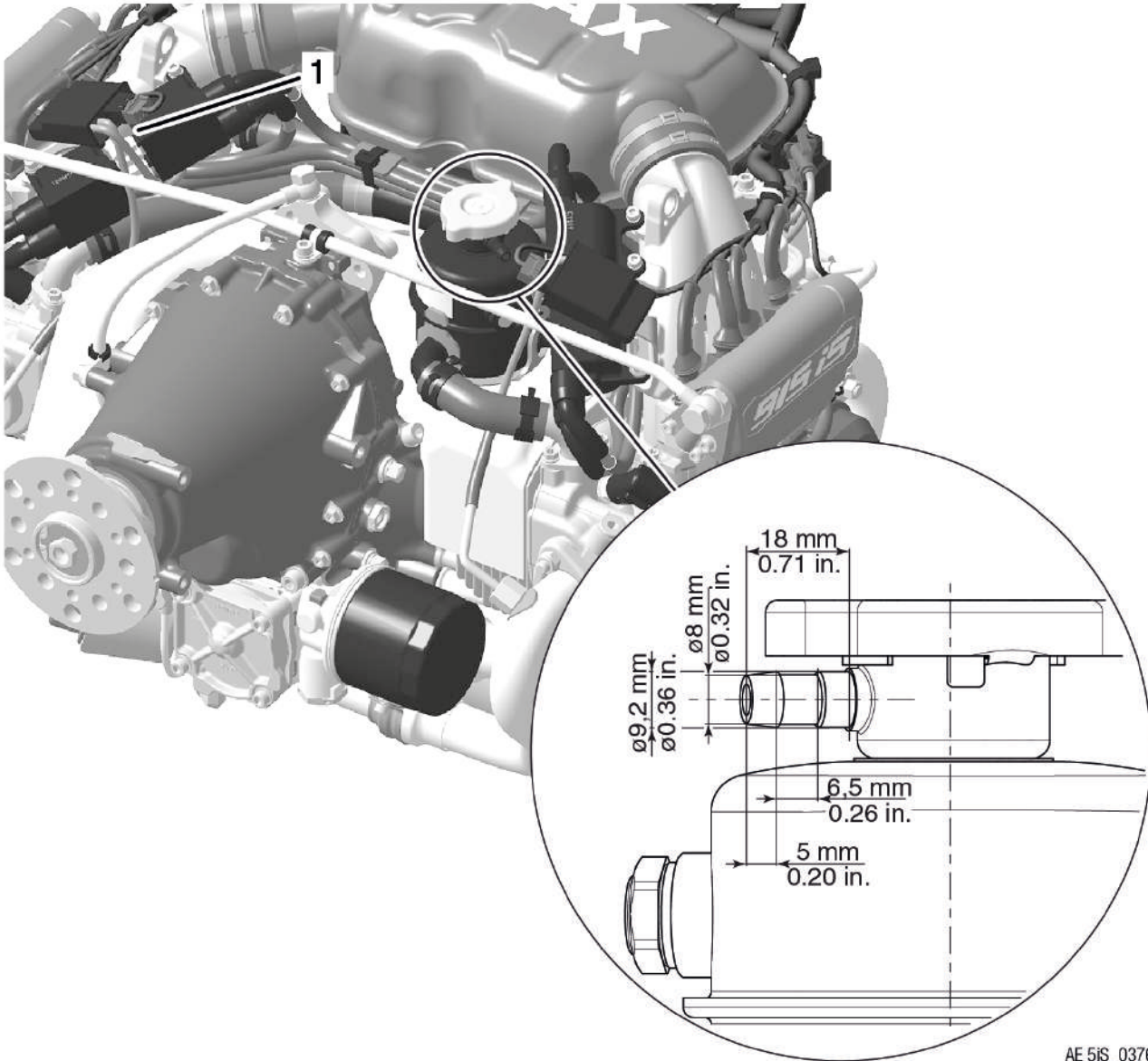

AE 5iS_0376

Figure 8.4: Overflow bottle connection

BRP-Rotax INSTALLATION MANUAL

AIR COOLING INTERFACES

Cooling air baffle

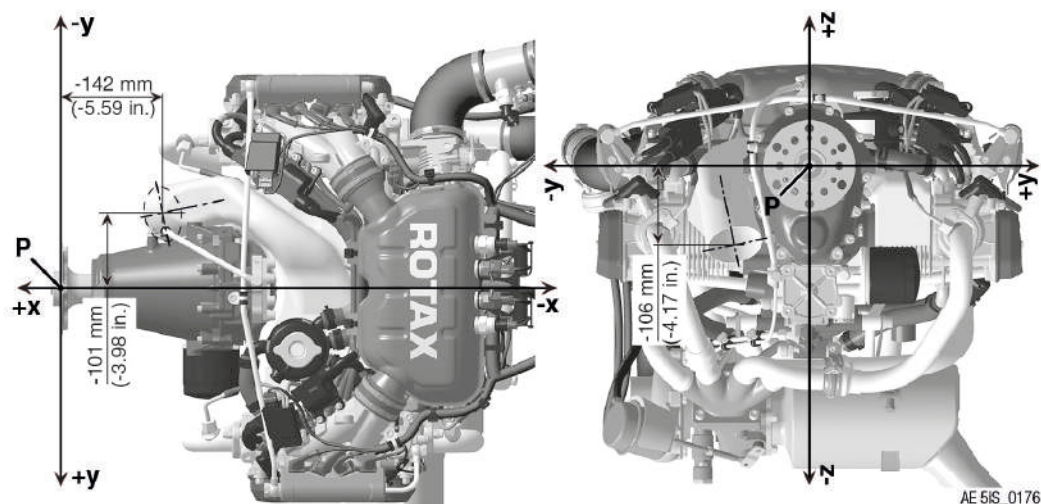

Figure 8.5: Cooling air baffle position

Position	x-axis	y-axis	z-axis
P1	- 142 mm (- 5.59 in.)	- 101 mm (- 3.98 in.)	- 106 mm (- 4.17 in.)

General information

NOTE

In some special cases a separate cold air supply to the air baffle should be provided.

Cylinder wall temperature

Max. permitted cylinder wall temperature on hottest cylinder is 200 °C (392 °F). See the following figure. The cylinder wall temperature can be measured using a thermocouple.

NOTE

If this temperature is exceeded, appropriate measures (e.g. cooling air ducts, modifications to cowling, etc.) must be taken to bring it within limits again.

BRP-Rotax INSTALLATION MANUAL

Measuring point

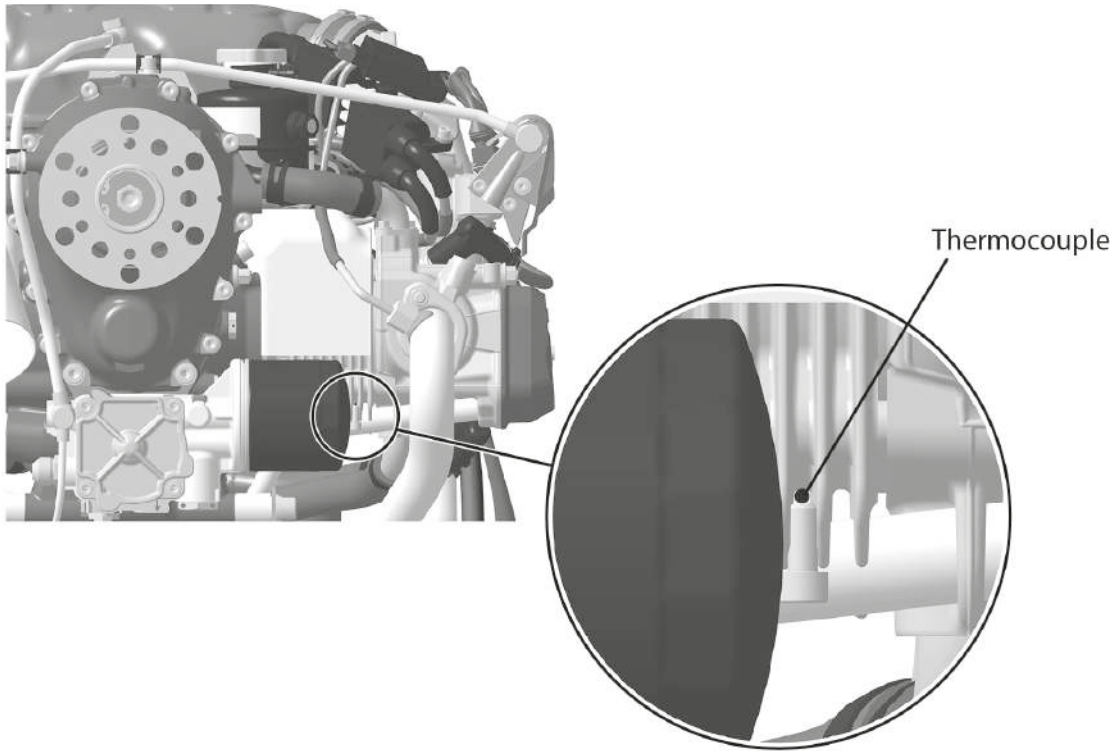

AE 5iS_00207

Figure 8.6: Measuring point TYPICAL

Following recommendations should assist the aircraft or fuselage manufacturer in selecting suitable cooling air ducts:

Specification	Description
Cooling capacity	The cooling air baffle must be designed so, that it transfers thermal energy of approx. 6 kW (5.7 BTU/s) at take-off performance.
Cross section of air baffle	Cross section of the air baffle min. 100 cm ² (15.50 in ²).
Material	Glass fibre reinforced plastic or heat and fire resistant material.
Attachment options	Form-fitting on engine block and mounting above the cylinder and the crankcase.

BRP-Rotax INSTALLATION MANUAL

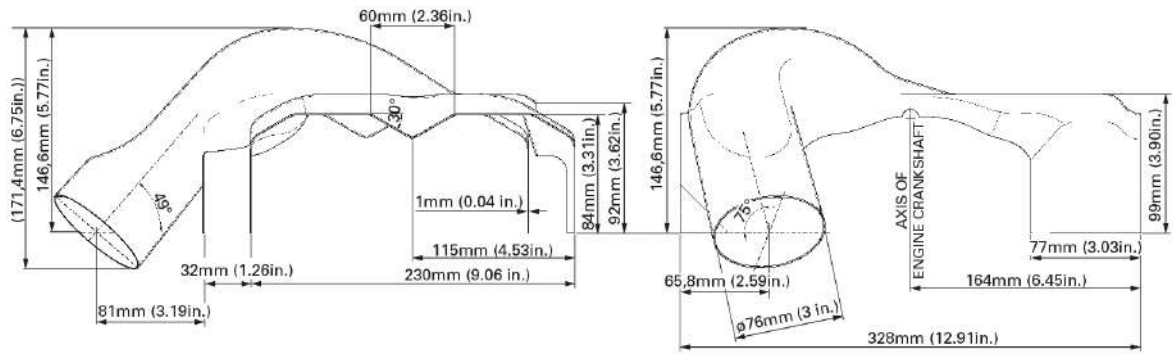

AE 6iS_0348

Figure 8.7: Cooling air baffle for tractor

BRP-Rotax INSTALLATION MANUAL

INSTALLATION NOTES

The representation of components in this chapter which are not within scope of the delivery is only symbolic. The design shown in this chapter does not represent a specified execution but should support the understanding of the system.

The final design, the selection and specification of parts according to the respective applicable regulations, the consideration of the system limitations and interface description as well as the comprehension of the operating limits in every operational state is in the responsibility of the aircraft manufacturer.

The aircraft manufacturer has to make sure that the operating limits given in the Operators Manual (OM) can be supervised by the pilot. The execution of the installation must allow the operation of the engine according to the Operators Manual (OM).

INSTALLATION OVERVIEW

Radiator

In an installation as depicted with the radiator in a higher position than the standard supplied expansion tank, a water accumulator has to be fitted instead of the expansion tank. Additionally a suitable expansion tank has to be installed at the highest point of the cooling circuit

In order to support the deployment of the radiator's full capacity, the radiator should be connected with the upper connection to the suction side in direction to the water pump. Otherwise, air bubbles may accumulate, resulting in reduced cooling capacity (see setup depicted in [Cooling system schematic](#)).

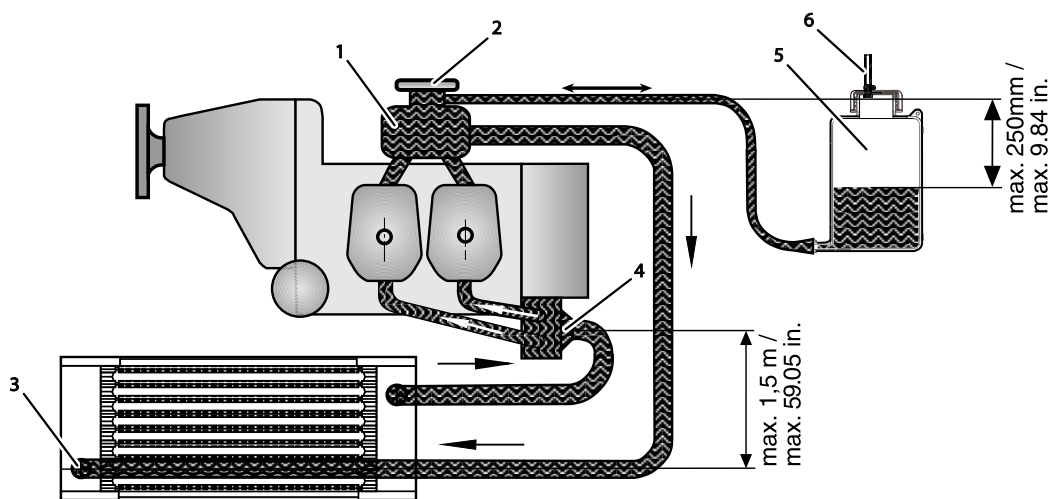

AE_5iS_0884

Figure 8.8: Cooling system schematic

- | | | | |
|---|-----------------|---|--------------|
| 1 | Expansion tank | 2 | Pressure cap |
| 3 | Radiator | 4 | Water pump |
| 5 | Overflow bottle | 6 | Vent |

BRP-Rotax INSTALLATION MANUAL

WATER INLET ELBOW

NOTICE

The hoses should be fixed with appropriate clips to prevent loss e.g. with spring type hose clips, such as those used for the coolant hoses between the water pump and cylinder.

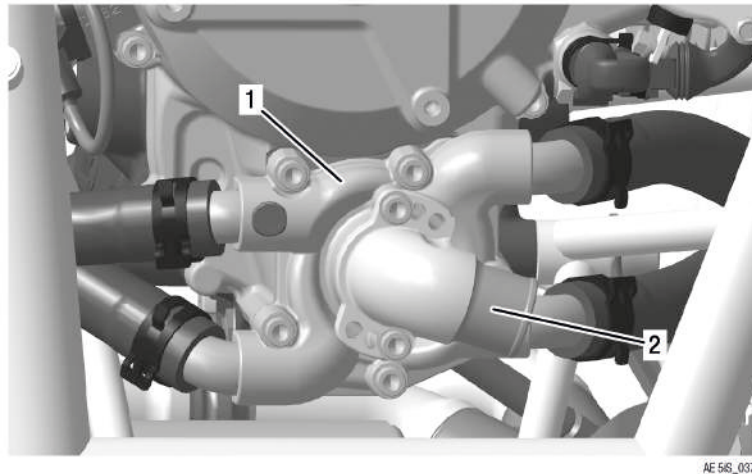

Figure 8.9: Water inlet elbow

1 Water pump housing

2 Water inlet elbow

Use two M6x20 Allen screws lock washers to attach the water inlet elbow. Tighten screws to 10 Nm (90 in lb.)

NOTICE

The total slip-on length of the water inlet elbow and expansion tank should be used.

EXPANSION TANK

The aircraft manufacturer should give the possibility to the pilots to check the coolant level in the expansion tank. It is also necessary to inform the pilots about the daily inspection of the coolant level in the aircraft manufacturers Operators Manual.

To allow this inspection, e.g. a flap or panel on the cowling or a warning instrument in the cockpit for low coolant level should be foreseen.

COOLANT HOSES

NOTE

For proper operation keep hoses as short as possible.

BRP-Rotax INSTALLATION MANUAL

Aluminium tubes with an inner diameter of 25 mm (0.98 in) can be used instead of longer hoses. These should have a bulge (1) in order to prevent coolant hoses working loose. Note as well that this will double the number of hose clamps required. The material of the hoses must be resistant against glycol, coolant and ozone.

Interface Parameter	Min.	Max.
Temperature resistance	125 °C (257 °F)	
Pressure durability	5 bar (72 psi)	
Inner diameter	25 mm (1")	
Bending radius	175 mm (6.89 in)	

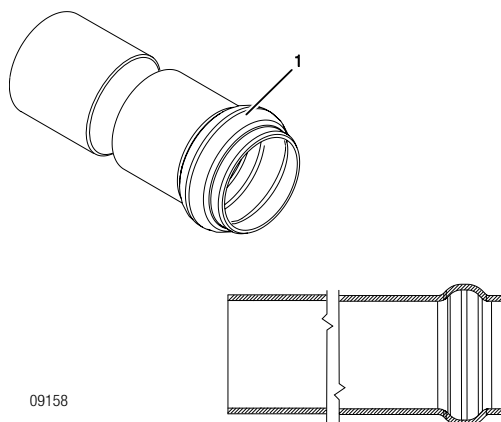

Figure 8.10: Aluminium tube

1 *Bead*

⚠ WARNING

Risk of fire during operation.

Because of the high temperatures, provide suitable protection against accidental contact. Install heat shields in required areas (fuel, oil, coolant hoses or tubes) and/or on the electronic components.

Hoses

Hoses exposed to direct heat radiation from exhaust system must be suitably protected with e.g. heat resistant protection tubes.
The hose between the overflow bottle and the expansion tank should be as short as possible and have a resistance to collapsing under temperature and vacuum.

COOLANT

NOTICE

Use only coolant as recommended in the current Operators Manual (OM) and SI-915 i-001 "Selection of suitable operation fluids", current issue.

BRP-Rotax INSTALLATION MANUAL

VALIDATION OF INSTALLATION

General

The validation procedures described in this chapter do not claim to be complete. The correct execution and compliance with all given system limitations and interface descriptions as well as with standards and norms given by authorities must be proven by the aircraft manufacturer.

Coolant temperature

The maximum coolant temperature must be determined in order to check the efficiency of the cooling system.

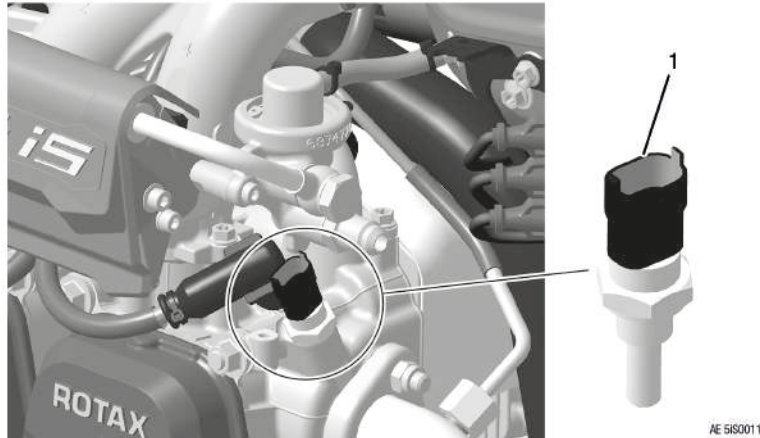

Figure 8.11: Coolant Temperature Sensor (CTS), TYPICAL

1 Coolant temperature sensor

The coolant temperature is measured using a temperature sensor (1), which is installed on cylinder 4.

NOTICE

It is possible to record a false measurement when measuring fluid temperatures. If fluid volume is lost and sensor is not fully submerged in the liquid, the indicating instrument could incorrectly display a lower temperature, by measuring the air temperature instead of the coolant temperature.

Pressure test

To ensure the System has no leakage, remove the pressure cap from the expansion tank. Then attach the pressure tester and pump the system until the pressure manometer shows 1.2 bar (18 psi). After min. 1 minute, there should be still 1.2 bar (18 psi) pressure in the system.

- Check the efficiency of the coolant radiator and its proper sealing between cowling and radiator.
- Check the proper flow between expansion tank and overflow bottle.
- Ensure that no ram-air is induced onto the overflow bottle vent line.
- Check efficiency of air duct and proper air flow through the duct and around cylinders.

BRP-Rotax

INSTALLATION MANUAL

- Consider cold (winter) and hot (summer) conditions in ground and flight testing.
- Check proper dampening of the water radiator and stressfree installation and proper sealing.

BRP-Rotax
INSTALLATION MANUAL

Chapter: 76-00-00
ENGINE CONTROLS

TOPICS IN THIS CHAPTER

Special tools	4
System description	5
System limitations	5
Interface description	6
Interface overview	6
Electrical interfaces	7
Interface overview — 915 I Type C24	10
Electrical interfaces – 915 I Type C24	11
Mechanical interfaces	14
Installation notes	16
Installation overview	16
Installation overview – 915 I Type C24	18
LANE Select Switches	20
Fuel pump switches	20
Start Switch	20

BRP-Rotax INSTALLATION MANUAL

915 i TYPE C24

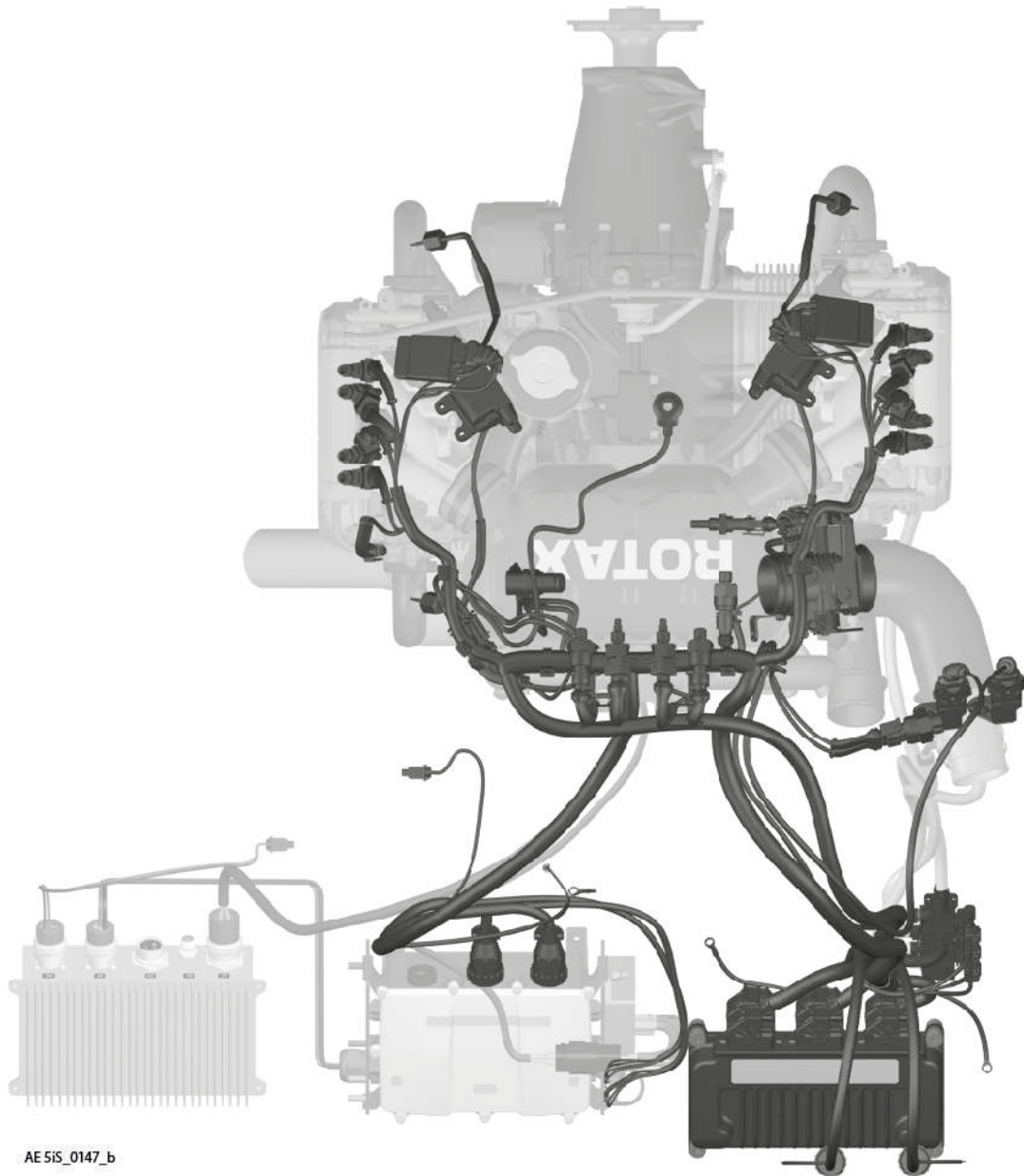

AE 5iS_0147_b

Figure 9.2: Engine management system (EMS)

BRP-Rotax
INSTALLATION MANUAL

SPECIAL TOOLS

Description	Part number
Crimping pliers MOLEX 64016-0035/63811-4400	n.a.
Disassembly tool MOLEX 63813-1500	n.a.
Crimp tool ROTAX® ACDC 28 V X1/X2 and 14 V X1 - SKU: 10-306 ⁴	n.a.
Crimp tool ROTAX® ACDC 28 V X3/X4 - SKU: 10-309 ⁴	n.a.
Crimp tool ROTAX® ACDC 28 V X5 and 14 V X3 - SKU: 10-311 ⁴	n.a.

4. can be ordered under www.rs-flightsystems.com

BRP-Rotax INSTALLATION MANUAL

SYSTEM DESCRIPTION

For a detailed System description refer to the latest issue of the Operators Manual (OM).

SYSTEM LIMITATIONS

Operating limits Refer to latest issue of the Operators Manual (OM).

Valid installation positions The ECU may be installed either in the engine compartment or in the cockpit. To prevent the ingress of liquids (moisture), the ECU must be mounted in a way that the connectors are facing downward.

The two Ambient Air Pressure and Temperature Sensors (AAPTS) are all-in-one sensors for engine ambient temperature and engine ambient pressure. In cowled engine installations they have to be mounted in the engine compartment in a ram air free area and close to the air inlet. The sensors must measure the correct air inlet temperature and the air pressure right before the air filter. The AAPTS sensors must not be mounted in the air intake system between the air filter and turbocharger inlet. The AAPTS need to be mounted isolated from vibrations (e.g. caused by the engine).

The casing of the ECU must not be connected to the airframe ground. The rubber vibration damping (insulation material) must not be removed. If the rubber dampers were removed, the engine ground and the aircraft ground would be short-circuited.

Component temperatures limitation Limitation see Chapter 00-00-00 Approval of electric and electronic components.

Connections When connecting the wiring harness with the ECU take into account the labeling on the wiring harness and the ECU. Although the connectors are mechanically coded (i.e. wiring harness connector A1 can only be connected to ECU A1 socket), excessive force or incorrect positioning can result in bent pins and the ECU would then need to be replaced. Unplug the ECU connector from the wiring harness only if absolutely necessary. Connector plugs (ECU) are suitable for up to 20 plug-in operations. The number of plugging operations must be entered into the logbook. If this limit has been exceeded the ECU needs to be replaced.

Wiring harness The wiring harness must NOT be shortened or modified. Do not bend, kink, pinch or otherwise improperly stress the wiring harness. The bending radius of the wiring harness must not be less than 50 mm (1.97 in). To avoid excessive tension on the ECU connectors, a strain relief must be installed in a distance of ~ 100 mm (3.94 in) from the ECU.

NOTICE

Do not bend, kink, pinch or otherwise improperly stress the wiring harness. Use proper routing, clamping and strain relief on wiring harnesses.

BRP-Rotax
INSTALLATION MANUAL

INTERFACE DESCRIPTION

INTERFACE OVERVIEW

915 i TYPE A

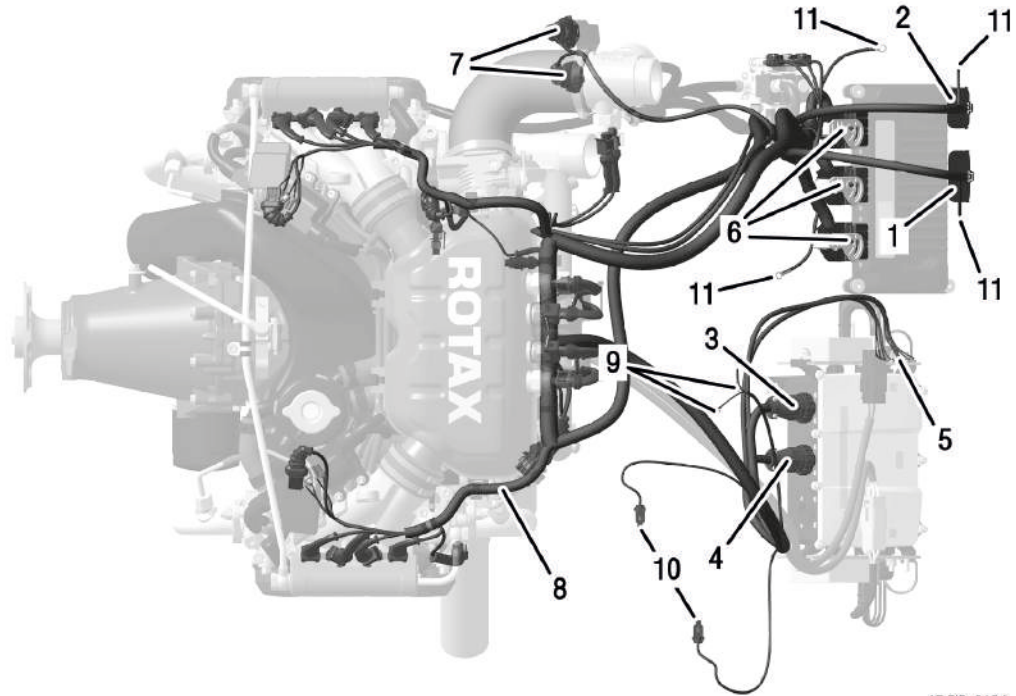

AE 5IS_0184

Figure 9.3: Engine Management System (EMS)– Interfaces

- | | | | |
|----|---|----|---|
| 1 | <i>Harness Interface Connector A (HIC A) (electrical Interface)</i> | 2 | <i>Harness Interface Connector B (HIC B) (electrical Interface)</i> |
| 3 | <i>X1 Connector (electrical Interface)</i> | 4 | <i>X2 Connector (electrical Interface)</i> |
| 5 | <i>Regulator A (electrical Interface)</i> | 6 | <i>ECU (electrical, mechanical Interface)</i> |
| 7 | <i>AAPTS (electrical, mechanical Interface)</i> | 8 | <i>Wiring harness</i> |
| 9 | <i>Starter relay connectors (electrical Interface)</i> | 10 | <i>Fuel pump connectors (electrical Interfaces)</i> |
| 11 | <i>Wiring harness grounding</i> | | |

BRP-Rotax INSTALLATION MANUAL

ELECTRICAL INTERFACES

Harness interface connector A The HIC A connector allows powering ECU Lane A and Fuel Pump A. interfaces to Indication elements are described in Chapter 77-00-00.

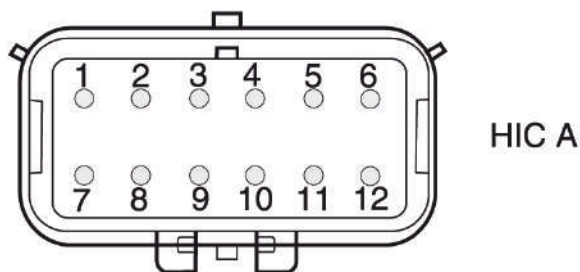

AE 5iS_0186

Figure 9.4: HIC A Connector

In case the EMS is powered by an external power source or by one of the internal generators:

- A connection between Terminal 1 and Terminal 7 will power ECU Lane A
- A connection between Terminal 3 and Terminal 9 will power Fuel pump 1

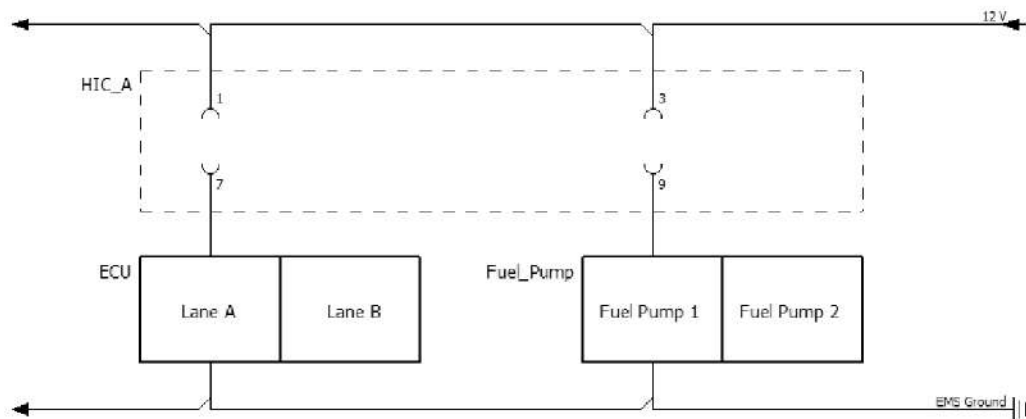

AE 5iS_0188

Figure 9.5: HIC A connector –Engine controls

BRP-Rotax INSTALLATION MANUAL

Terminal (Supply)		Terminal (Ground)		Interface Parameter	Min.	Max.	Nominal
1	LANE_SEL_SW_A_1	7	LANE_SEL_SW_A_2	Nominal Voltage			12 V
				Nominal Current		7.5 A	
3	SIG_FUEL_PUMP_1	9	GND_FUEL_PUMP_1	Nominal Voltage			12 V
				Nominal Current		10 A	

Harness Interface Connector B

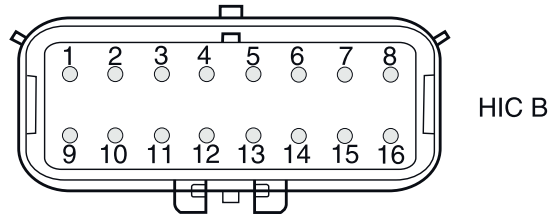

AE 5IS_0187

Figure 9.6: HIC B connector

In case the EMS is powered by an external power source or by one of the internal generators:

- A connection between Terminal 1 and Terminal 9 will power ECU Lane B
- A connection between Terminal 3 and Terminal 11 will power Fuel Pump 2
- A connection between Terminal 4 and Terminal 12 will actuate the Starter Relay

BRP-Rotax INSTALLATION MANUAL

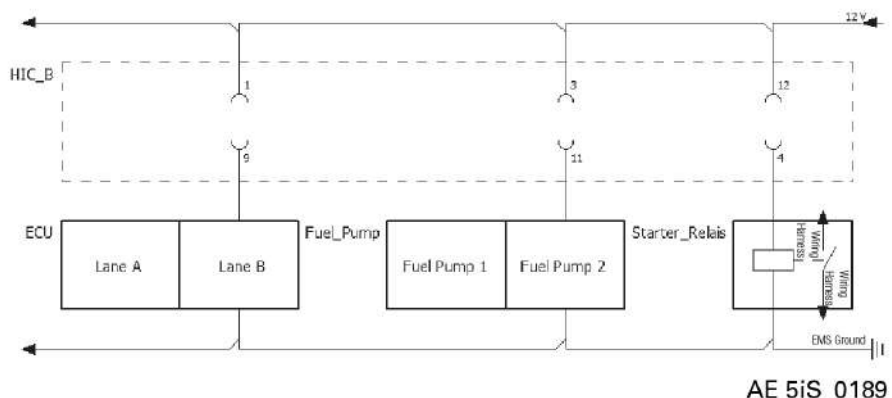

Figure 9.7: HIC B Connector – Engine controls

Terminal (Supply)		Terminal (Ground)		Interface Parameter	Min.	Max.	Nominal
1	LANE_SEL_SW_B_1	9	LANE_SEL_SW_B_2	Nominal Voltage			12 V
				Nominal Current		7.5 A	
3	SIG_FUEL_PUMP_2	11	GND_FUEL_PUMP_2	Nominal Voltage			12 V
				Nominal Current		10 A	
12	SUPP_START_SWITCH	4	CONN_STARTER_REL_SW	Nominal Voltage			12 V
				Nominal Current		5 A	

The HIC B connector allows powering ECU Lane B. Interfaces to indication elements are described in Chapter 77-00-00.

X1, X2 Connector [See Chapter 24-00-00 section Interface Description.](#)

Regulator A [See Chapter 24-00-00 section 24-00-00 section Interface Description.](#)

Starter Relay [See Chapter 80-00-00 section Interface Description](#)

Wiring harness grounding The grounding cable must be attached to Fusebox Regulator A. [See Chapter 24-00-00 section Fusebox Regulator A](#)

Fuel pump [See Chapter 73-00-00 section Interface Description](#)

BRP-Rotax
INSTALLATION MANUAL

INTERFACE OVERVIEW — 915 i TYPE C24

915 i TYPE C24

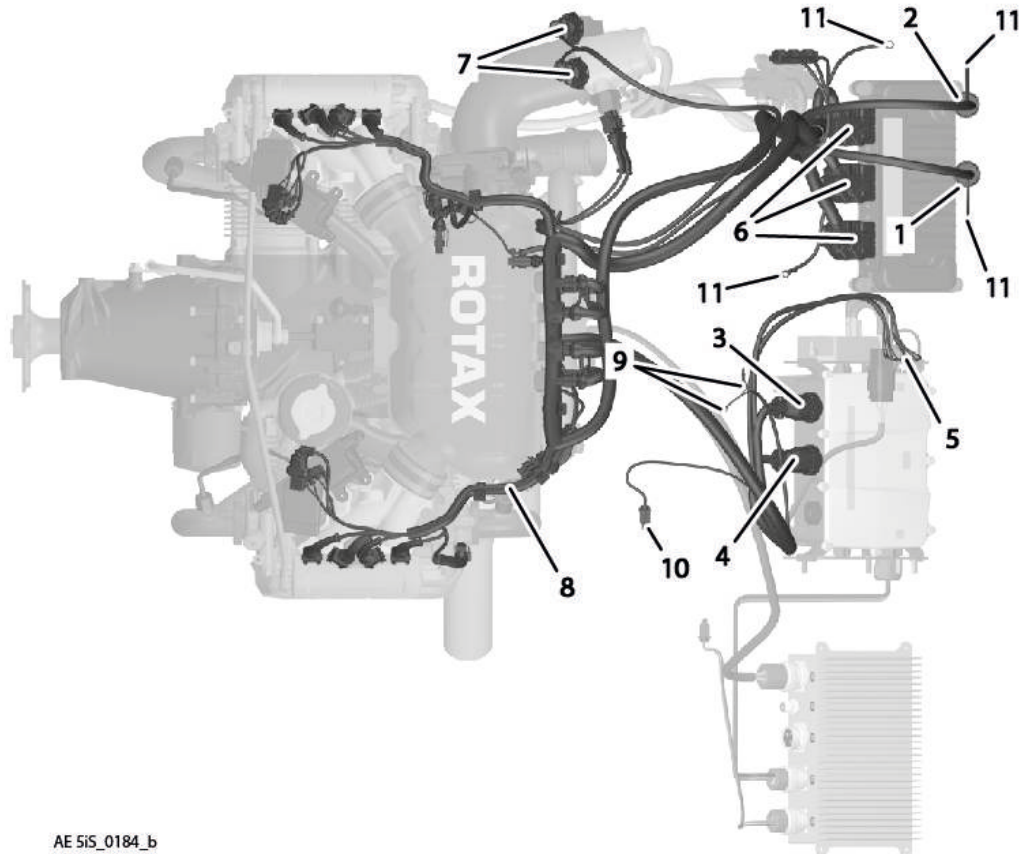

AE 5iS_0184_b

Figure 9.8: Engine Management System (EMS)– Interfaces

- | | | | |
|----|---|----|---|
| 1 | <i>Harness Interface Connector A (HIC A)
(electrical Interface)</i> | 2 | <i>Harness Interface Connector B (HIC B)
(electrical Interface)</i> |
| 3 | <i>X1 Connector (electrical Interface)</i> | 4 | <i>X2 Connector (electrical Interface)</i> |
| 5 | <i>Regulator A (electrical Interface)</i> | 6 | <i>ECU (electrical, mechanical Interface)</i> |
| 7 | <i>AAPTS (electrical, mechanical
Interface)</i> | 8 | <i>Wiring harness</i> |
| 9 | <i>Starter relay connectors (electrical
Interface)</i> | 10 | <i>Fuel pump connectors (electrical
Interfaces)</i> |
| 11 | <i>Wiring harness grounding</i> | | |

BRP-Rotax INSTALLATION MANUAL

ELECTRICAL INTERFACES – 915 i TYPE C24

Harness interface connector A 915 i TYPE C24

The HIC A connector allows powering ECU Lane A and Fuel Pump A. interfaces to Indication elements are described in Chapter 77-00-00.

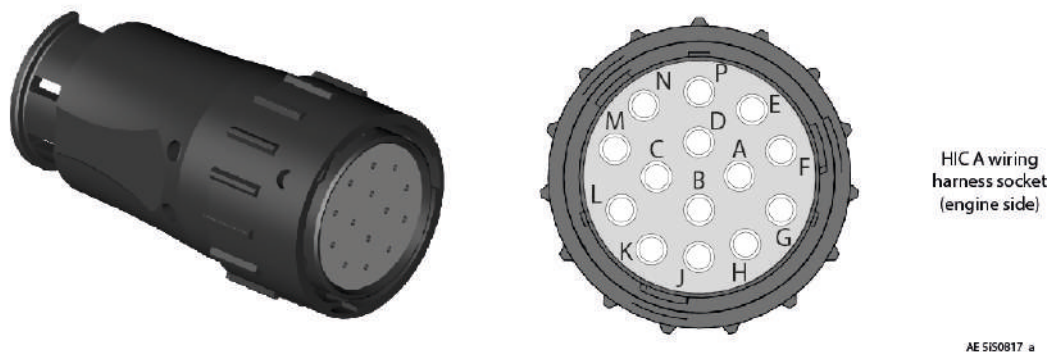
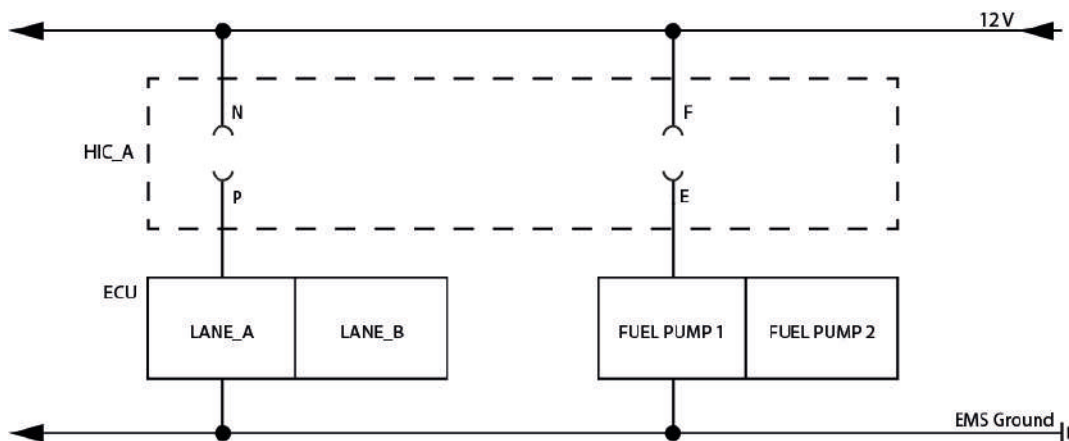

Figure 9.9: HIC A Connector

In case the EMS is powered by an external power source or by one of the internal generators:

- A connection between Terminal N and Terminal P will power ECU Lane A



AE 5IS0023_a

Figure 9.10: HIC A connector –Engine controls

BRP-Rotax INSTALLATION MANUAL

Terminal (Supply)		Terminal (Ground)		Interface Parameter	Min.	Max.	Nominal
N	LANE_SEL_SW_A_1	P	LANE_SEL_SW_A_2	Nominal Voltage			12 V
				Nominal Current		7.5 A	
F	SIG_FUEL_PUMP_1	E	GND_FUEL_PUMP_1	Nominal Voltage			12 V
				Nominal Current		10 A	

Harness Interface Connector B

915 i TYPE C24

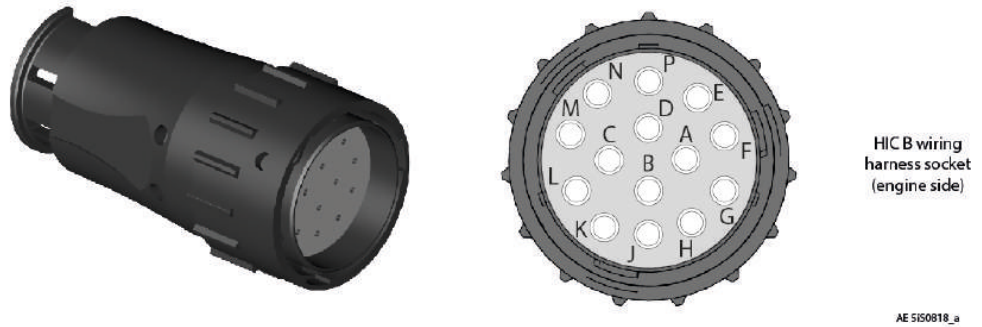
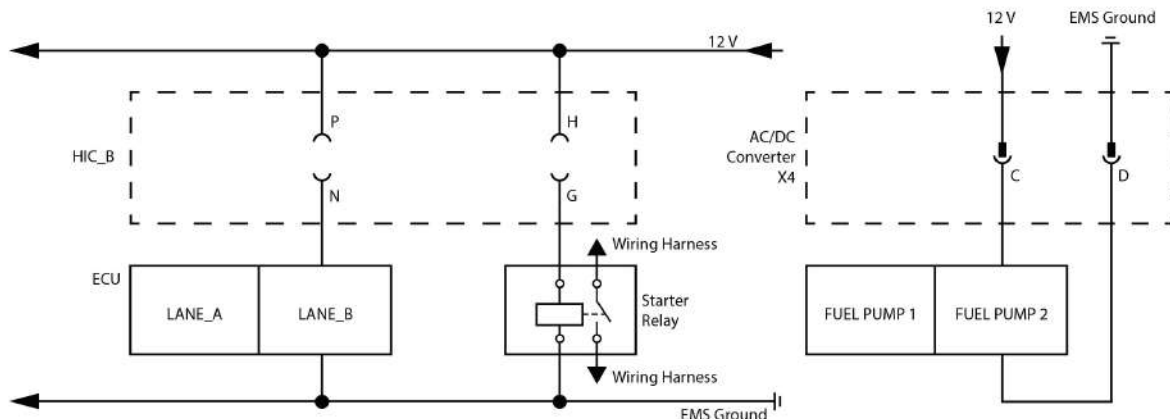

Figure 9.11: HIC B connector

In case the EMS is powered by an external power source or by one of the internal generators:

- A connection between Terminal N and Terminal P will power ECU Lane B

BRP-Rotax INSTALLATION MANUAL



AE 51S0022_a

Figure 9.12: HIC B Connector – Engine controls

Terminal (Supply)		Terminal (Ground)		Interface Parameter	Min.	Max.	Nominal
P	LANE_SEL_SW_B_1	N	LANE_SEL_SW_B_2	Nominal Voltage			12 V
				Nominal Current		7.5 A	
F	SUPP_START_SWITCH	E	CONN_START-ER_REL_SW	Nominal Voltage			12 V
				Nominal Current		5 A	
C	SIG_FUEL_PUMP_2	D	GND_FUEL_PUMP_2	Nominal Voltage			12 V
				Nominal Current		10 A	

The HIC B connector allows powering ECU Lane B. Interfaces to indication elements are described in Chapter 77-00-00.

X1, X2 Connector [See Chapter 24-00-00 section Interface Description.](#)

Regulator A [See Chapter 24-00-00 section 24-00-00 section Interface Description.](#)

Wiring harness grounding The grounding cable must be attached to Fusebox Regulator A. [See Chapter 24-00-00 section Fusebox Regulator A](#)

BRP-Rotax INSTALLATION MANUAL

MECHANICAL INTERFACES

Engine Control
Unit (ECU)

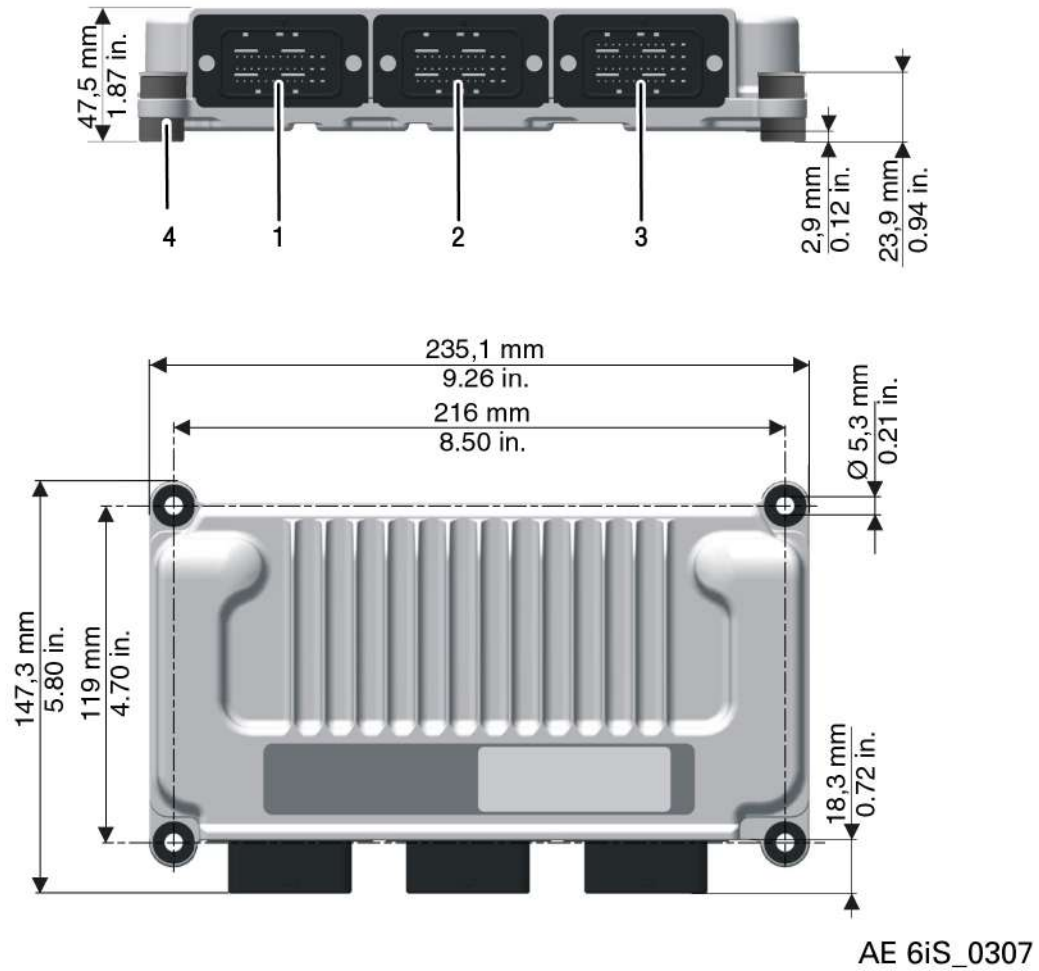

Figure 9.13: ECU –mounting points

- | | |
|-----------------------|-----------------------|
| 1 Connector socket A1 | 2 Connector socket A2 |
| 3 Connector socket B | 4 Rubber sleeve |

BRP-Rotax INSTALLATION MANUAL

Sensors

Ambient Air Pressure and Temperature Sensors (AAPT 1, 2)

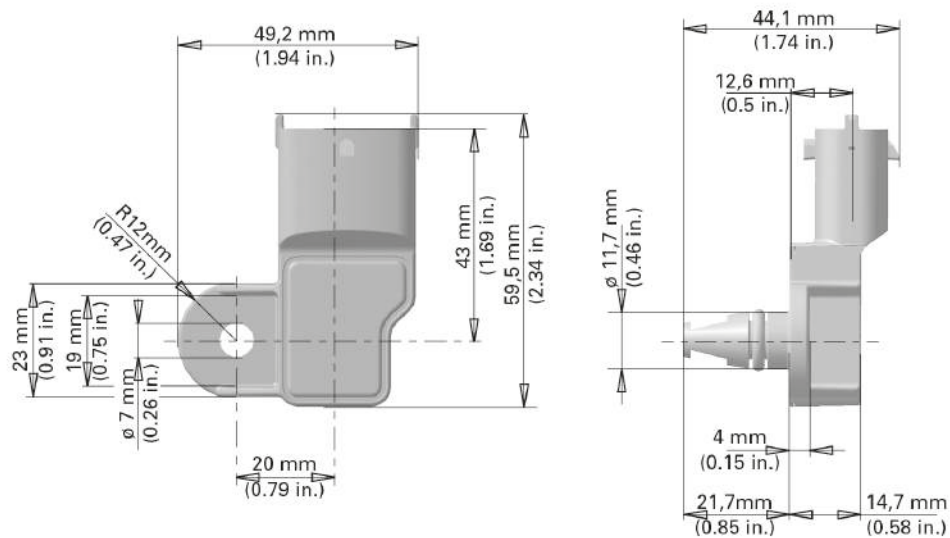

AE 5IS_0017

Figure 9.14: AAPT – mounting points

Maximum diameter of fastener in the interior of the mounting hole: 6 mm (0.24 in.). Only mount sensor with a washer (\varnothing 10 mm (0.39 in.) or with an adequate fastener head diameter. The maximum permissible pressure at the mounting flange may not exceed 20 N/mm² (0.0029 psi).

BRP-Rotax INSTALLATION MANUAL

INSTALLATION NOTES

General

The representation of components in this chapter which are not within scope of the delivery is only symbolic. The design shown in this chapter does not represent a specified execution but should support the understanding of the system.

The final design, the selection and specification of parts according to the respective applicable regulations, the consideration of the system limitations and interface description as well as the comprehension of the operating limits in every operational state is in the responsibility of the aircraft manufacturer.

The aircraft manufacturer has to make sure that the operating limits given in the Operators Manual (OM) can be supervised by the pilot. The execution of the installation must allow the operation of the engine according to the Operators Manual (OM).

INSTALLATION OVERVIEW

915 i TYPE A

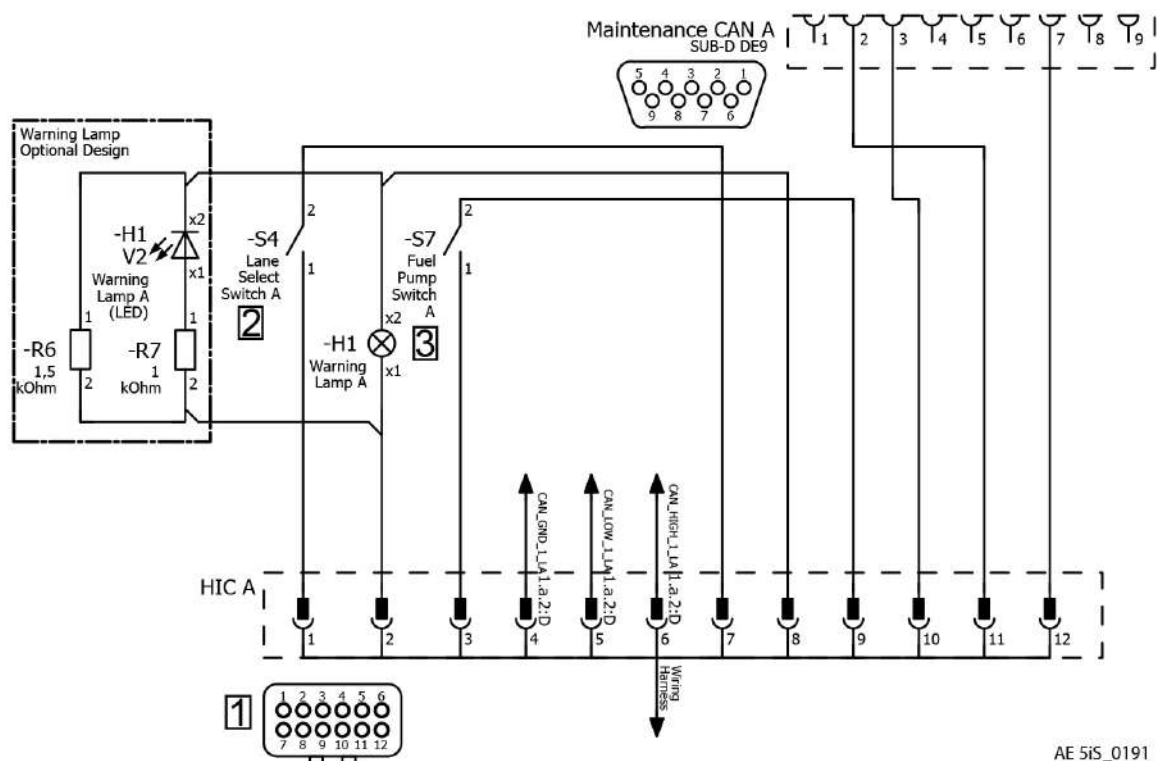

AE 5iS_0191

Figure 9.15: Harness Interface Connector A-Schematic

Part	Function
1	Harness Interface Connector A
2	Lane Select Switch A (-S4)
3	Fuel Pump Switch A (-S7)

BRP-Rotax INSTALLATION MANUAL

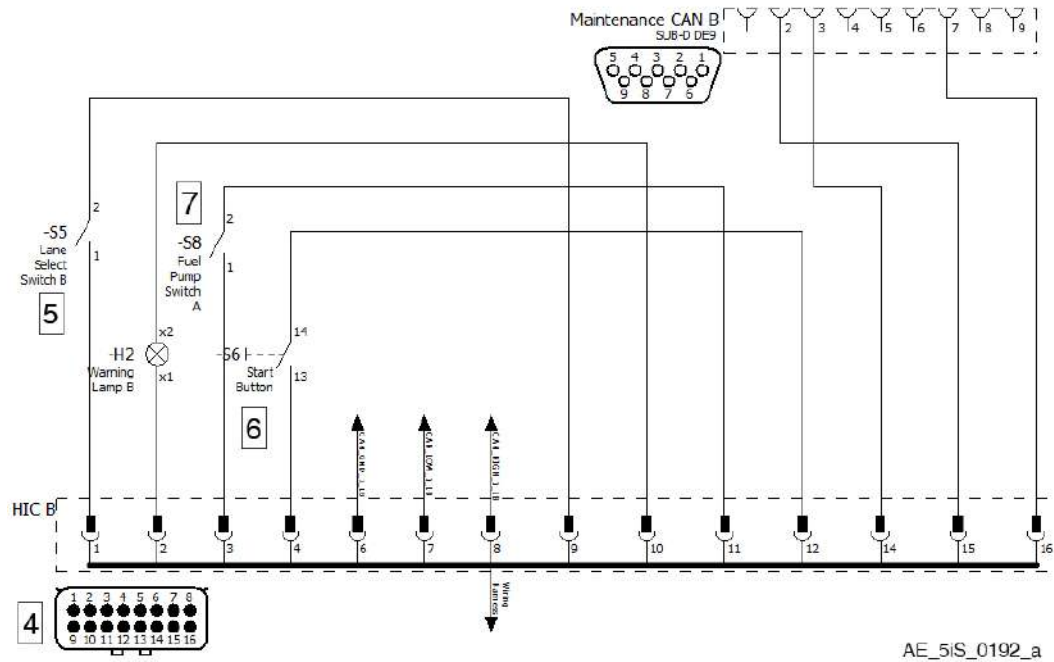

AE_5iS_0192_a

Figure 9.16: Harness Interface Connector B-Schematic

Part	Function
4	Harness Interface Connector B
5	Lane Select Switch B (-S5)
6	Start Switch (-S6)
7	Fuel Pump Switch A (-S8)

BRP-Rotax INSTALLATION MANUAL

INSTALLATION OVERVIEW – 915 I TYPE C24

915 i TYPE C24

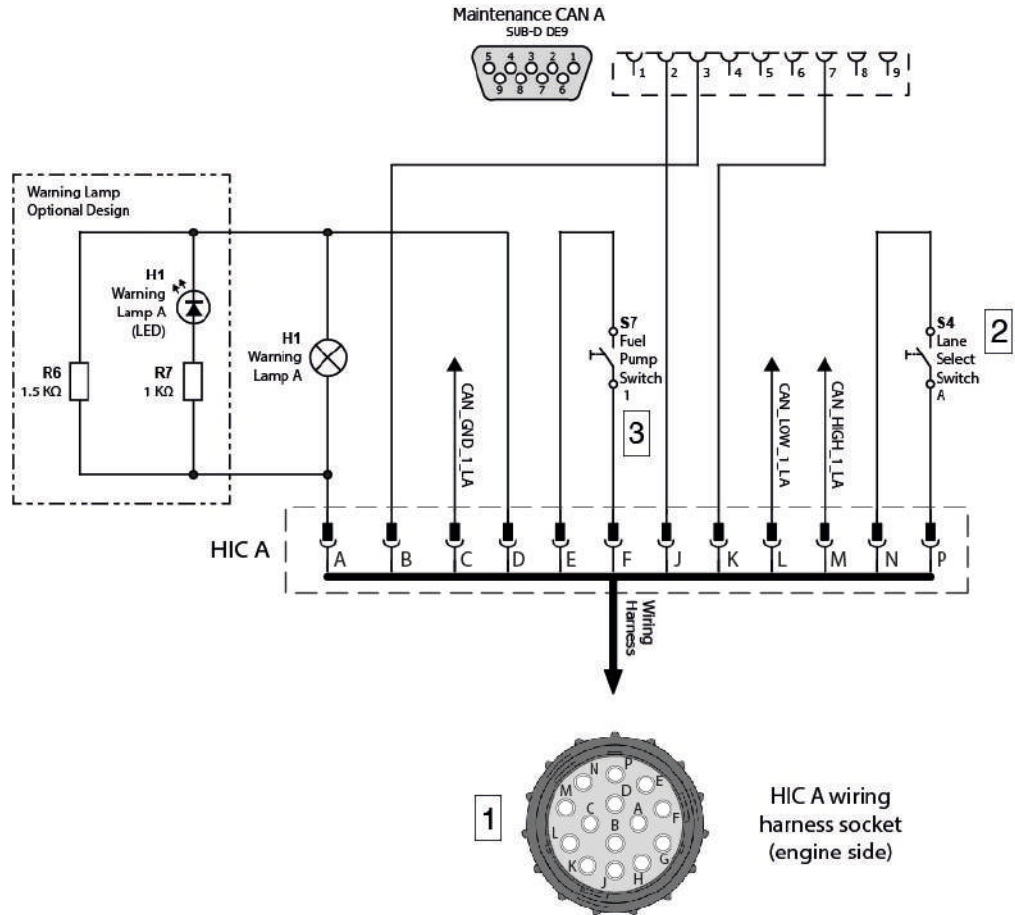

AE 515_0021_b

Figure 9.17: Harness Interface Connector A-Schematic

Part	Function
1	Harness Interface Connector A
2	Lane Select Switch A (-S4)
3	Fuel Pump Switch 1 (-S7)

BRP-Rotax INSTALLATION MANUAL

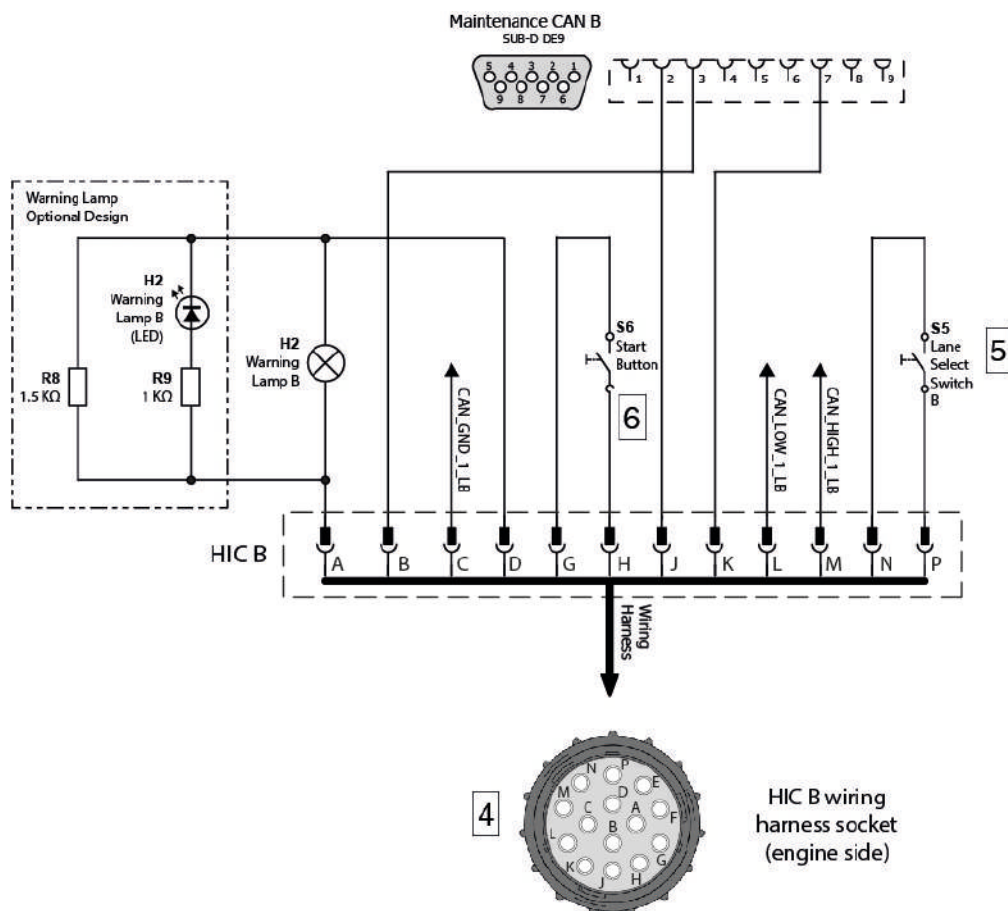

AE 5iS_0020_b

Figure 9.18: Harness Interface Connector B-Schematic

Part	Function
4	Harness Interface Connector B
5	Lane Select Switch B (-S5)
6	Start Switch (-S6)

BRP-Rotax

INSTALLATION MANUAL

LANE SELECT SWITCHES

Lane Select Switch A (-S4)

Interface Parameter	Value
Switch type	Toggle (normally open)
Nominal voltage	28 V
Nominal current	7.5 A
Number of poles	1-pole

Lane Select Switch B (-S5)

Interface Parameter	Value
Switch type	Toggle (normally open)
Nominal voltage	28 V
Nominal current	7.5 A
Number of poles	1-pole

FUEL PUMP SWITCHES

Fuel pump Switch 1 (-S7)

Interface Parameter	Value
Switch type	Toggle (normally open)
Nominal voltage	28 V
Nominal current	10 A
Number of poles	1-pole

Fuel Pump Switch 2 (-S7)

Interface Parameter	Value
Switch type	Toggle (normally open)
Nominal voltage	28 V
Nominal current	10 A
Number of poles	1-pole

START SWITCH

Start Switch (-S6)

Interface Parameter	Value
Switch type	Button (normally open, non-locking)
Nominal voltage	28 V
Nominal current	5 A
Number of poles	1-pole

BRP-Rotax
INSTALLATION MANUAL

Chapter: 77-00-00
ENGINE INDICATING

TOPICS IN THIS CHAPTER

System description	4
System limitations	4
Interface description	5
Interface overview	5
Electrical interfaces	5
Interface overview – 915 I Type C24	9
Electrical interfaces – 915 I Type C24	10
Installation notes	13
Installation overview	13
Warning lamps	15
CAN interfaces	15
Installation overview – 915 I Type C24	16
Warning lamps – 915 I Type C24	19
CAN interfaces – 915 I Type C24	19

BRP-Rotax
INSTALLATION MANUAL

915 i TYPE A

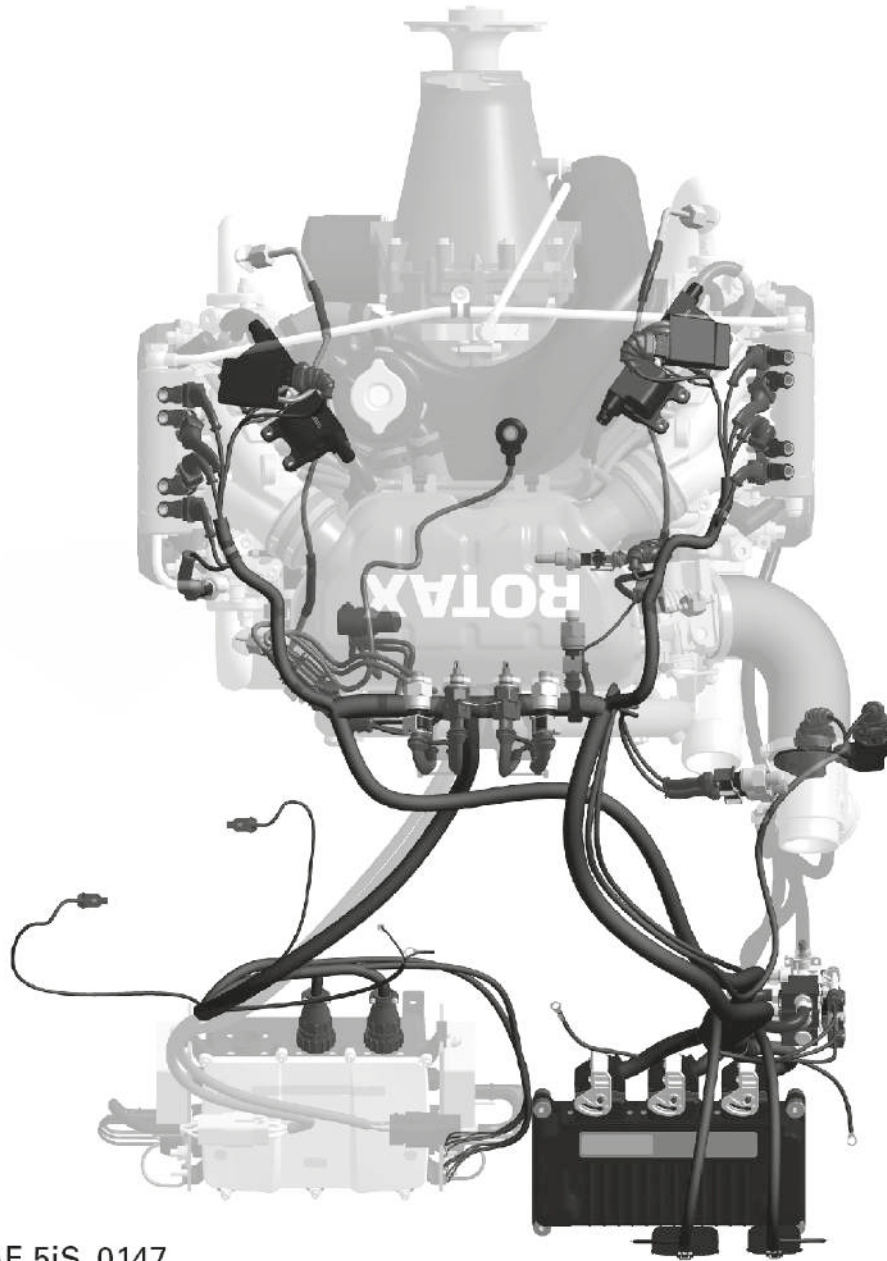

AE 5iS_0147

Figure 10.1: Engine indication, TYPICAL

BRP-Rotax INSTALLATION MANUAL

915 i TYPE C 24

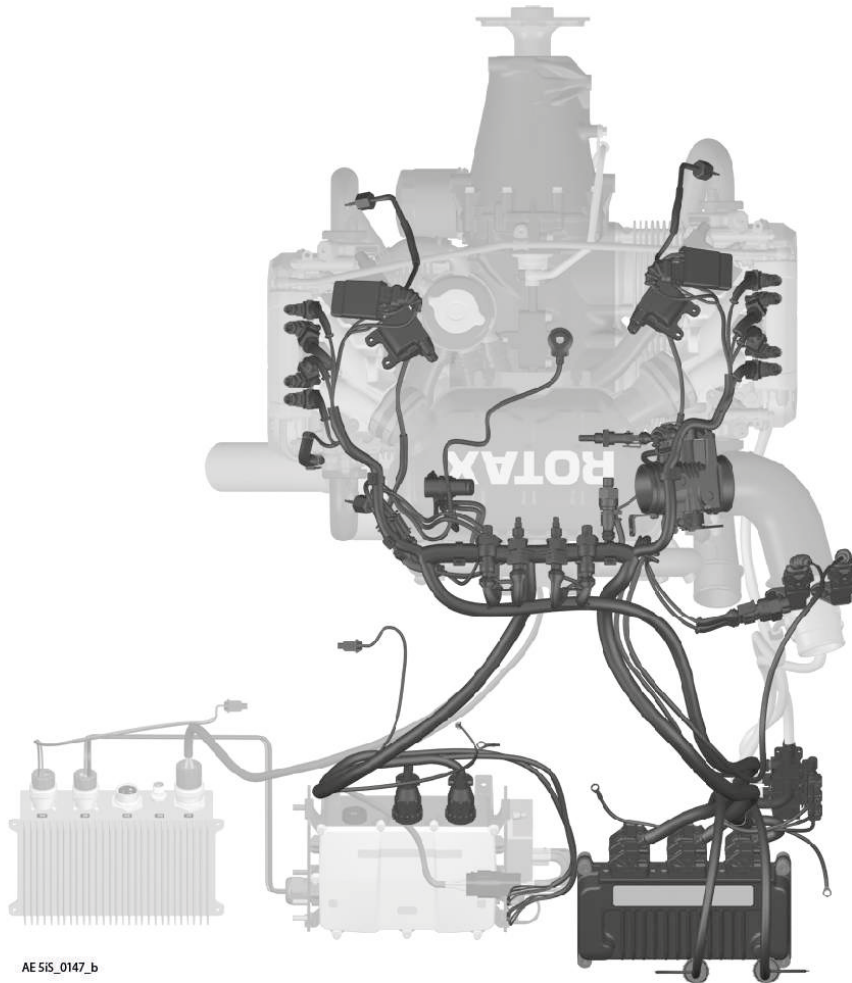

AE 515_0147_b

Figure 10.2: Engine indication

BRP-Rotax INSTALLATION MANUAL

SYSTEM DESCRIPTION

The complete system is volume of supply and is certified together with the engine. For a detailed system description refer to latest issue of the Operators Manual (OM).

SYSTEM LIMITATIONS

Maintenance CAN The Maintenance CAN must only be used in combination with a B.U.D.S. Aircraft USB-to-CAN converter and *B.U.D.S. Aircraft Software*. It is not possible to use the Maintenance CAN for other displaying or data logging purposes.

CAN wiring For the Display- and the Maintenance CAN twisted and shielded cables (3 pins: CAN_H, CAN_L, CAN_GND) must be used for the CAN-connections to ensure a high electromagnetic compatibility in data transmission.

BRP-Rotax
INSTALLATION MANUAL

INTERFACE DESCRIPTION

INTERFACE OVERVIEW

915 i TYPE A

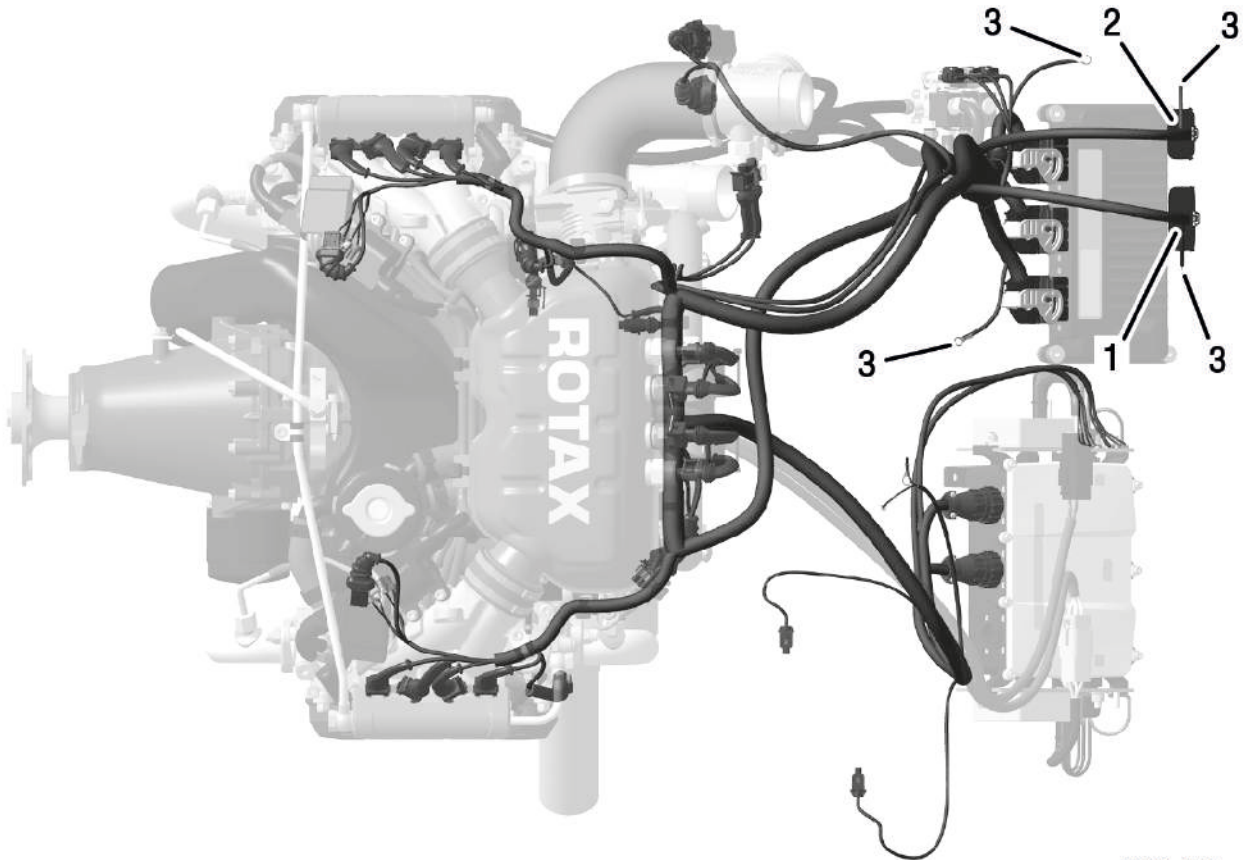

AE 5IS_0184a

Figure 10.3: Engine Management System (EMS) – Interfaces, TYPICAL

- 1 *Harness Interface Connector A (HIC A)*
- 2 *Harness Interface Connector B (HIC B)*
- 3 *Electromagnetic shielding of CAN Bus*

ELECTRICAL INTERFACES

Harness Interface Connector A

The HIC Connector A is equipped with a Maintenance CAN interface, a Display CAN interface and terminals which can be used to actuate a warning lamp indicating the current status of the ECU Lane A. Interfaces to control elements are described in Chapter 76-00-00.

BRP-Rotax INSTALLATION MANUAL

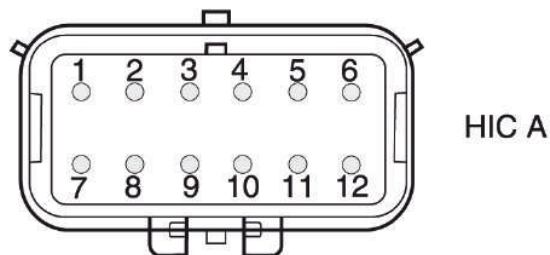

AE 5IS_0186

Figure 10.4: HIC A Connector

Warning Lamp

Terminal (Supply)	Terminal (Ground)	Interface Parameter	Min.	Max.	Nominal
2 SUPP_WARN_LAMP_A	8 WARN_LAMP_A	Nominal voltage			12 V
		Nominal current		120 mA	

CAN Interfaces

Terminal	Specification
4 CAN_GND_1_A	Display CAN Lane A
5 CAN_LOW_1_A	
6 CAN_HIGH_1_A	
10 CAN_GND_2_A	Maintenance CAN Lane A
11 CAN_LOW_2_A	
12 CAN_HIGH_2_A	

Connector: HIC Connector A (included in the engines scope of delivery).

The HIC Connectors must be mounted according to the procedure prescribed in Chapter 76-00-00.

The Display CAN is based on the CAN Aerospace protocol. For detailed interface description contact an authorized ROTAX® Distributor or its independent Service Center.

Harness Interface Connector B

The HIC Connector B is equipped with a Maintenance CAN interface, a Display CAN interface and terminals which can be used to actuate a warning lamp indicating the current status of the ECU Lane B. Interfaces to control elements are described in Chapter 76-00-00.

BRP-Rotax INSTALLATION MANUAL

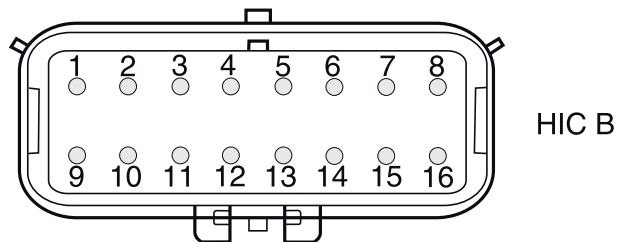

AE 5iS_0187

Figure 10.5: HIC B connector

Warning Lamp

Terminal (Supply)		Terminal (Ground)		Interface Parameter	Min.	Max.	Nominal
2	SUPP_WARN_LAMP_B	10	WARN_LAMP_B	Nominal voltage			12 V
				Nominal current		120 mA	

CAN Interfaces

Terminal		Specification
6	CAN_GND_1_B	Display CAN Lane B
7	CAN_LOW_1_B	
8	CAN_HIGH_1_B	
14	CAN_GND_2_B	Maintenance CAN Lane B
15	CAN_LOW_2_B	
16	CAN_HIGH_2_B	

Terminal (Supply)		Terminal (Ground)		Interface Parameter	Min.	Max.	Nominal
2	SUPP_WARN_LAMP_B	10	WARN_LAMP_B	Nominal voltage			12 V
				Nominal current		120 mA	

Connector: HIC Connector B (included in the engine's scope of delivery).
The HIC Connectors must be mounted according to the procedure prescribed in Chapter 76-00-00.

BRP-Rotax INSTALLATION MANUAL

The Display CAN is based on the CAN Aerospace protocol. For detailed interface description contact an authorized ROTAX® Distributor or its independent Service Center.

Electromagnetic shielding of CAN Bus

The electromagnetic CAN Bus shielding ring terminals need to be connected with the Airframe Ground.

Connector: Ring Terminal M6

BRP-Rotax INSTALLATION MANUAL

INTERFACE OVERVIEW – 915 I TYPE C24

915 i TYPE C 24

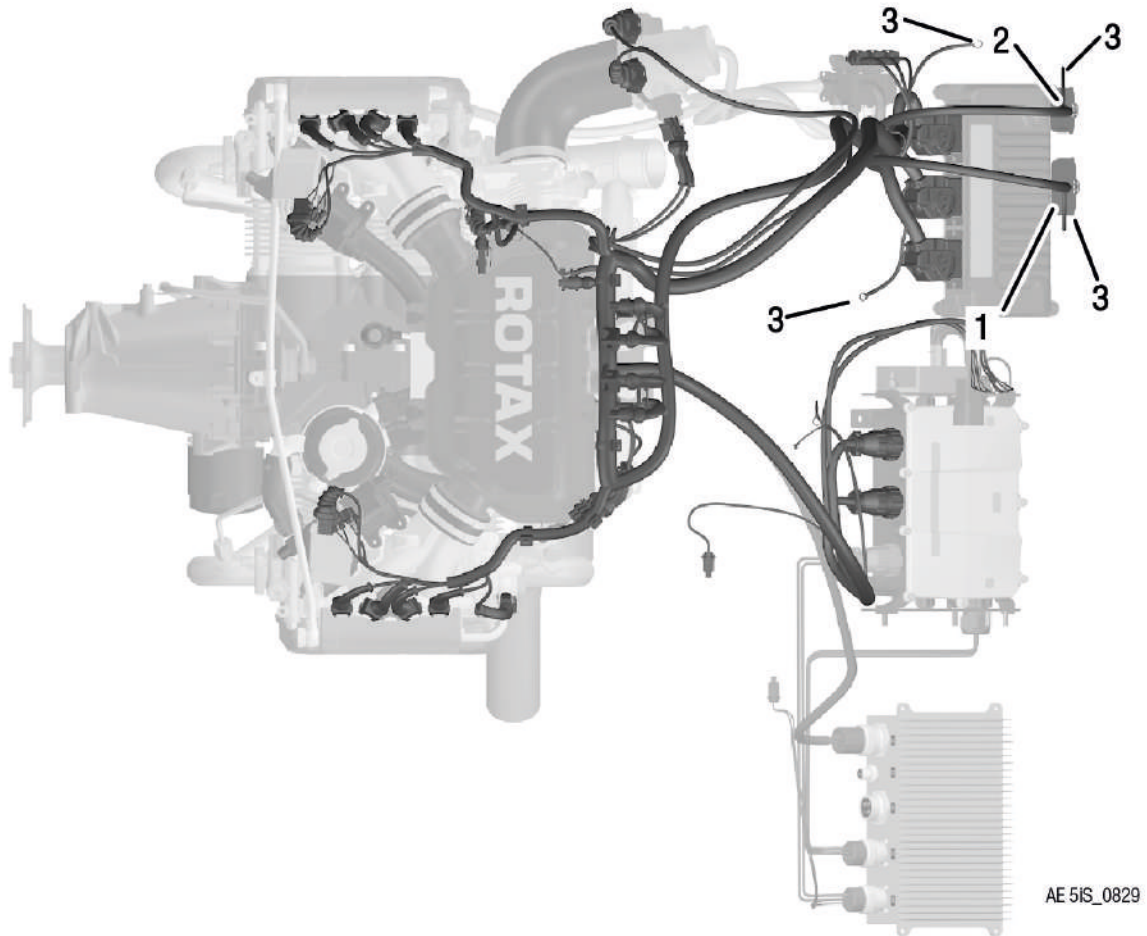

Figure 10.6: Engine Management System (EMS) – Interfaces

- 1 *Harness Interface Connector A (HIC A)*
- 2 *Harness Interface Connector B (HIC B)*
- 3 *Electromagnetic shielding of CAN Bus*

BRP-Rotax INSTALLATION MANUAL

ELECTRICAL INTERFACES – 915 i TYPE C24

Harness Interface Connector A The HIC Connector A is equipped with a Maintenance CAN interface, a Display CAN interface and terminals which can be used to actuate a warning lamp indicating the current status of the ECU Lane A. Interfaces to control elements are described in Chapter 76-00-00.

915 i TYPE C 24

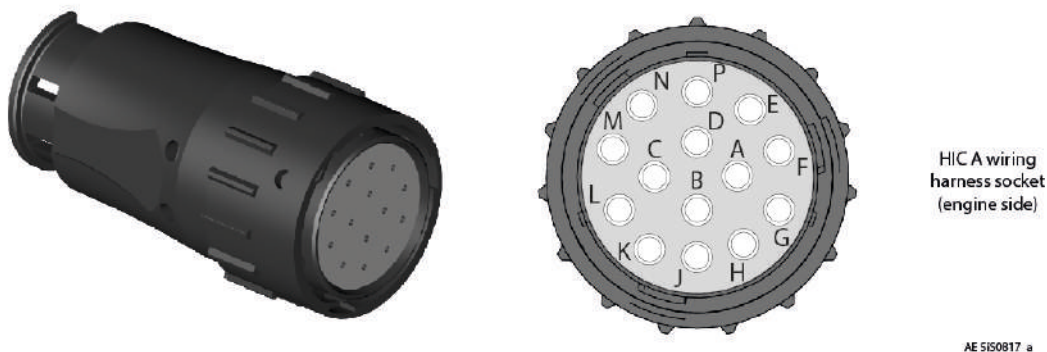

Figure 10.7: HIC A connector

Warning lamp

	Terminal (Supply)	Terminal (Ground)	Interface Parameter	Min.	Max.	Nominal
A	SUPP_WARN_LAMP_A	D	WARN_LAMP_A	Nominal voltage		12 V
				Nominal current		120 mA

CAN Interfaces:

Terminal	Terminal	Specification
C	CAN_GND_1_A	Display CAN Lane A
L	CAN_LOW_1_A	
M	CAN_HIGH_1_A	
B	CAN_GND_2_A	Maintenance CAN Lane A
J	CAN_LOW_2_A	
K	CAN_HIGH_2_A	

Connector: HIC Connector A (included in the engines scope of delivery).
The HIC Connectors must be mounted according to the procedure prescribed in Chapter 76-00-00.

BRP-Rotax INSTALLATION MANUAL

The Display CAN is based on the CAN Aerospace protocol. For detailed interface description contact an authorized ROTAX® Distributor or its independent Service Center.

Harness Interface Connector B

The HIC Connector B is equipped with a Maintenance CAN interface, a Display CAN interface and terminals which can be used to actuate a warning lamp indicating the current status of the ECU Lane B. Interfaces to control elements are described in Chapter 76-00-00.

915 i TYPE C 24

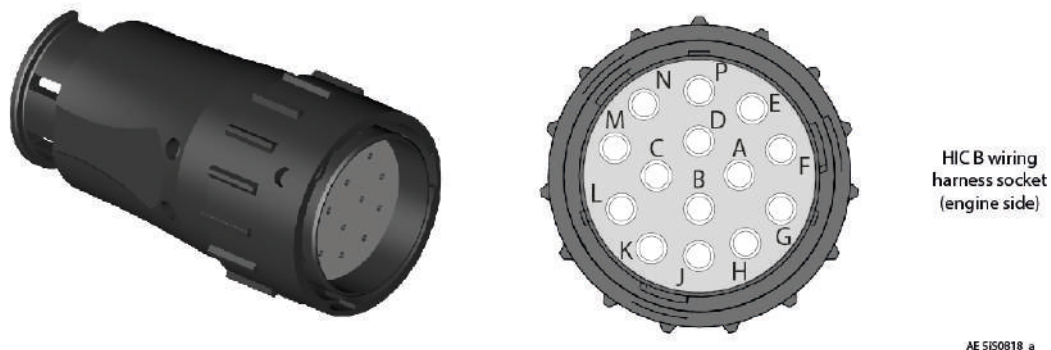

Figure 10.8: HIC B Connector

Warning lamp

Terminal (Supply)		Terminal (Ground)		Interface Parameter	Min.	Max.	Nominal
A	SUPP_WARN_LAMPE_B	D	WARN_LAMP_B	Nominal voltage			12 V
				Nominal current		120 mA	

CAN Interfaces

Terminal	Terminal	Specification
C	CAN_GND_1_B	Display CAN Lane B
L	CAN_LOW_1_B	
M	CAN_HIGH_1_B	
B	CAN_GND_2_B	Maintenance CAN Lane B
J	CAN_LOW_2_B	
K	CAN_HIGH_2_B	

Connector: HIC Connector B (included in the engine's scope of delivery).

The HIC Connectors must be mounted according to the procedure prescribed in Chapter 76-00-00.

BRP-Rotax INSTALLATION MANUAL

The Display CAN is based on the CAN Aerospace protocol. For detailed interface description contact an authorized ROTAX® Distributor or its independent Service Center.

Electromagnetic shielding of CAN Bus

The electromagnetic CAN Bus shielding ring terminals need to be connected with the Airframe Ground.

Connector: Ring Terminal M6

BRP-Rotax INSTALLATION MANUAL

INSTALLATION NOTES

General

The representation of components in this chapter which are not within scope of the delivery is only symbolic. The design shown in this chapter does not represent a specified execution but should support the understanding of the system.

The final design, the selection and specification of parts according to the respective applicable regulations, the consideration of the system limitations and interface description as well as the comprehension of the operating limits in every operational state is in the responsibility of the aircraft manufacturer.

The aircraft manufacturer has to make sure that the operating limits given in the Operators Manual (OM) can be supervised by the pilot. The execution of the installation must allow the operation of the engine according to the Operators Manual (OM).

INSTALLATION OVERVIEW

915 i TYPE A

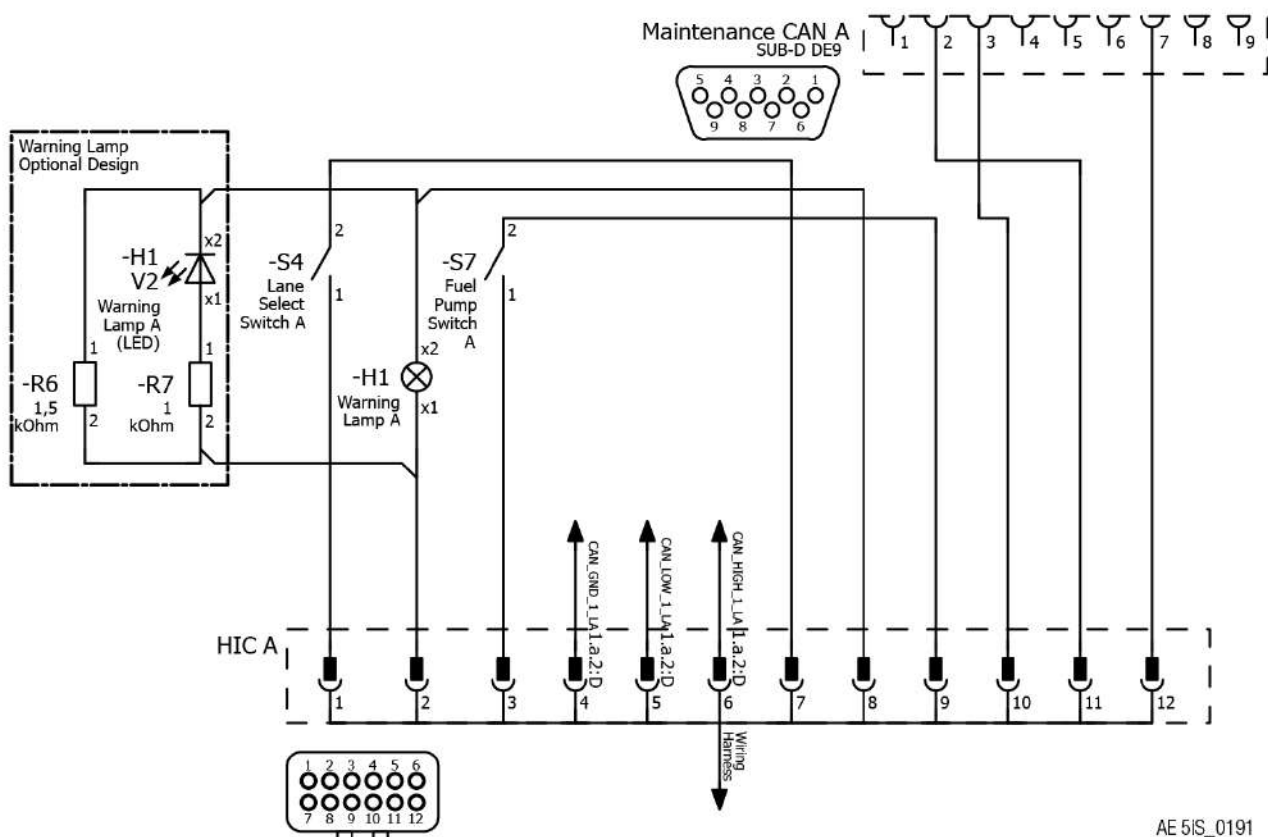

AE 5IS_0191

Figure 10.9: Harness Interface Connector A-Schematic

Part	Function
1	Harness Interface Connector A
2	Warning Lamp A (-H1)

BRP-Rotax INSTALLATION MANUAL

Part	Function
3	Warning Lamp A (LED) (-H1 V2)
4	Resistor 1.5 k Ω (-R6)
5	Resistor 1 k Ω (-R7)
6	Display CAN A
7	Maintenance CAN A

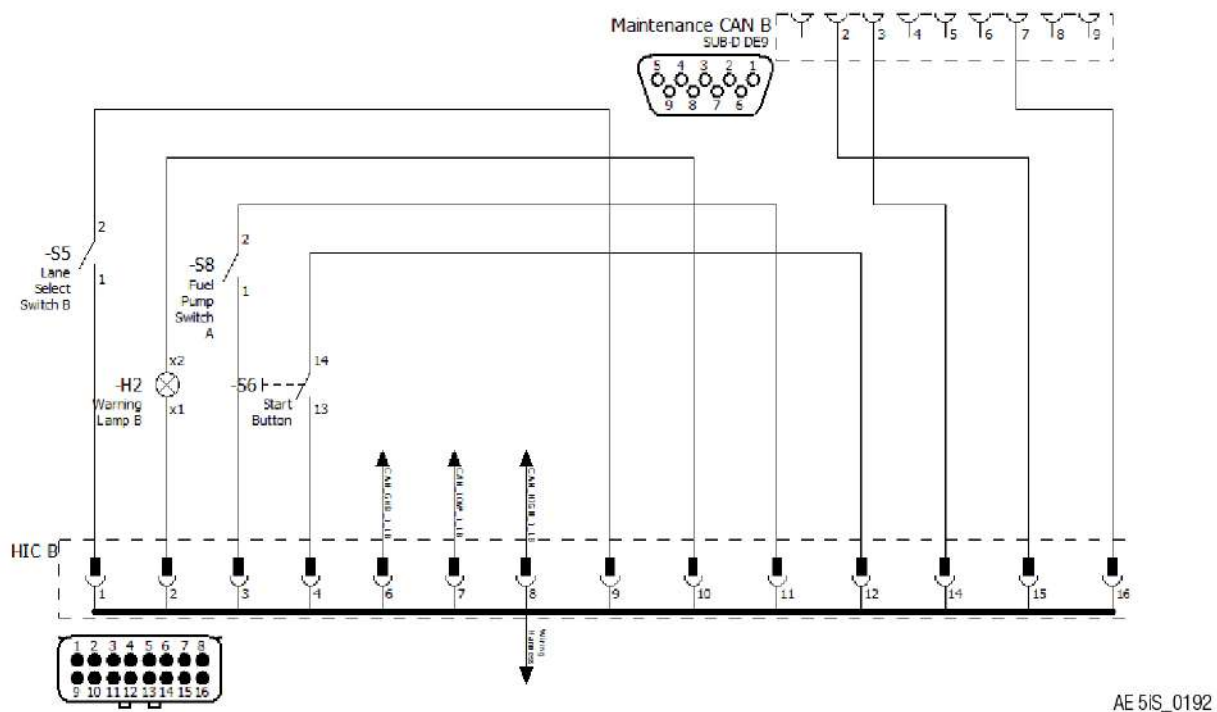

AE 5IS_0192

Figure 10.10: Harness Interface Connector B-Schematic

Part	Function
8	Harness Interface Connector B
9	Warning Lamp B (-H2)
10	Warning Lamp B (LED) (-H2 V2)
11	Resistor 1.5 k Ω (-R8)
12	Resistor 1 k Ω (-R9)
13	Display CAN B
14	Maintenance CAN B

BRP-Rotax INSTALLATION MANUAL

WARNING LAMPS

Warning Lamp A, B (-H1, -H2)

Interface Parameter	Value
Nominal voltage	12
Nominal current	max. 120 mA

Instead of common lamps also LED lamps (-H1 V2, -H2 V2) can be used. In this case a appropriate pre-resistor must be conducted serial to the LED. An additional resistor parallel to the LED prevents the ECU from detecting an open circuit at this warning lamp.

CAN INTERFACES

Display CAN

Two independent Display CAN interfaces are provided for displaying or recording engine data. When displaying engine data, it must be ensured that data of both CAN interfaces is used, providing truly redundant data indication or data indication of suitable reliability, consistent with the safety objective of the final application. The proof of consistency with the safety objective of the final application is the responsibility of the installer.

Maintenance CAN

To be able to connect the Maintenance CAN A and B with the B.U.D.S Aircraft USB-to-CAN converter the Maintenance CAN A and B should be connected with two separate Sub-D DE9 (9-pin) sockets. It is highly recommended to conduct those connectors due to the fact that the B.U.D.S. Aircraft is a central element when it comes to diagnosis and maintenance of this engine.

CAN Type	Description	HIC Pin	Sub-D DE9 Pin
Maintenance CAN A	CAN_LOW_2_A	11 (HIC A)	2
	CAN_GND_2_A	10 (HIC A)	3
	CAN_HIGH_2_A	12 (HIC A)	7
Maintenance CAN B	CAN_LOW_2_B	15 (HIC B)	2
	CAN_GND_2_B	14 (HIC B)	3
	CAN_HIGH_2_B	16 (HIC B)	7

It is recommended not to connect maintenance and diagnostic interfaces Lane A and Lane B together.

BRP-Rotax INSTALLATION MANUAL

INSTALLATION OVERVIEW – 915 I TYPE C24

915 i TYPE C 24

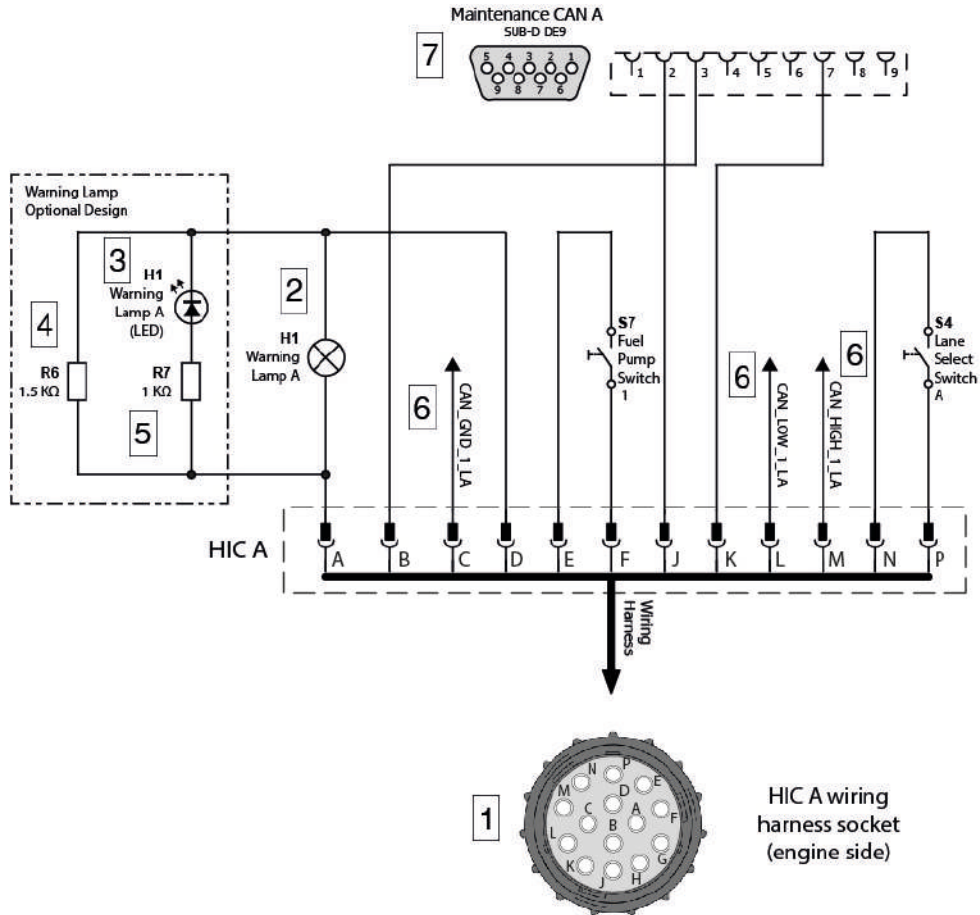
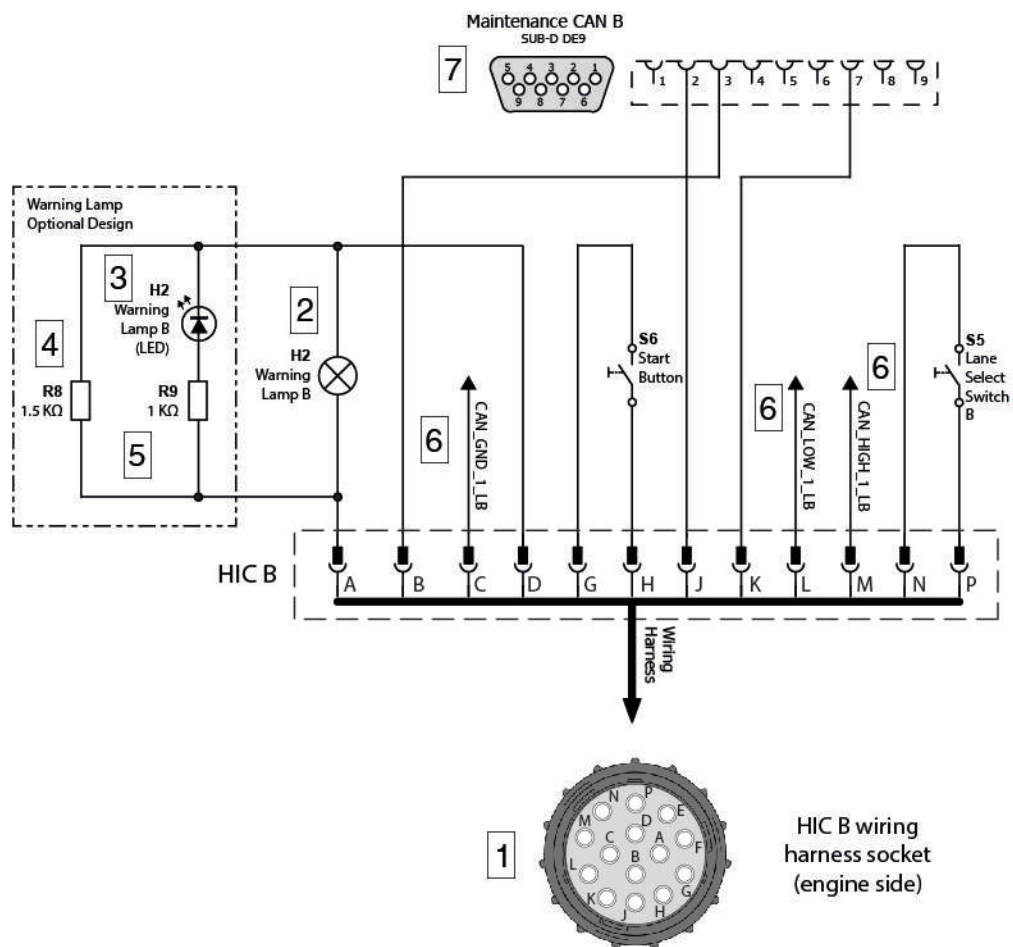

Figure 10.11: Harness Interface Connector A-Schematic

Part	Function
1	Harness Interface Connector A
2	Warning Lamp A (-H1)
3	Warning Lamp A (LED) (-H1 V2)
4	Resistor 1.5 kΩ (-R6)
5	Resistor 1 kΩ (-R7)
6	Display CAN A
7	Maintenance CAN A

BRP-Rotax INSTALLATION MANUAL



AE 5IS_0020_a

Figure 10.12: Harness Interface Connector B-Schematic

Part	Function
1	Harness Interface Connector B
2	Warning Lamp B (-H2)
3	Warning Lamp B (LED) (-H2 V2)
4	Resistor 1.5 kΩ (-R8)
5	Resistor 1 kΩ (-R9)
6	Display CAN B
7	Maintenance CAN B

BRP-Rotax INSTALLATION MANUAL

Cockpit Airframe side

Connector	PIN	Function	Type
X5	X5.1	Aircraft GND for Warning Lamps	Ground
	X5.2	Warning Lamp 14 V output EMS/Fuel pump	Signal
	X5.3	Warning Lamp Command Input (Start Power / Battery Backup)	Signal
	X5.4	Warning Lamp 28 V output Aircraft	Signal

NOTE

For improved clarity, see diagrams in Chapter 92-00-00 "Wiring diagrams".

BRP-Rotax INSTALLATION MANUAL

WARNING LAMPS – 915 I TYPE C24

Warning Lamp A,
B (-H1, -H2)

915 i TYPE C 24

Interface Parameter	Value
Nominal voltage	12 V
Nominal current	max. 120 mA

Instead of common incandescent lamps also LED lamps (-H1 V2, -H2 V2) can be used. In this case a appropriate pre-resistor must be conducted serial to the LED. An additional resistor parallel to the LED prevents the ECU from detecting an open circuit at this warning lamp.

CAN INTERFACES – 915 I TYPE C24

Display CAN

915 i TYPE C 24

Two independent Display CAN interfaces are provided for displaying or recording engine data. When displaying engine data, it must be ensured that data of both CAN interfaces is used, providing truly redundant data indication or data indication of suitable reliability, consistent with the safety objective of the final application. The proof of consistency with the safety objective of the final application is the responsibility of the installer.

Maintenance CAN

To be able to connect the Maintenance CAN A and B with the B.U.D.S Aircraft USB-to-CAN converter the Maintenance CAN A and B should be connected with two separate Sub-D DE9 (9-pin) sockets. It is highly recommended to conduct those connectors due to the fact that the B.U.D.S. Aircraft is a central element when it comes to diagnosis and maintenance of this engine.

CAN Type	Description	HIC Pin	Sub-D DE9 Pin
Maintenance CAN A	CAN_LOW_2_A	J (HIC A)	2
	CAN_GND_2_A	B (HIC A)	3
	CAN_HIGH_2_A	K (HIC A)	7
Maintenance CAN B	CAN_LOW_2_B	J (HIC B)	2
	CAN_GND_2_B	B (HIC B)	3
	CAN_HIGH_2_B	K (HIC B)	7

It is recommended not to connect maintenance and diagnostic interfaces Lane A and Lane B together.

BRP-Rotax
INSTALLATION MANUAL

INTENTIONALLY LEFT
BLANK

BRP-Rotax
INSTALLATION MANUAL

Chapter: 78-00-00
EXHAUST SYSTEM

TOPICS IN THIS CHAPTER

System description3
 System limitations3
Interface description4
 Interface overview4
 Mechanical interfaces5

BRP-Rotax
INSTALLATION MANUAL

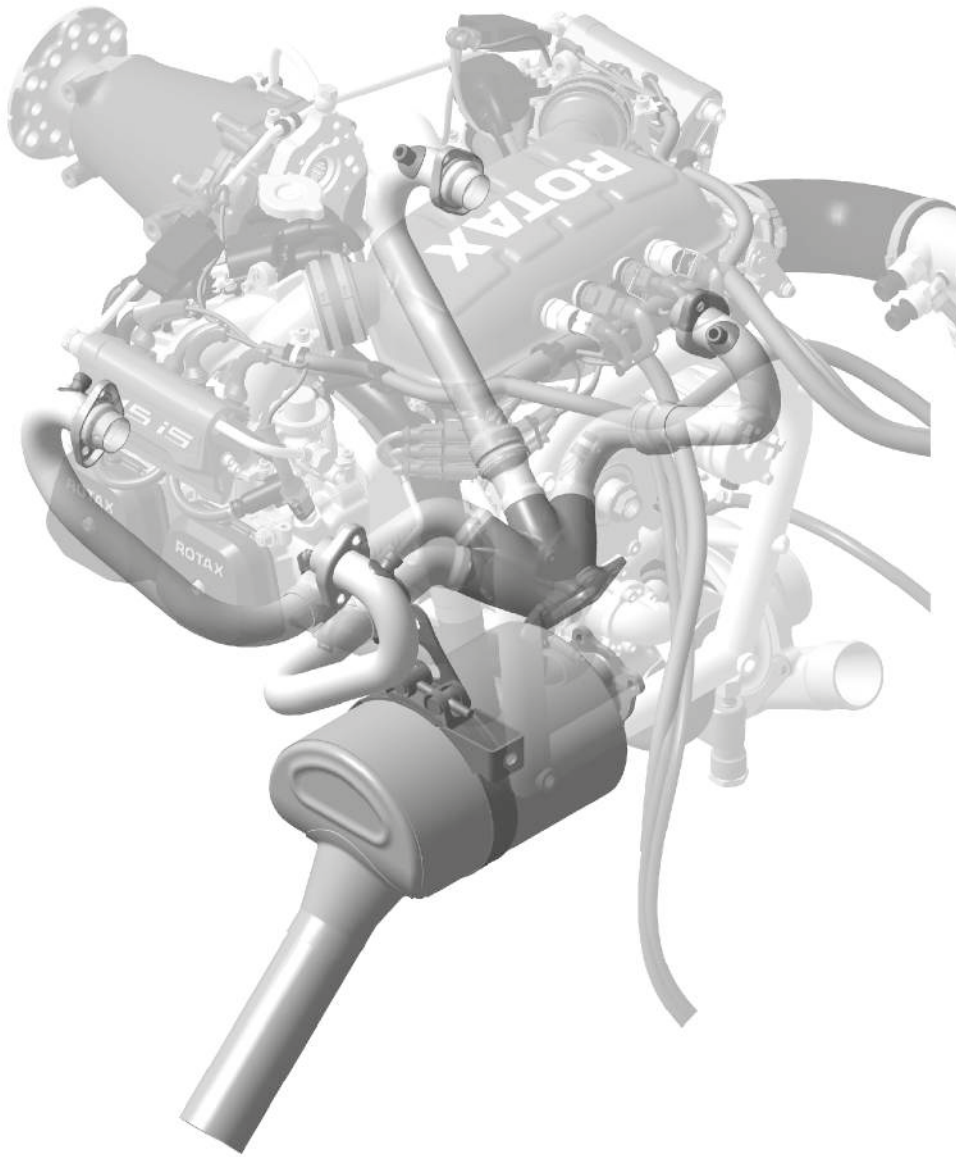

AE 5iS_0193

Figure 11.1: Exhaust system

BRP-Rotax INSTALLATION MANUAL

SYSTEM DESCRIPTION

The complete system is volume of supply and is certified together with the engine. For a detailed system description refer to latest issue of the Operators Manual (OM).

SYSTEM LIMITATIONS

Operating limits Refer to latest issue of the Operators Manual (OM).

Modifications Modifications of the system by the OEM (e.g. cut the exhaust) may be done, if following requirements are met:

- All exhaust parts added by the OEMs are decoupled (weight and vibration) from the exhaust provided
- Exhaust back pressure must not exceed following limits:

NOTE

If no modifications have been made, there is no need to check the back pressure.

System Limit	Min.	Max.
Exhaust back pressure (ambient pressure: 1000 mbar (14.50 psi))	155 mbar (2.24 psi)	180 mbar (2.61 psi)
Exhaust back pressure (ambient pressure: 900 mbar (13.05 psi))	175 mbar (2.53 psi)	205 mbar (2.97 psi)
Exhaust back pressure (ambient pressure: 800 mbar (11.60 psi))	195 mbar (2.82 psi)	230 mbar (3.33 psi)
Exhaust back pressure (ambient pressure: 700 mbar (10.15 psi))	215 mbar (3.11 psi)	255 mbar (3.69 psi)

BRP-Rotax
INSTALLATION MANUAL

INTERFACE DESCRIPTION

INTERFACE OVERVIEW

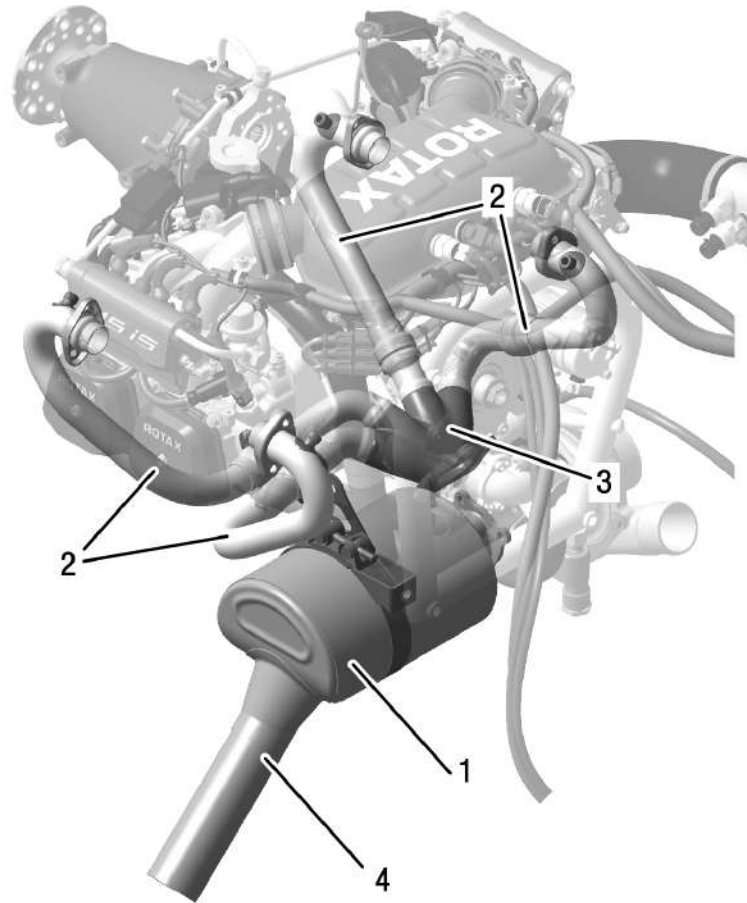

AE 515_0193a

Figure 11.2: Exhaust interfaces

- | | |
|--------------------------|-------------------|
| 1 Muffler assy. | 2 Exhaust pipe |
| 3 Exhaust manifold assy. | 4 Resonator assy. |

BRP-Rotax INSTALLATION MANUAL

MECHANICAL INTERFACES

Exhaust tail pipe

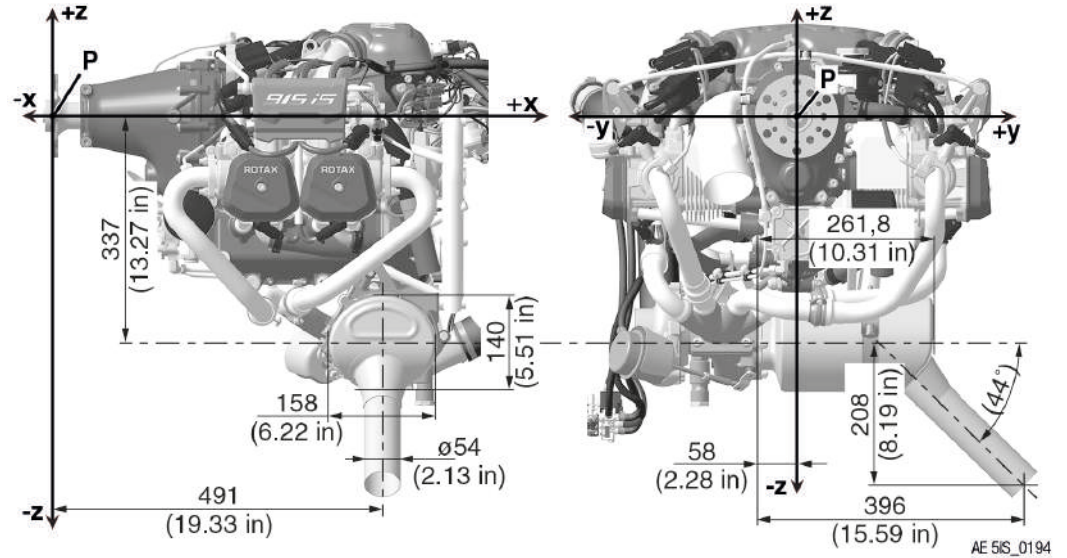

Figure 11.3: Exhaust tail pipe position

Interface Parameter	Value
Tail pipe material	1.4845 (X8CrNi25-21)

BRP-Rotax
INSTALLATION MANUAL

INTENTIONALLY LEFT
BLANK

BRP-Rotax
INSTALLATION MANUAL

Chapter: 79-00-00
LUBRICATION SYSTEM

TOPICS IN THIS CHAPTER

System description	3
System limitations	3
Crankcase pressure measurement	3
Measuring of the vacuum	5
Oil hose requirements	7
Interface description	8
Interface overview	8
Oil tank dimensions	8
Oil tank interfaces	10
Oil pump	11
Installation notes	14
Installation overview	14
Oil lines	14
Oil radiator (optional)	15
Filling and purging of the oil system	16
Validation of installation	19
Crankcase pressure measurement	19

BRP-Rotax
INSTALLATION MANUAL

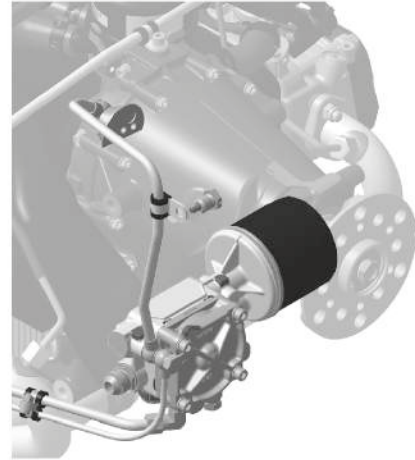
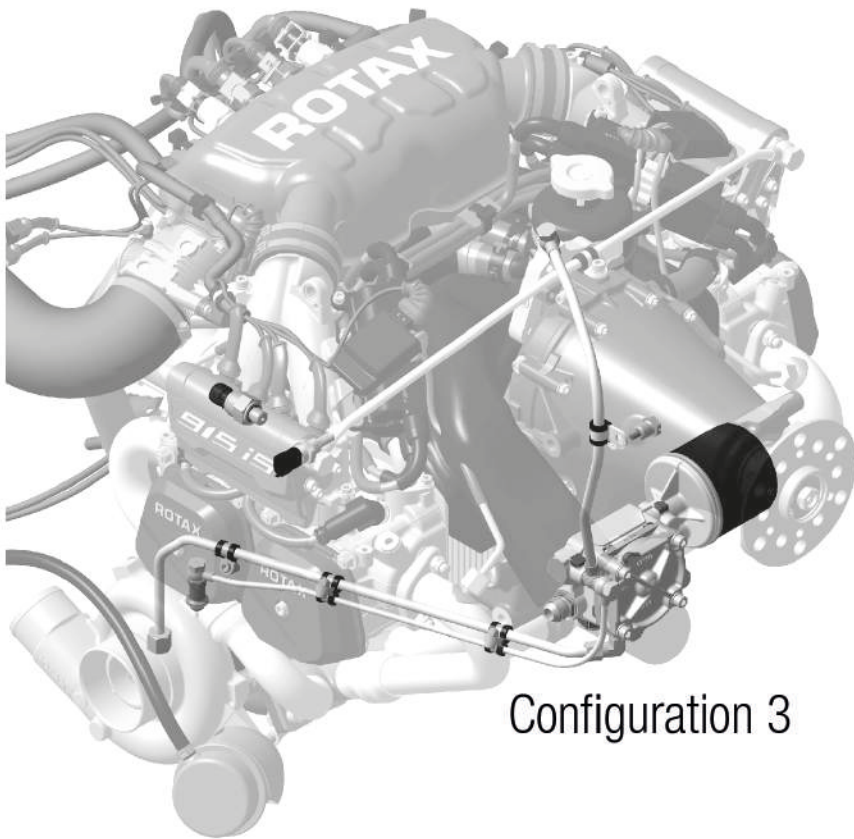

Configuration 2



AE 5iS_0195

Figure 12.1: Lubrication system, TYPICAL

BRP-Rotax INSTALLATION MANUAL

SYSTEM DESCRIPTION

For a detailed System description refer to the latest issue of the Operators Manual (OM).

SYSTEM LIMITATIONS

Operating limits Refer to latest issue of the Operators Manual (OM).

⚠ WARNING

Non-compliance can result in serious injuries or death!

The lubrication system must be designed such that the permissible operating temperatures and maximum values are not exceeded.

CRANKCASE PRESSURE MEASUREMENT

Measurement of the mean crankcase pressure at min. 50 °C (122 °F) operating temperature and full throttle, this ensures correct oil return from crankcase (blow-by gas).

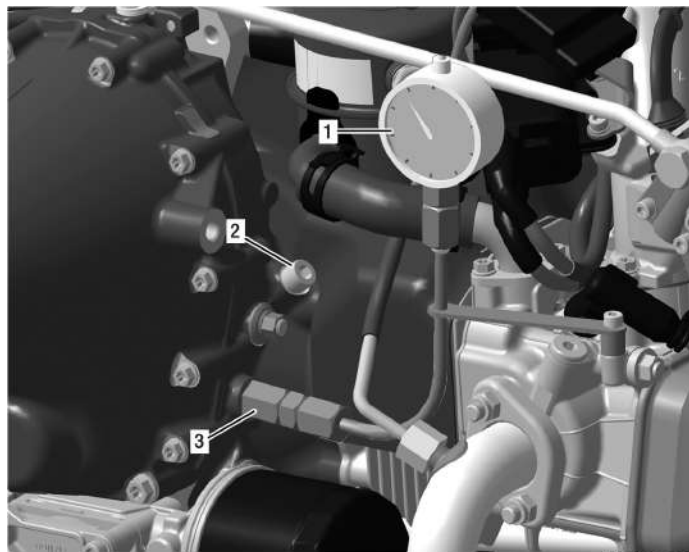

Figure 12.2: Measurement of crankcase pressure

1 Pressure indicator

2 Allen screw M8x20 (position for crankshaft locking screw)

3 Magnetic plug (position for adapter)

NOTICE

Leakage may occur!

Always use a new sealing ring with Allen screw M8 (position for crankshaft locking screw).

BRP-Rotax INSTALLATION MANUAL

NOTICE

Do not remove the magnetic plug for prolonged periods and do not use the measurement equipment during flight operations.

A pressure sensor (pressure gauge with liquid damping) can be fitted instead of the magnetic plug or the crankshaft locking screw. The magnetic plug or the crankshaft locking screw is removed and the pressure sensor is fitted.

Magnetic plug

The thread for the magnetic plug must be M12x1.5 (metric).

⚠ WARNING

Non-compliance can result in serious injuries or death!

If the readings exceed the pressure limits, then the flow resistance in the oil return line from oil sump to oil tank is too high in the current engine installation (contamination, restrictions of cross-section, etc.). This condition is unsafe and must be rectified immediately.

BRP-Rotax INSTALLATION MANUAL

MEASURING OF THE VACUUM

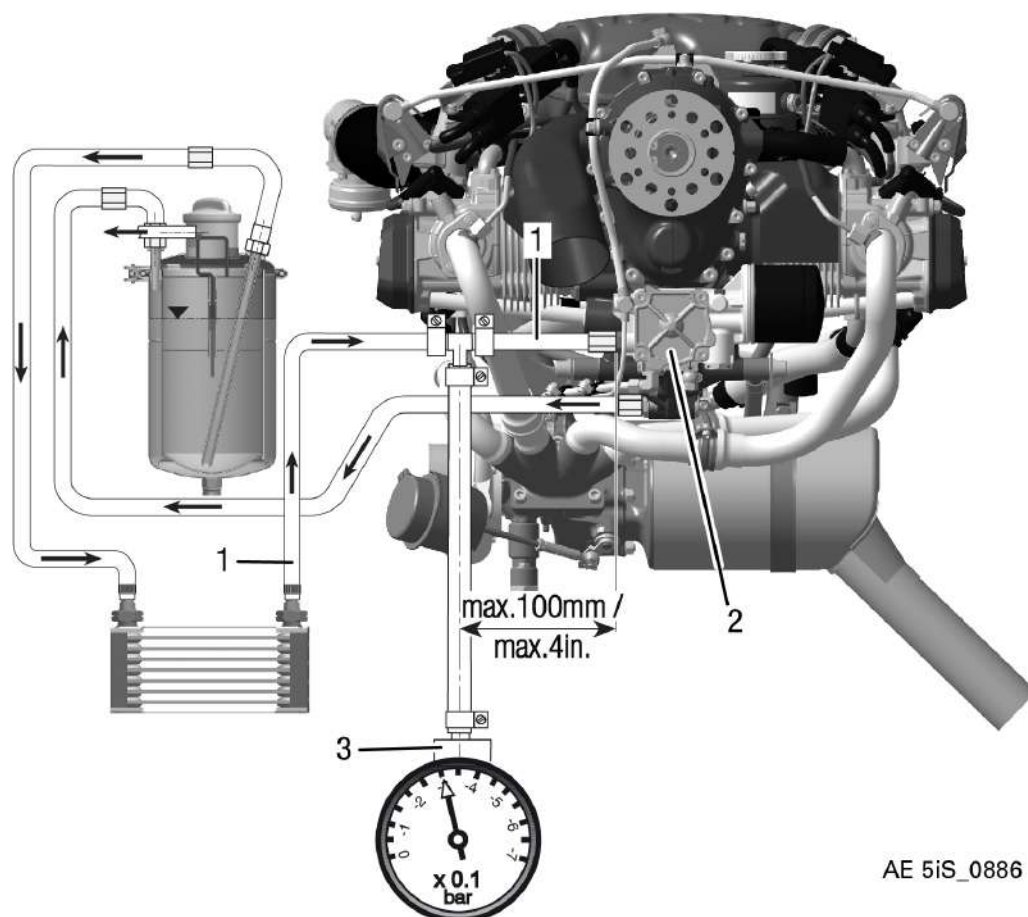

AE 5iS_0886

Figure 12.3: Measuring of the vacuum, TYPICAL

- 1 Suction oil hose
- 2 Oil pump housing
- 3 Pressure gauge with liquid damping for vacuum

Measure the vacuum in the suction oil hose- from the oil tank via the oil cooler to the engine oil pump - at a distance of max. 100 mm (4 in.) from the oil pump suction connector.

Pressure loss

Pressure loss in suction line ($p_{\text{ambient}} - p_{\text{oil pump inlet}}$) must not exceed 350 mbar (5 psi) between 70 °C – 90 °C (158 °F – 194 °F) oil temperature.

⚠ WARNING

Non-compliance can result in serious injuries or death!

The vacuum must be verified over the complete engine operation range. If the oil is cold, the flow resistance increases, which means that not enough oil will flow on the suction side.

BRP-Rotax INSTALLATION MANUAL

Oil tank installation positions

System Limit	Min.	Max.
Angular deviation	- 10°	+ 10°
Tank position in relation to engine	+40 mm (+1.57 in.)	-360 mm (-14.17 in.)

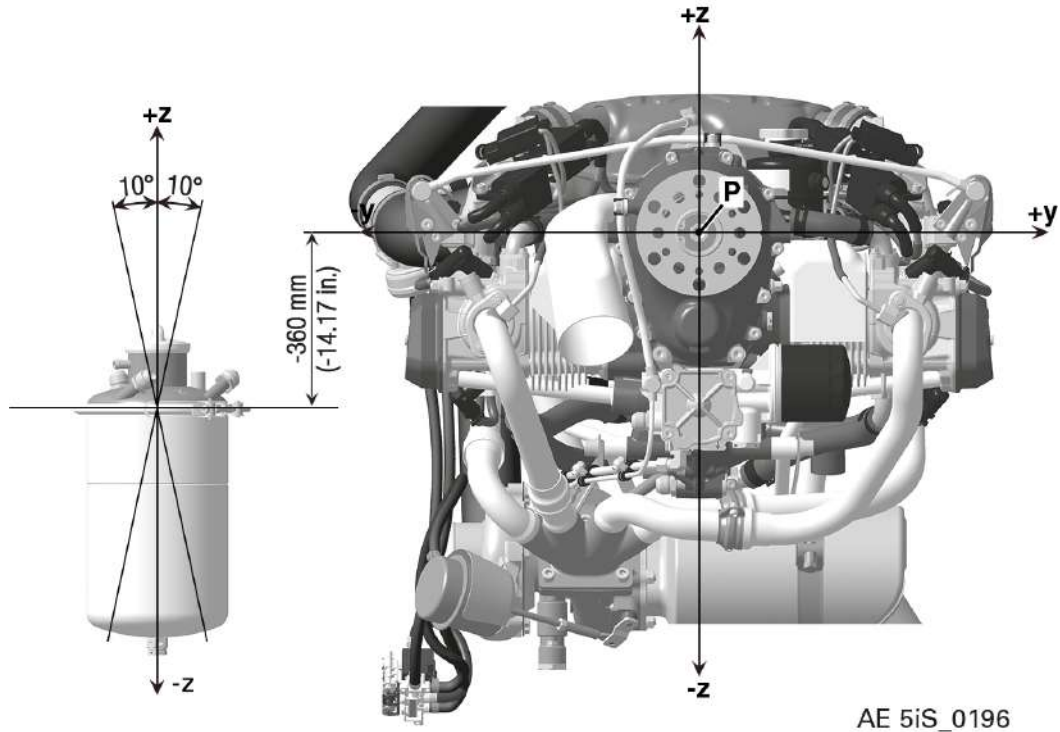

AE 5iS_0196

Figure 12.4: Oil tank installation position, TYPICAL

The oil tank must be installed on a low-vibration position and not on the engine directly. The oil tank cover and the oil drain screw must be easily accessible.

NOTE

The oil tank has to be positioned on its z-axis such that the normal oil level is always between 0 and -360 mm (-14.17 in.) on the z-axis.

BRP-Rotax INSTALLATION MANUAL

⚠ WARNING

Non-compliance can result in serious injuries or death!

At higher positioning of the oil tank, oil might leak through clearances at bearings back into crankcase. Oil tank will be empty and all oil will be in the crankcase. If fitted too low it might happen that the oil filter will be drained. In that case oil pressure will be too low for the first seconds after starting the engine.

OIL HOSE REQUIREMENTS

Main oil pump (Oil circuit, engine)

At negative pressure of -500 mbar (-7.25 psi) and a oil temperature of 150 °C (302 °F) the oil lines must not collapse.

A minimum inner diameter of at least 10 mm (0.39 in.) should be used.

NOTE

Obey the pressure requirements on interfaces as specified, see crankcase pressure and vacuum measurement.

BRP-Rotax
INSTALLATION MANUAL

INTERFACE DESCRIPTION

INTERFACE OVERVIEW

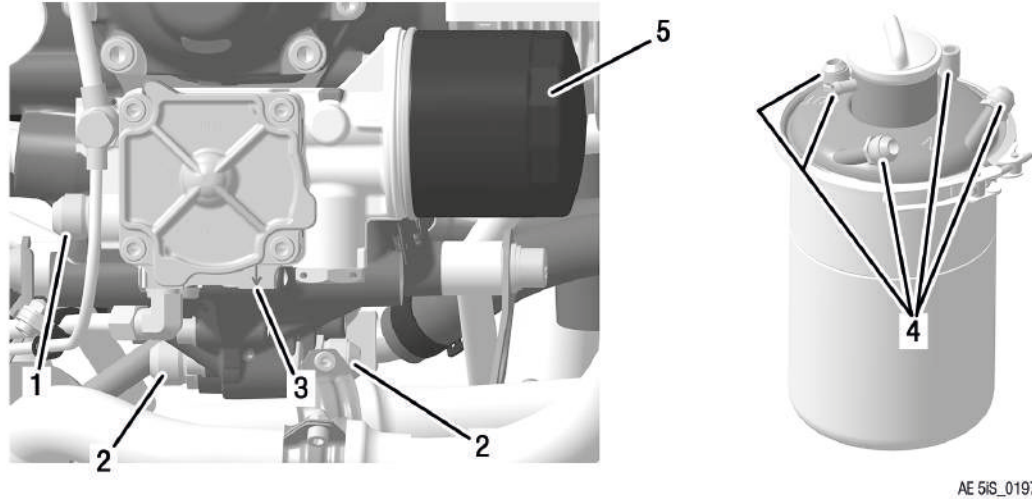

Figure 12.5: Lubrication system interfaces

- | | |
|--|--|
| 1 Oil pump inlet (hydraulic interface) | 2 Oil return outlet (hydraulic interface) |
| 3 Oil return outlet (turbocharger) (hydraulic interface) | 4 Oil tank in- and outlets (hydraulic interface) |
| 5 Oil filter (hydraulic interface) | |

OIL TANK DIMENSIONS

Oil tank The oil tank must be mounted by using appropriate clamps.

BRP-Rotax INSTALLATION MANUAL

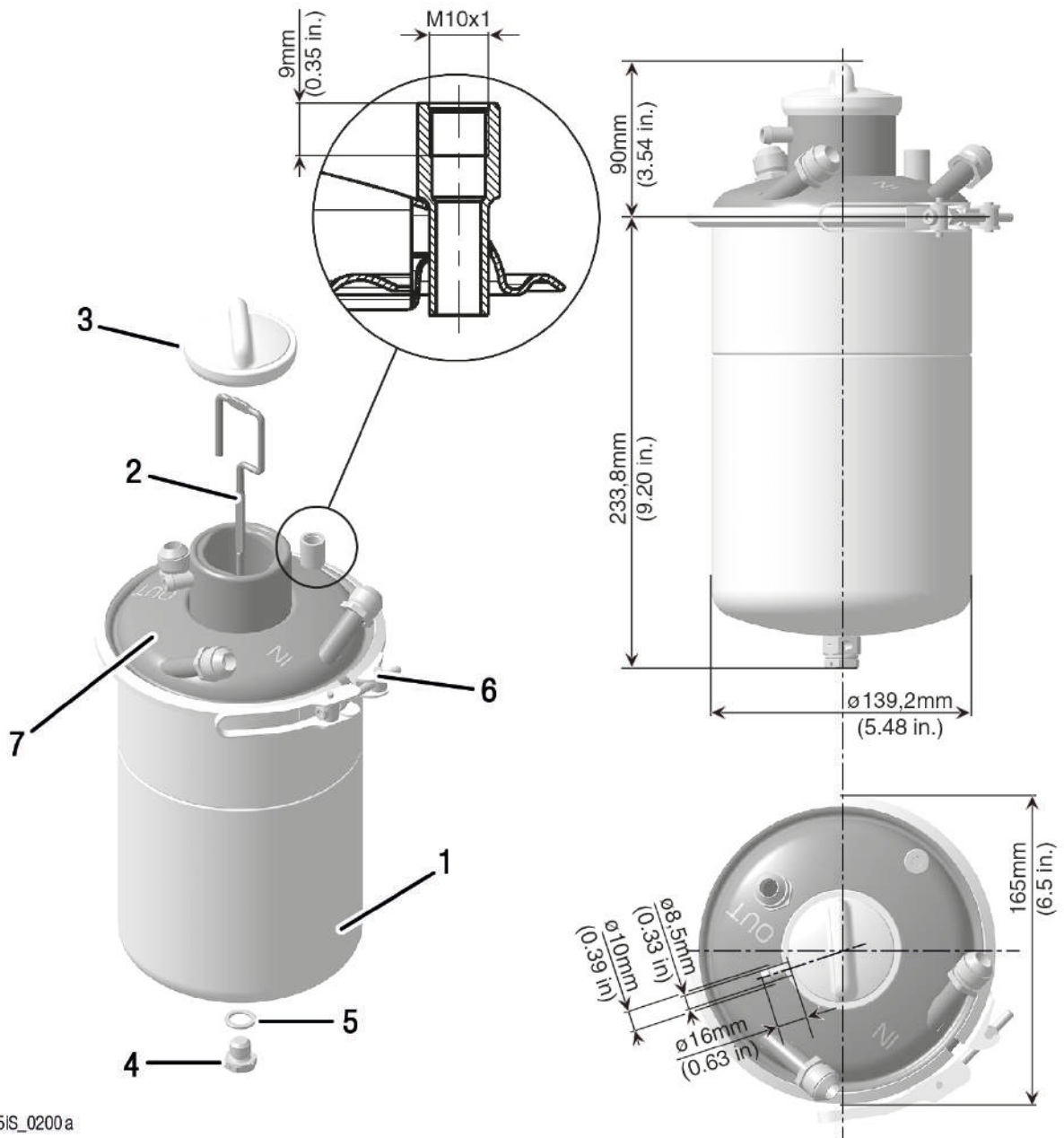

AE 5IS_0200 a

Figure 12.6: Oil tank dimensions

- | | | | | | |
|---|------------------|---|---------------------|---|-------------------|
| 1 | Oil tank | 2 | Oil dipstick | 3 | Oil bayonet cap |
| 4 | Hex. screw M12x2 | 5 | Gasket ring C 12x18 | 6 | Profile clamp 163 |
| 7 | Oil tank cover | | | | |

BRP-Rotax INSTALLATION MANUAL

OIL TANK INTERFACES

Oil tank inlet and outlet

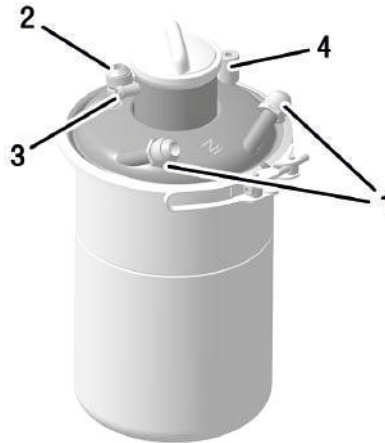

AE 5IS0199

Figure 12.7: Oil tank interfaces

- | | |
|------------------|----------------------------------|
| 1 Oil tank inlet | 2 Oil tank outlet |
| 3 Vent fitting | 4 Oil tank inlet (turbo charger) |

NOTE

The oil tank cover is also marked: *IN* — oil tank inlet, *OUT* — oil tank outlet.

NOTICE

Both oil tank inlets must be connected with the oil return outlets.

2x Oil tank inlet

Interface Parameter	Value
Screw socket	M18x1.5 or 3/4–16 UNF
Tightening torque	25 Nm (18 ft. lb)

Oil tank outlet

Interface Parameter	Value
Screw socket	M22x1.5 or 7/8–14 UNF
Tightening torque	25 Nm (18 ft. lb)

BRP-Rotax INSTALLATION MANUAL

Vent fitting

Interface Parameter	Value
Outside diameter	8 mm (0.31 in.)
Slip-on length	15 mm (0.59 in.)

⚠ WARNING

In any case the vent fitting must ensure a release of pressure from the oil tank at any time. Otherwise oil could emerge into the turbo housing which conveys through the exhaust. Formation of smoke is possible.

Oil tank inlet
(turbo charger)

Interface Parameter	Value
Screw socket	M10 x 1
Tightening torque	15 Nm (133 in. lb)

OIL PUMP

Oil pump inlet

The oil pump inlet must be connected directly with the oil tank outlet.

Interface Parameter	Value
Screw socket	M22x1.5 or 7/8–14 UNF
Tightening torque	25 Nm (18 ft. lb)

BRP-Rotax INSTALLATION MANUAL

Oil return outlet The oil return outlet must be connected directly with the oil tank inlet.

NOTICE

Both oil return outlets need to be used. Only the oil return lines on magneto side must be used. The hoses must have approx. the same length.

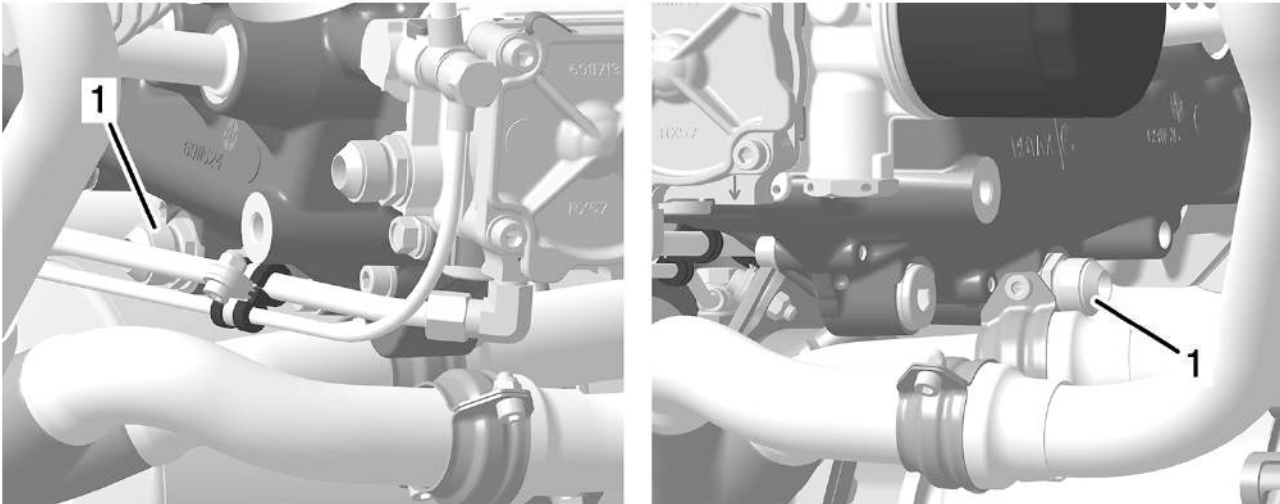

AE 5IS_0198

Figure 12.8: Oil return outlets

1 Oil return outlet

Interface Parameter	Value
Screw socket	M18x1.5 or 3/4–16 UNF
Tightening torque	25 Nm (18 ft. lb)

Oil return outlet (turbocharger) The oil return outlet (turbocharger) must be connected directly with the oil tank inlet (turbocharger).

Interface Parameter	Value
Screw socket	M10 x 1
Tightening torque	15 Nm (133 in. lb)

BRP-Rotax
INSTALLATION MANUAL

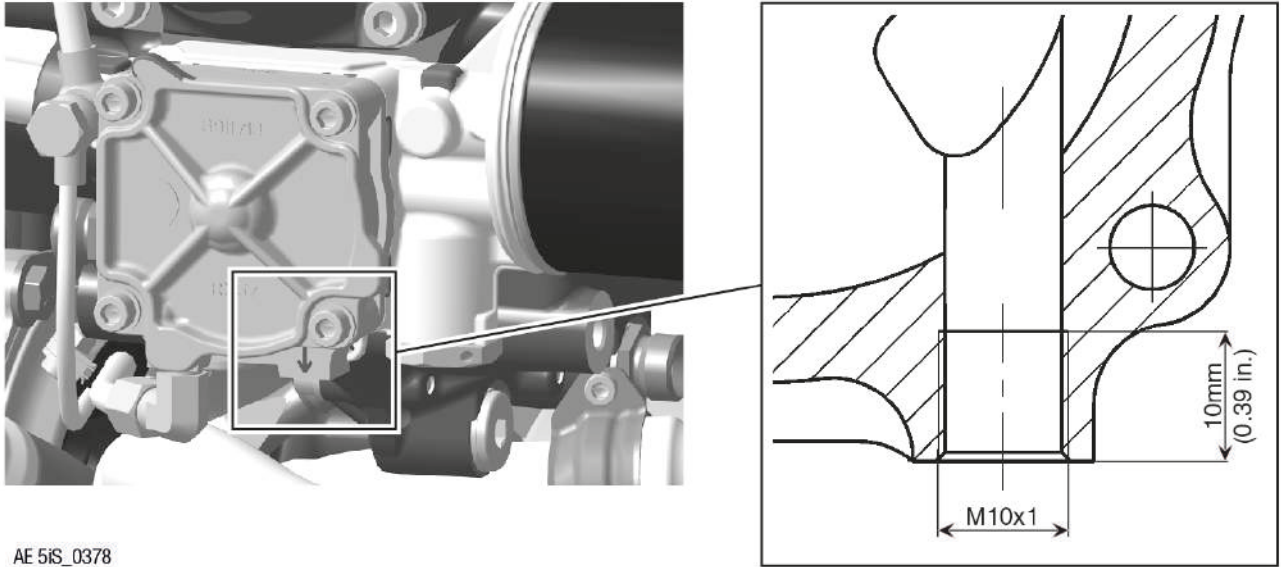

AE 5iS_0378

Figure 12.9: Oil return outlet (turbocharger)

BRP-Rotax INSTALLATION MANUAL

INSTALLATION NOTES

General

The representation of components in this chapter which are not within scope of the delivery is only symbolic. The design shown in this chapter does not represent a specified execution but should support the understanding of the system.

The final design, the selection and specification of parts according to the respective applicable regulations, the consideration of the system limitations and interface description as well as the comprehension of the operating limits in every operational state is in the responsibility of the aircraft manufacturer.

The aircraft manufacturer has to make sure that the operating limits given in the Operators Manual (OM) can be supervised by the pilot. The execution of the installation must allow the operation of the engine according to the Operators Manual (OM).

INSTALLATION OVERVIEW

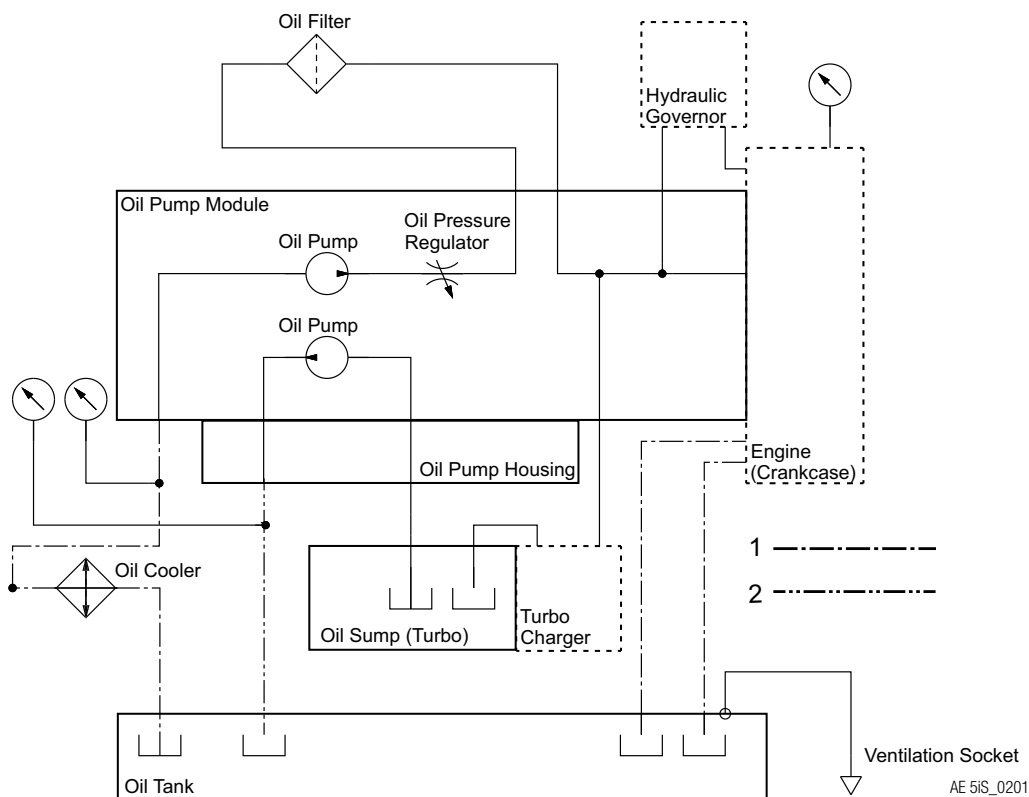

Figure 12.10: Lubrication system overview

1 Engine circuit

2 Turbocharger return line

OIL LINES

At negative pressure of -500 mbar (-7.25 psi) and a oil temperature of 140 °C (284 °F) the oil lines must not collapse.

A minimum inner diameter of at least 10 mm (0.39 in.) should be used.

BRP-Rotax INSTALLATION MANUAL

Oil tank venting line

Following points should be considered when installing the oil tank venting line:

- Route the line without kinks and avoid sharp bends
- Route the venting line in a continuous decline. Otherwise a drain bore at the lowest point should be foreseen to drain any condensate.

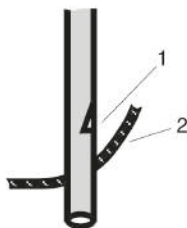

Figure 12.11: Bypass opening

1 Bypass opening

2 Cowling

NOTE

Water is a by-product of the combustion of fuel. Most of this water will dissipate from the combustion chamber with the exhaust gases. A small amount will reach the crankcase and must be disposed of through a venting line.

The venting line must be protected from any kind of ice formation for condensation by using e.g. isolation protection or a routing in a hose with hot air flow. Additionally a bypass opening should be foreseen before the cowling outlet.

OIL RADIATOR (OPTIONAL)

Essential parts of the cooling system, such as radiator, etc., are available for this engine from BRP-Rotax. See also SI-PAC-014.Oil radiator /-sets.

⚠ WARNING

Non-compliance can result in serious injuries or death!

The furnishing of proof in accordance to the latest FAR and EASA, has to be conducted by the aircraft manufacturer.

Specifications of the oil radiator

The radiator must be designed to dissipate approx. 30 kW (28.43 BTU/s) of thermal energy at take-off performance.

Weight: max. 0.82 kg (1.8 lb) for oil radiator "extra large".

NOTICE

The oil radiator must not restrict oil flow. Test system as per section "Checking the oil circuit".

BRP-Rotax

INSTALLATION MANUAL

FILLING AND PURGING OF THE OIL SYSTEM

Introduction

Ensure that oil lines are connected correctly and secured. Also ensure that the oil cooler (if fitted) is in the suction line between the oil tank and the oil pump, see following figure. Verify that the oil tank is filled up to the maximum level (to the top of the flat portion of the dipstick). The capacity of the oil system without oil cooler and connection lines is approx. 3l (0.66 gal.). Additional oil (up to 0.5 litres (0.13 gal)) may be added to the tank for the purpose of this procedure.

Instruction

The following work procedures must be carried out for purging the oil system:

1. Disconnect oil return lines (2) from the oil tank.
2. Place the free end of the return lines into a suitable container (4) below the engine.
3. Plug open connections on oil tank with suitable air tight cap.
4. Remove the spark plug connections.
5. For easier rotation of engine remove one spark plug from each cylinder.

NOTE

Prevent any foreign objects entering the spark plug hole.

6. Using a compressed air line, pressurize the oil tank through its vent fitting (6) (on the neck of the tank). Adjust the compressor outlet regulator so that the air line pressure is between 0.4 bar (5.8 psi) and 1 bar (14.5 psi). Do not exceed 1 bar (14.5 psi).

NOTE

The oil tank bayonet cap is not pressure-tight, some air can escape.

7. Turn the engine by hand in direction of normal rotation until the first pressure indication appears on the oil pressure gauge. Normally this will take approx. 20 turns. Depending on installation it may take up to 60 turns.

NOTE

Do not use the starter for this purpose. Fit propeller and use it to turn the engine by hand.

NOTE

The oil tank may empty and as a result introduce air into the oil system. Pay attention to the oil level and fill tank as required.

8. Stop the pressurization.
9. Open the cap for the oil return lines on the oil tank and reconnect the engine oil return lines to the tank. Ensure that the suction oil line and oil return line are connected to proper fittings on the oil tank. Note: If the oil lines from engine to oil tank are incorrectly connected, severe engine damage may result.
10. Re-fit the spark plugs. Restore aircraft to original operating condition.
11. Residual oil may have accumulated in the crankcase. Return it to the oil tank by following the oil level check procedure in the relevant Operators Manual (OM).

BRP-Rotax INSTALLATION MANUAL

12. Fill the oil in the tank up to the full mark on the dipstick.
13. Carefully check all lubrication system connections, lines and clamps for leaks and tightness.

ENVIRONMENTAL NOTE

Protect the environment! Do not spill oil and pay attention for adequate disposal.

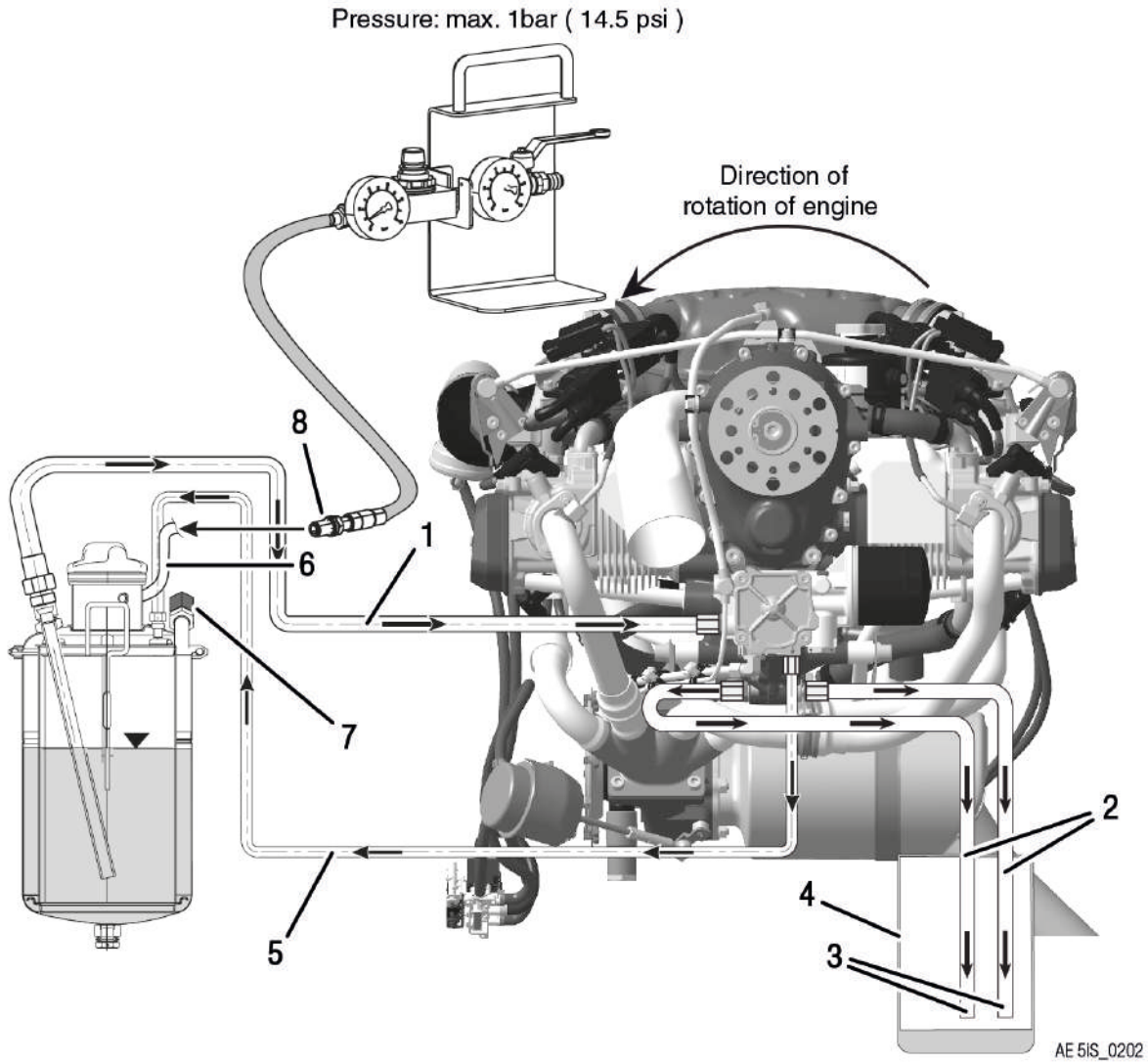

Figure 12.12: Setup for purging the oil system

- | | |
|----------------|---------------------------------|
| 1 Suction line | 2 Oil return line |
| 3 Free end | 4 Temporary oil collection tank |

BRP-Rotax
INSTALLATION MANUAL

5 *Oil return line*

6 *Vent fitting*

7 *Plug (2x)*

8 *Temporary connection for purging*

BRP-Rotax INSTALLATION MANUAL

VALIDATION OF INSTALLATION

General

The validation procedures described in this chapter do not claim to be complete. The correct execution and compliance with all given system limitations and interface descriptions as well as with standards and norms given by authorities must be proven by the aircraft manufacturer.

CRANKCASE PRESSURE MEASUREMENT

1. Remove magnetic plug or crankshaft locking screw.
2. Attach pressure sensor (pressure gauge with liquid damping). The thread for the magnetic plug must be M12x1,5 (metric). The thread for the crankshaft lock pin hole must be M8.
3. Start the engine according the Operators Manual (OM) and read the crankcase pressure value at full throttle.
4. Compare the read out value with the limitations for the crankcase pressure specified in the section "System Limitations" of this chapter.
If the readings exceed the pressure limits, then the flow resistance in the oil return line from oil sump to oil line is too high in the current engine installation (contamination, restrictions of cross-section etc.) This condition is unsafe and must be rectified immediately.
5. Re-install magnetic plug or screw into crankshaft locking pin hole. When reinstalling the screw always use a new gasket.

BRP-Rotax
INSTALLATION MANUAL

INTENTIONALLY LEFT
BLANK

BRP-Rotax
INSTALLATION MANUAL

Chapter: 80-00-00
STARTING

TOPICS IN THIS CHAPTER

System description **3**
 System limitations 3

Interface description **4**
 Interface overview 4
 Electrical interfaces 4

Installation notes **6**
 Installation overview 6
 Wiring 7

Starter relay assy. technical data **9**

Validation of installation **11**

BRP-Rotax
INSTALLATION MANUAL

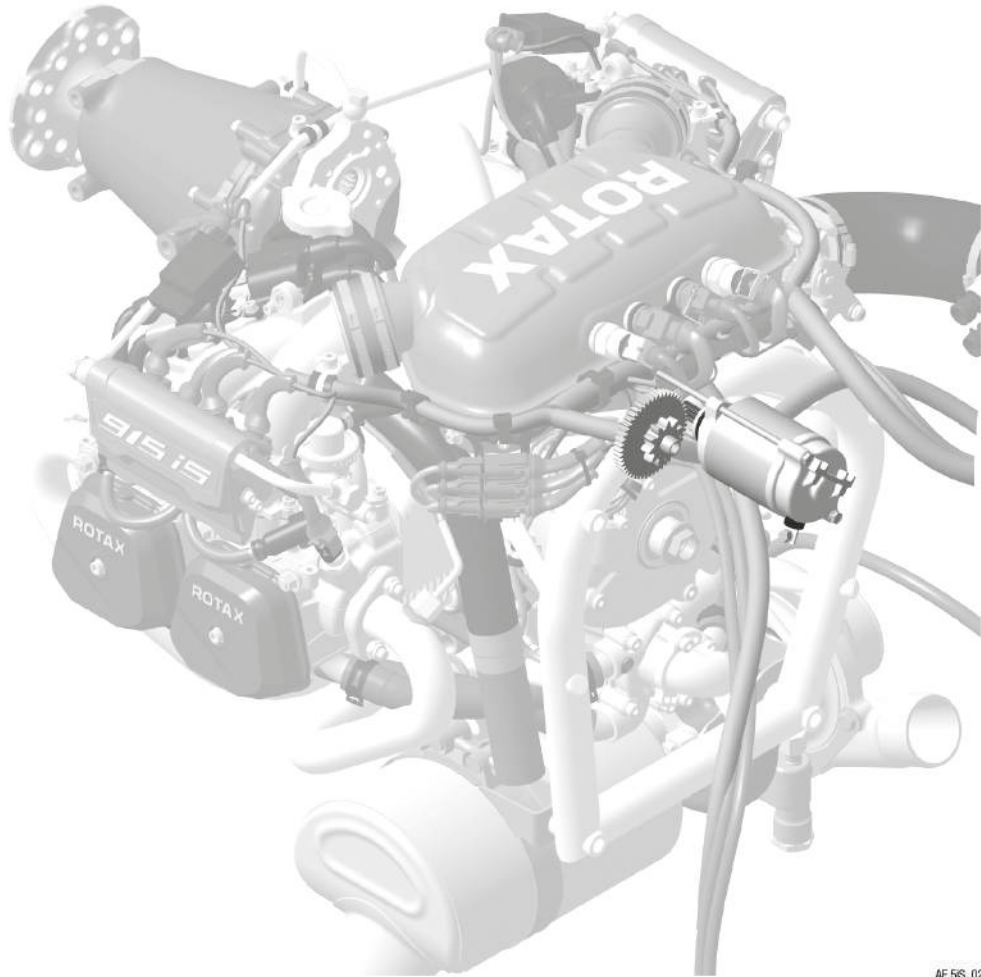

AE 516_0203

Figure 13.1: Starting, TYPICAL

BRP-Rotax
INSTALLATION MANUAL

SYSTEM DESCRIPTION

For a detailed System description refer to the latest issue of the Operators Manual (OM).

SYSTEM LIMITATIONS

Operating limits Refer to latest issue of the Operators Manual (OM).

Ambient temperatures

System Limit	Min.	Max.
Electric Starter	- 40 °C (- 40 °F)	80 °C (176 °F)

Thermal durability Suitable for short starting periods only. Activate starter for max. 10 seconds (without interruption), followed by a cooling period of 2 minutes.

Aircraft ground The engine block must be connected to the aircraft using a properly sized ground strap (minimum the same cable cross section as starter supply), to provide the required starter current and to avoid static electricity between the engine and the aircraft.

BRP-Rotax
INSTALLATION MANUAL

INTERFACE DESCRIPTION

INTERFACE OVERVIEW

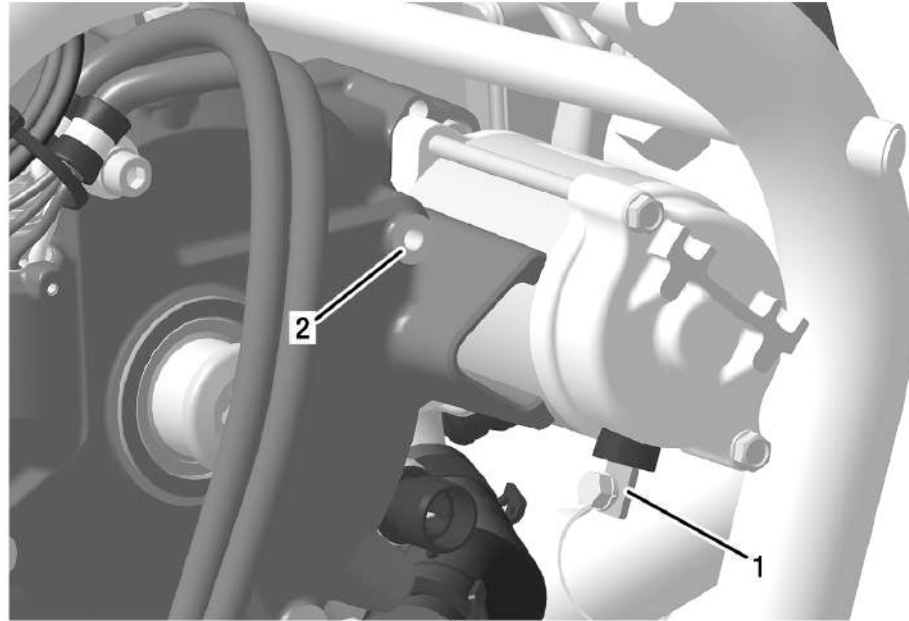

AE 5iS_0036

Figure 13.2: Starter interfaces

1 Positive terminal

2 Negative terminal

ELECTRICAL INTERFACES

Positive terminal **915 i TYPE A**

Interface Parameter	Min.	Max.	Nominal
Input voltage:			12 V
Input load:* * for resistance of starter circuit R _{smax} = <20 mOhm	20 A	350 A ⁵	

The terminal must be conducted as M5 screw connection suitable for cable lug according to DIN 46225.

Tightening torque: Min. 3 Nm (27 in.lb) Max. 5 Nm (44 in.lb).

5. When electric starter is activated

BRP-Rotax INSTALLATION MANUAL

Positive terminal

915 i TYPE C24

Interface Parameter	Min.	Max.	Nominal
Input voltage:			24 V
Input load:* * for resistance of starter circuit R _{smax} = <20 mOhm	20 A	350 A ⁶	

The terminal must be conducted as M5 screw connection suitable for cable lug according to DIN 46225.

Tightening torque: Min. 3 Nm (27 in.lb) Max. 5 Nm (44 in.lb).

Negative terminal

The engine block must be connected to the airframe using a properly sized ground strap (minimum the same cable cross section as the starter supply), for carrying the starter current and to avoid static electricity between the engine and the airframe.

6. When electric starter is activated

BRP-Rotax INSTALLATION MANUAL

INSTALLATION NOTES

General

The representation of components in this chapter which are not within scope of the delivery is only symbolic. The design shown in this chapter does not represent a specified execution but should support the understanding of the system.

The final design, the selection and specification of parts according to the respective applicable regulations, the consideration of the system limitations and interface description as well as the comprehension of the operating limits in every operational state is in the responsibility of the aircraft manufacturer.

The aircraft manufacturer has to make sure that the operating limits given in the Operators Manual (OM) can be supervised by the pilot. The execution of the installation must allow the operation of the engine according to the Operators Manual (OM).

INSTALLATION OVERVIEW

915 i TYPE A

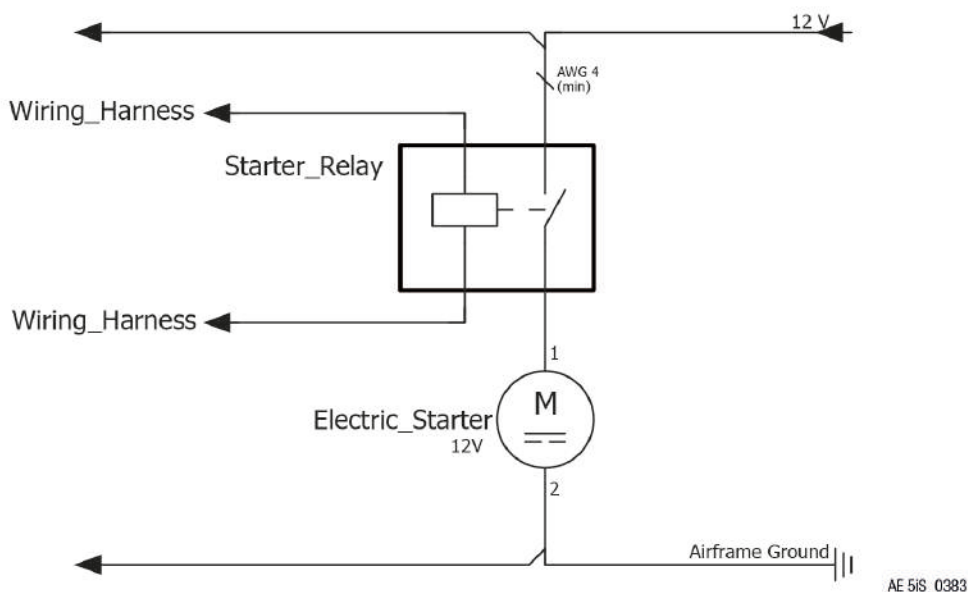

Figure 13.3: Engine starting circuit

BRP-Rotax INSTALLATION MANUAL

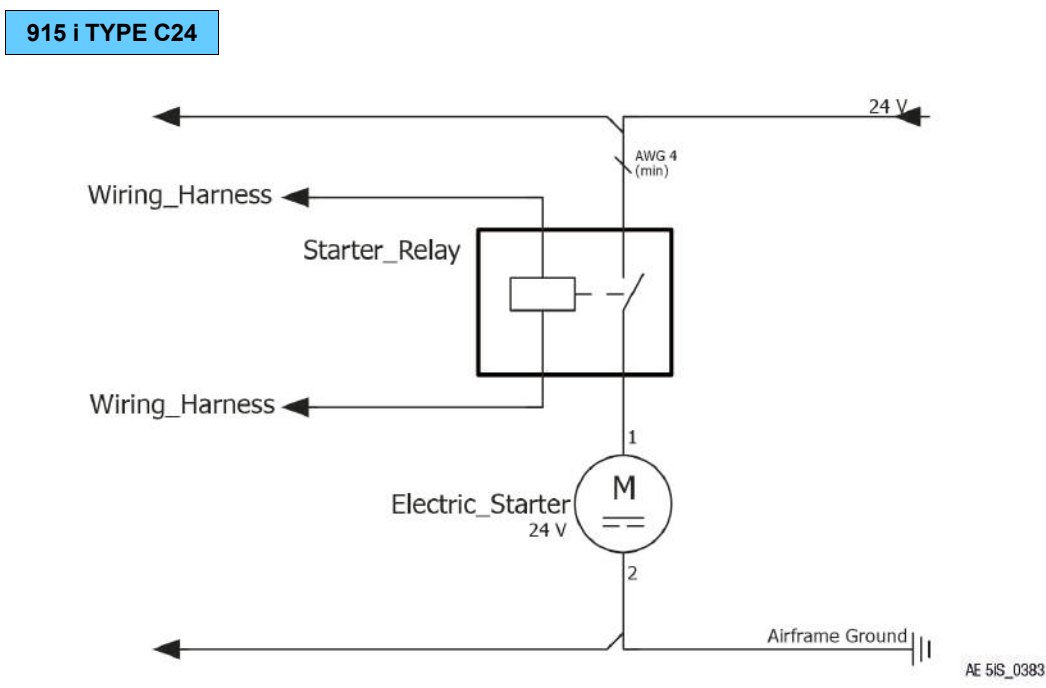

Figure 13.4: Engine starting circuit

WIRING

The minimum cable cross-section for the line from the battery to the starter relay and from there to the electric starter and for the ground line (start system) depends on the cable length "l" (= Sum of the supply line and ground line of the electric starter) and has to be calculated according to the following table.

l [m]	l [ft]	A _{min.} [mm ²]	A _{min.} [in ²]	A _{max.} [mm ²]	A _{max.} [in ²]	AWG _{min.}
<4	<13	20.408	0.031	25	0.039	4
4<l<4.5	13<l<14.8	22.959	0.036	35	0.054	3
4.5<l<5	14.8<l<16.4	25.51	0.04	35	0.054	3
5<l<5.5	16.4<l<18	28.061	0.043	35	0.054	2
5.5<l<6	18<l<19.7	30.612	0.047	35	0.054	2
6<l<6.5	19.7<l<21.3	33.163	0.051	35	0.054	2
6.5<l<7	21.3<l<23	35.714	0.055	50	0.078	1
7<l<7.5	23<l<24.6	38.265	0.059	50	0.078	1
7.5<l<8	24.6<l<26.2	40.816	0.063	50	0.078	1
8<l<8.5	26.2<l<27.9	43.367	0.067	70	0.109	0
8.5<l<9	27.9<l<29.5	45.918	0.071	70	0.109	0

BRP-Rotax INSTALLATION MANUAL

I [m]	I [ft]	A _{min.} [mm ²]	A _{min.} [in ²]	A _{max.} [mm ²]	A _{max.} [in ²]	AWG _{min.}
9<I<9.5	29.5<I<31.2	48.469	0.075	70	0.109	0
9.5<I<10	31.2<I<32.8	51.02	0.079	70	0.109	0

The internal resistance of the battery and the resistance of the electrical system (wires, contact points, relay contacts) largely determine the performance of the starting system. Therefore, the total loop resistance (R_{Smax}) may not exceed 0.015 Ω .

$$R_{Smax} = \sum R = R_{iBatt} + R_{C \text{ Starter relay}} + R_L + R_{Other}$$

Symbol	Description
R_{iBatt}	Inner resistance of battery
$R_{C \text{ Starter Relay}}$	Contact resistance starter relay
R_L	Line resistance
R_{Other}	Any other resistor (e.g. Master relay, contact resistance...)

BRP-Rotax
INSTALLATION MANUAL

STARTER RELAY ASSY. TECHNICAL DATA

NOTICE

Activation of starter relay limited to short duration. The duty cycle over an interval of 4 minutes is 25%.

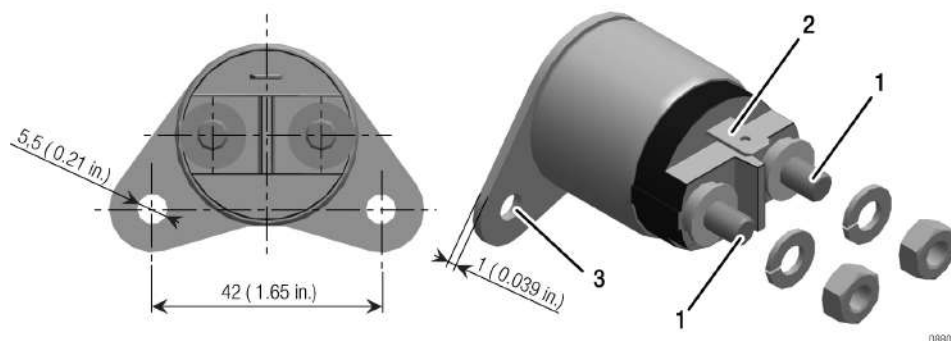

Figure 13.5: Starter relay

- 1 Main current connections
- 2 Control wiring
- 3 Mounting point

Nominal voltage	12 V/DC
Control voltage	min. 6 V / max. 18 V
Switching current	max. 75 A (permanent) max. 300 A/1 s (short duration)
Permissible ambient temperature	min. -40 °C (-40 °F) / max. +100 °C (212 °F)
Weight	See Chapter 72-00-00 section Weight.
Main current connections	M6 screw connection (tightening torque 4 Nm (36 in.lb.)) suitable for cable terminals according to DIN 46225 (MIL-T-7928; PIDG or equivalent).
Control wiring	6.3x0.8 plug connector suitable for Faston connector (female) according to DIN 46247 (MIL-T-7928; (PIDG) or equivalent).

BRP-Rotax
INSTALLATION MANUAL

Grounding

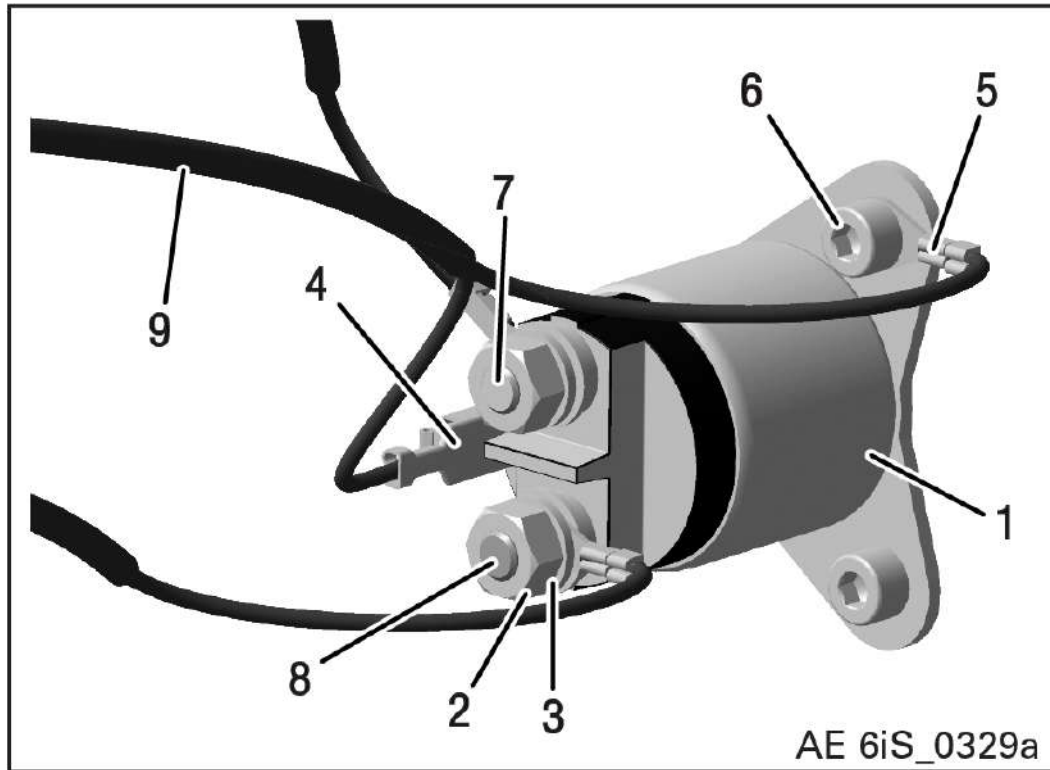

Figure 13.6: Starter relay

- | | |
|---------------------------|---------------|
| 1 Starter relay | 2 Hex. nut M6 |
| 3 Washer 6.4 | 4 Terminal S |
| 5 Ground | 6 Bolt/screw |
| 7 Terminal B | 8 Terminal M |
| 9 Wiring harness (Engine) | |

BRP-Rotax
INSTALLATION MANUAL

VALIDATION OF INSTALLATION

General

The validation procedures described in this chapter do not claim to be complete. The correct execution and compliance with all given system limitations and interface descriptions as well as with standards and norms given by authorities must be proven by the aircraft manufacturer.

BRP-Rotax
INSTALLATION MANUAL

INTENTIONALLY LEFT
BLANK

BRP-Rotax
INSTALLATION MANUAL

Chapter: 92-00-00
WIRING DIAGRAMS

TOPICS IN THIS CHAPTER

General

This Chapter contains the wiring diagrams for each relevant engine system installation.

The wiring diagrams have the same numbering system and abbreviations as used in this Manual

Title	Drawing Number	Rev. Number	Number of Sheets
Wiring diagram ROTAX® 915 I Type A	AE_5iS_0160	0	1
Wiring diagram ROTAX® 915 I Type C24	AE_5iS_0830	0	1

BRP-Rotax
INSTALLATION MANUAL

INTENTIONALLY LEFT
BLANK

BRP-Rotax
INSTALLATION MANUAL

Chapter: APPENDIX
OPERATIONAL AND INSTALLATION CONSIDERATIONS

TOPICS IN THIS CHAPTER

Scope	2
Fuel pumps and power supplies	3
Engine starting, Start power switching system and Starting system	4
Lane select switching system – Ignition switching	5
Failure behavior and Warning annunciation to the pilot	6
Simplified EMS Matrix 915 i A Series	7
Hypothesis on warning lamp execution in the aircraft	15
System availability and reliability	16
Electrical bonding	17

BRP-Rotax INSTALLATION MANUAL

SCOPE

The current version of the Operators Manual provides information on pilot action in the case of abnormal engine operation (see Chapter 4, section 4.1: Engine failures in flight). The current information (table) provides a very conservative position which might not allow to tap the full potential of the engine's operational ability if referring to this table only. For this reason, an additional section in written form is provided in the Installation Manual, explaining engine behavior in very simple form, with the intention to allow the installer tailoring evaluation of system behavior and failure severity classification and thus pilot action for a specific aircraft installation.

Prediction of pilot action is not possible to the engine system designer entirely, since this may vary with actual conditions arising from installation in a specific aircraft (SEP, MEP, Aircraft Type, Operational Conditions, etc.). It therefore might seem appropriate to provide a more detailed description of the engine system behavior in the case of failures, rather than providing a given pilot reaction, not knowing about the aircraft installation in every detail.

With upcoming installation projects based on different aircraft certification specifications it is now found that the current documentation should be refined and or changed to better meet the demands of installers.

This written document should furthermore provide a better understanding for interpretation and implementation of the following topics:

- Fuel pumps and power supplies
- Engine starting, start power switching system and Starting system
- Lane select switching system – Ignition switching
- Failure behavior and warning annunciation to the pilot
- Failure consideration beyond Installation Interfaces
- Hypothesis on warning lamp execution in the aircraft
- System availability and reliability
- Electrical bonding

BRP-Rotax INSTALLATION MANUAL

FUEL PUMPS AND POWER SUPPLIES

The 915 i A Series provides the possibility to supply fuel pumps from the engine electric supply system. It provides a connector for connection of two electric fuel pumps (not engine type design) and furthermore the possibility to actuate these fuel pumps via the HIC (Harness Interface connector). At the HIC position two fuel pump switching systems (not engine type design) are required to provide the fuel pump ON/OFF function. From engine system perspective these fuel pump switching systems are required to allow a real check of the functional performance of each pump, meaning completely switching off the opposite fuel pump, while the current engaged fuel pump must supply the engine stand alone.

The 915 i A Series power supply system comprises two separate permanent magnet alternators (engine internal, on a single stator but completely physically separated), two independent Voltage regulators, including voltage smoothing capacitors, etc. This forms two **independent power supply** sources which are each able to power the Engine Management System (EMS) entirely. These power supply systems produce power once the engine is turning, each completely independent and completely galvanic separated from the aircraft power supply (when Start power OFF and backup battery OFF). For this reason, there is no dependence and interaction between engine power supply and aircraft power supply at all. The two power supply systems are not specifically dedicated to the two fuel pumps. They are rather dedicated to the entire EMS, meaning power supply system Generator A is supplying the entire EMS including both fuel pumps in common operation mode. In the case of a faulty power supply system Generator A the power supply system Generator B is automatically engaged and supplying the EMS including both fuel pumps. This means not only a backup pump receives an independent power supply but rather each control system including each fuel pump has a redundant independent power supply.

Engagement of the backup power supply system Generator B is done by the Engine Control Unit (ECU) in the case of over voltage and under voltage. If the voltage of power supply system Generator A decreases significantly or at all, the control transition of the power supplies is additionally done per mechanical means (relays drop out). These mechanism allow engagement of backup power supply under every probable circumstance.

If power supply system Generator B is used to supply the aircraft electrical system (possible in common operation mode) it must be noted that in case of failure this power supply system B is disconnected from the aircraft to serve as the backup to the EMS.

The ECU does not control and monitor the fuel pumps. The EMS provides the possibility to supply and control the fuel pumps.

The aspect "**directly driven fuel pump**" as required in various aircraft certification specifications is interpreted as follows:

- The fuel pump is directly driven in an electrical manner, as it is supplied by a power supply system which is directly driven from the crankshaft, self-supplying the system as long as the engine is rotating (as it would be the case on a typical mechanical system).
- From a human factor perspective it is desired, that a main pump may not be switched off inadvertently. This aspect must be resolved per the arrangement of the fuel pump switching system on aircraft level. The arrangement may be such, that the main pump is always ON during flight, while switching OFF is just feasible for fuel pump checking purpose during preflight checks. Prevention of inadvertent operation of switching action is common practice with ignition systems.

BRP-Rotax
INSTALLATION MANUAL

**ENGINE STARTING, START POWER SWITCHING SYSTEM AND
STARTING SYSTEM**

The 915 i A Series engines requires provision of electric power supply for EMS startup (startup power to ECU, sensors, etc.). This is done by a start power switching system (not engine type design), which provides power to the EMS via the Fuse box interface (X3, EMS GND).

The 915 i A Series provides the possibility to supply a starter relay (not engine type design) from the EMS and to actuate the starter relay via the HIC. This arrangement can form a part of a complete starting system with interfaces at the starter, starter relay connector and HIC connector of the engine wiring harness.

When the engine is started the engine internal power supply system Generator B is supplying the EMS. At a certain engine speed , and after a certain amount of stable operating time, the ECU commands power supply system A to take over. power supply system Generator A remains engaged except in the case of failures. This procedure ensures that both power supply systems are checked prior to flight. It is therefore important that a start power switching system releases power prior to commanding power supply system A. This is important so as not to compromise the check of power supply system Generator B.

BRP-Rotax
INSTALLATION MANUAL

LANE SELECT SWITCHING SYSTEM – IGNITION SWITCHING

Certification Specifications might call out specific requirements for ignition systems, whereas this seems to be sometimes driven by classical configurations where the only engine related piece of electronics is represented by the ignition system itself.

The 915 i A Series engine features a complete electronic system including redundant controllers, ignition, injection, power supply, turbo actuation, etc. The ignition system is not to be segregated from the entire system and therefore a classical magneto check needs to be extended to all functions an EECS performs. With the 915 i A Series engines each individual lane (including controller, sensors, actuators) needs to be checked prior to flight, ensuring a full functional check of a system, other than just checking for availability of the ignition system only. This is done by providing a Lane select switching system (not engine type design) to each HIC of the engine system. Ignition switching needs to be interpreted as part of the Lane select switching system which should be in line with the intent of certification specifications.

The two Lane select switching systems are switchable independently (redundant HIC) and just foreseen for engine related functions including ignition. Appropriate separation from other aircraft electrical circuits is required as it might also be defined by aircraft certification specifications. Inadvertent operation of an ignition system needs to be implemented per the design of the Lane select switching system on aircraft level.

BRP-Rotax INSTALLATION MANUAL

FAILURE BEHAVIOR AND WARNING ANNUNCIATION TO THE PILOT

Prediction of pilot action in the case of engine failure is not possible to the engine system designer entirely, since this may vary with actual conditions arising from installation in a specific aircraft (SEP, MEP, type of aircraft, Operational conditions, etc.). It seems more appropriate to provide a detailed description of the engine system behavior in the case of failures to empower the installer to derive pilot action related to the current installation situation. It must be noted that the information provided in the following section is an extract of supposable failure scenarios with the intention to just indicate information relevant to the installer.

The EMS comprises redundant controllers (ECU) which facilitate different system modes. These system modes are Auto_AB which is the common operation mode and Auto_A, Auto_B, Only_A, Only_B, which are alternate system modes. The alternate system modes are engaged either during pre-flight checks or during presence of faults/failures. It is important to understand that each mode is capable providing full control over the engine, respectively providing full power/thrust from the engine. The control modes just differ in efficiency of engine operation.

The ECU distinguishes between fault and failures, whereas a fault prescribes a scenario of low severity, not causing system mode change. A failure leads to a system mode change. The presence of a fault is indicated by a flashing warning lamp. The presence of a failure is indicated by warning lamp which is permanent on. Each individual Lane is equipped with a warning lamp.

The system is equipped with a redundant Display CAN interface for annunciation of a broad range of engine data additionally.

BRP-Rotax
INSTALLATION MANUAL

SIMPLIFIED EMS MATRIX 915 I A SERIES

Item (Failure/Fault)	System	Affect-ed Lane	Warn-ing Lamp A	Warning Lamp B	System Mode	Engine effect
Crankshaft Position Sensor (CPS)	Sensor	A	ON	OFF	Auto_B	No change of engine power; single ignition and single injection
Crankshaft Position Sensor (CPS)	Sensor	B	OFF	ON	Auto_A	No change of engine power; single ignition and single injection
Manifold Air Pressure Sensor (MAPS)	Sensor	A	ON	OFF	Auto_B	No change of engine power; single ignition and single injection
Manifold Air Pressure Sensor (MAPS)	Sensor	B	OFF	ON	Auto_A	No change of engine power; double ignition and single injection
Manifold Air Temperature Sensor (MATS)	Sensor	A	ON	OFF	Auto_B	No change of engine power; single ignition and single injection
Manifold Air Temperature Sensor (MATS)	Sensor	B	OFF	ON	Auto_A	No change of engine power; double ignition and single injection
Throttle Position	Sensor	A	flashing	OFF	Auto_AB	No change of engine power; double ignition and single injection
Throttle Position (in range failure)	Sensor	A	ON	OFF	Auto_B	No change of engine power; single ignition and single injection
Ambient Air Pressure Sensor (AAPS)	Sensor	A	ON	OFF	Auto_B	No change of engine power; single ignition and single injection
Ambient Air Pressure and Temperature Sensor (AAPTS)	Sensor	A	ON	OFF	Auto_B	No change of engine power; single ignition and single injection

BRP-Rotax
INSTALLATION MANUAL

Item (Failure/Fault)	System	Affect-ed Lane	Warn-ing Lamp A	Warning Lamp B	System Mode	Engine effect
Ambient Air Temperature	Sensor	A	flashing	OFF	Auto_AB	No change of engine power; double ignition and single injection
Coolant Temperature Sensor (CTS)	Sensor	A	flashing	OFF	Auto_AB	No change of engine power; double ignition and single injection
EGT (1-4)	Sensor	A	flashing	OFF	Auto_AB	No change of engine power; double ignition and single injection
Knock	Sensor	A	flashing	OFF	Auto_AB	No change of engine power; double ignition and single injection
Display CAN A	Annun-ciation	A	OFF	OFF	Auto_AB	No change of engine power; double ignition and single injection
Display CAN B	Annun-ciation	B	OFF	OFF	Auto_AB	No change of engine power; double ignition and single injection
Maintenance CAN Lane A	Data Bus	A	OFF	OFF	Auto_AB	No change of engine power; double ignition and single injection
Maintenance CAN Lane B	Data Bus	B	OFF	OFF	Auto_AB	No change of engine power; double ignition and single injection
Coil 1/3	Actua-tor	A	ON	OFF	Auto_B	No change of engine power; single ignition and single injection
Coil 2/4	Actua-tor	B	OFF	ON	Auto_A	No change of engine power; single ignition and single injection; Double ignition control mode intended in Auto_A but one ignition failed, therefore single ignition in effect
Injector 1/2/3/4 (INJ)	Actua-tor	A	ON	OFF	Auto_B	No change of engine power; single ignition and single injection

APPENDIX

BRP-Rotax
INSTALLATION MANUAL

Item (Failure/Fault)	System	Affect-ed Lane	Warn-ing Lamp A	Warning Lamp B	System Mode	Engine effect
Injector 5/6/7/8 (INJ)	Actua-tor	B	OFF	ON	Auto_A	No change of engine power; double ignition and single injection
Warning Lamp (WL)	Annun-ciation	A	OFF	OFF	Auto_AB	No change of engine power; double ignition and single injection; Check immediately with display or during next engine start (Warning lamp check)
Warning Lamp (WL)	Annun-ciation	B	OFF	OFF	Auto_AB	No change of engine power; double ignition and single injection; Check immediately with display or during next engine start (Warning lamp check)
Oil Temperature Sensor (OTS)	Sensor	B	OFF	flashing	Auto_AB	No change of engine power; double ignition and single injection
Oil Pressure Sensor (OPS)	Sensor	B	OFF	flashing	Auto_AB	No change of engine power; double ignition and single injection
Loss of EMS Ground Port	Power Supply	A	ON	OFF *(ON)	Only_B	No change of engine power; single ignition and single injection *) if system electric fuel pump supply is used the following applies: No change of engine power; single ignition and single injection if both fuel pumps are ON (Take-off/Landing procedure)
Loss of EMS Ground Port	Power Supply	B	OFF	ON	Only_A	No change of engine power; single ignition and single injection
Power Supply ECU Lane A	Power Supply	A	ON	OFF	Only_B	No change of engine power; single ignition and single injection
Power Supply ECU Lane B	Power Supply	B	OFF	ON	Only_A	No change of engine power; single ignition and single injection

BRP-Rotax
INSTALLATION MANUAL

Item (Failure/Fault)	System	Affect-ed Lane	Warn-ing Lamp A	Warning Lamp B	System Mode	Engine effect
Generator Selector	Power Supply	-	flashing	flashing	Auto_AB	No change of engine power; double ignition and single injection; Automatic switch from Generator A to Generator B, no charging of aircraft battery if Generator B is the only charging source
Generator A	Power Supply	-	flashing	flashing	Auto_AB	No change of engine power; double ignition and single injection; ECU performs automatic change to Generator B; in addition check via display and/or current gauge; no charging of aircraft battery if Generator B is the only charging source
Generator B	Power Supply	-	OFF	OFF	Auto_AB	No change of engine power; double ignition and single injection; no charging of aircraft battery if Generator B is the only charging source. Additional description: In common operation both ECU Lanes monitor the active power supply system, in this case System A (Generator A). Important: ECU does not recognize power supply system B failure in this common operating state. Check is done during next engine start. Immediate check can be done with Ampere/Voltage indication in aircraft.
Rectifier regulator A	Power Supply	-	flashing	flashing	Auto_AB	No change of engine power; double ignition and single injection; ECU performs automatic change to Generator B; in addition check via display and/or current gauge; no charging of aircraft battery if Generator B is the only charging source

APPENDIX

BRP-Rotax
INSTALLATION MANUAL

Item (Failure/Fault)	System	Affect-ed Lane	Warn-ing Lamp A	Warning Lamp B	System Mode	Engine effect
Rectifier regulator B	Power Supply	-	OFF	OFF	Auto_AB	No change of engine power; double ignition and single injection; no charging of aircraft battery if Generator B is the only charging source. See additional description "Generator B".
Specific Failures within Fusebox (Capacitors, Fuses, Relays...) leading to Generator change (to Generator B)	Power Supply	-	flashing	flashing	Auto_AB	No change of engine power; double ignition and single injection; ECU performs automatic change to Generator B; in addition check via display and/or current gauge; no charging of aircraft battery if Generator B is the only charging source
Specific Failures within Fusebox (Capacitors, Fuses, Relays...) leading to loss of electric power supply system Generator B	Power Supply	-	OFF	OFF	Auto_AB	No change of engine power; double ignition and single injection; no charging of aircraft battery if Generator B is the only charging source. See additional description "Generator B".
Boost Pressure Sensor (BPS)	Sensor	A	ON	OFF	Auto_B	No change of engine power; single ignition and single injection
Boost Pressure Sensor (BPS)	Sensor	B	OFF	ON	Auto_A	No change of engine power; double ignition and single injection
Ambient Air Pressure Sensor (AAPS)	Sensor	B	OFF	ON	Auto_A	No change of engine power; double ignition and single injection
Pressure Control Valve (PCV)	Actuator	A	ON	OFF *(ON)	Auto_B	No change of engine power; single ignition and single injection; *) 915 iSc A provides electric power supply to PCV and

BRP-Rotax
INSTALLATION MANUAL

Item (Failure/ Fault)	System	Affect- ed Lane	Warn- ing Lamp A	Warning Lamp B	System Mode	Engine effect
						main fuel pump from same fuse box output. If system electric fuel pump supply is used and power supply to PCV/Main fuel pump fails the following applies: No change of engine power; single ignition and single ignition if both fuel pumps are ON (Take-off / Landing procedure) IFSD in cruising if only one fuel pump (Main) is ON >>Normal Emergency Procedure (Engine Re-Start) >> Both WL are activated because of engine stall. WL activation is irrelevant because engine and annunciation stops immediately.
Pressure Control Valve (PCV)	Actua- tor	B	OFF	ON	Auto_A	No change of engine power; double ignition and single injection
Overboost Pressure Control Valve (OBV)	Actua- tor	A	flashing	OFF	Auto_AB	No change of engine power; double ignition and double injection
Lane Select Switch A	Power Supply	A	ON	OFF	Only_B	No change of engine power; single ignition and single injection
Lane Select Switch B	Power Supply	B	OFF	ON	Only_A	No change of engine power; single ignition and single injection
Fuel pump 1 (Main)	Fuel system	-	OFF * (ON)	OFF *(ON)	Auto_AB	No change of engine power; single ignition and single ignition if both fuel pumps are ON (Take-off / Landing procedure) IFSD in cruising if only one fuel pump (Main) is ON >>Normal Emergency Procedure (Engine Re-Start) >> Both WL are activated because of engine stall. WL activation is irrelevant because engine and annunciation

APPENDIX

BRP-Rotax
INSTALLATION MANUAL

Item (Failure/ Fault)	System	Affect- ed Lane	Warn- ing Lamp A	Warning Lamp B	System Mode	Engine effect
						stops immediately. See also dependence of electric power supply associated with PCV.
Fuel pump 2 (Aux)	Fuel system	-	OFF	OFF	Auto_AB	No change of engine power; double ignition and single injection; Check during next engine start
Fuel pump 1 switching system (Main)	Fuel system	-	OFF * (ON)	OFF *(ON)	Auto_AB	No change of engine power; single ignition and single ignition if both fuel pumps are ON (Take-off / Landing procedure) IFSD in cruising if only one fuel pump (Main) is ON >>Normal Emergency Procedure (Engine Re-Start) >> Both WL are activated because of engine stall. WL activation is irrelevant because engine and annunciation stops immediately. See also dependence of electric power supply associated with PCV.
Fuel pump 2 switching system (Aux)	Fuel system	-	OFF	OFF	Auto_AB	No change of engine power; double ignition and single injection; Check during next engine start
Start switching system	Starting system	-	OFF *(flashing)	OFF	Auto_AB	1) If failure occurs during engine run: No change of engine power; double ignition and double injection. *) 915 iSc A provides electric power supply to OBV and starting system from the same fuse box output. If system electric starting supply is used and power supply to OBV / Starting system fails the following applies: additional to 1) OBV fault and WL A flashing
Starter Relay	Starting system	-	OFF	OFF	Auto_AB	No change of engine power; double ignition and double injection; no effect on EMS / ECU; Failure detection at next

BRP-Rotax
INSTALLATION MANUAL

Item (Failure/Fault)	System	Affect-ed Lane	Warn-ing Lamp A	Warning Lamp B	System Mode	Engine effect
						engine start, Engine (Re-) Start not possible.
Start Power Switching System	Power up system	-	OFF	OFF	Auto_AB	No change of engine power (unless windmilling); double ignition and double injection; no effect on EMS / ECU
Battery Back-up Switching System	Backup PS	-	OFF	OFF	Auto_AB	No change of engine power; double ignition and double injection; no effect on EMS / ECU

BRP-Rotax INSTALLATION MANUAL

HYPOTHESIS ON WARNING LAMP EXECUTION IN THE AIRCRAFT

Aircraft Certification Specifications and related guidance call out for lamp indication colors RED in the case of a warning, YELLOW/AMBER in the case of a caution, GREEN in the case of safe operation. Whereas RED calls out for immediate crew action and YELLOW/AMBER indicates degraded conditions without immediate crew action.

For the 915 i A Series the warning lamp color is not mandated in the engine Installation Manual.

As shown in the extract of supposable failure scenarios (see previous sections), the EMS provides an automatic reaction in the case of faults/failures, still producing sufficient power/thrust in a relevant critical flight phase. The transition to an alternate mode does not implicate manual pilot action. The warning annunciation through the warning lamps indicates the state of an individual Lane. Based on these facts the meaning of warning Lamp indication is to be associated with YELLOW/AMBER entirely. The differentiation between flashing and permanent ON can be ignored in a straight forward approach in terms of ease of interpretation.

The indication of a flashing lamp allows for additional differentiation of the failure severity if desired. A warning lamp that is “just flashing” does not lead to a system mode change. This means even in the case of an additional failure the system provides an alternate system mode.

If flashing lamps are not acceptable the flashing must be filtered at the installers discretion.

If the approach described in the previous section is not found to be acceptable (use just YELLOW/AMBER) the warning lamp signals from the ECU will need to be converted at the installers discretion.

BRP-Rotax INSTALLATION MANUAL

SYSTEM AVAILABILITY AND RELIABILITY

In the course of development and certification, the 915 i A Series has been assessed in terms of safety and reliability. The system is essentially single fault tolerant with respect to LOPC/LOTCT. This means there's an existing (small) number of single faults which can lead to LOPC/LOTCT. However, these failure modes in combination with other existing failure modes are in line with the reliability targets on engine level, which is associated with the term "essentially single fault tolerant".

Following systems are beyond the scope of the engine EMS (not Engine Type Design) but are relevant interface considerations in the course of the engine FTA. Therefore probability rates have been budgeted and are provided here within for installation guidance. These budgeted rates represent conservative reliability numbers and should be well achievable.

For 915 i A Series , assuming that electrical/electronic fuel pumps are used and powered from the engine EMS:

FTA Top Event "LOPC – Loss of Power Control"

- "Battery Backup Fault": The budgeted LOPC FTA probability rate is 1E-4 (failure mode description: no or insufficient backup power supply)
- "Lane Select Switching System Fault": The budgeted LOPC FTA probability rate for a single lane select switching system is 1E-4 (failure mode description: no or insufficient power supply through lane select switching system). Two independent lane select switching systems are required
- "Electrical/electronic fuel pump switching system Fault" is 1E-4 (failure mode description: no or insufficient power supply to fuel pump through switching system). Two independent fuel pump switching systems are required

FTA Top Event "ISDE – Inability to shutdown engine"

- "Fuel Shut Off Valve": The budgeted ISDE FTA probability rate is 1E-4 (failure mode description: fuel shut off valve permanent on/open)
- "Electrical/electronic fuel pump switching system fault": The budgeted ISDE FTA probability rate of a single electrical/electronic fuel pump switching system is 1E-4 (failure mode description: fuel pump switching system fails to open). Two independent fuel pump switching systems are required
- "Lane Select switching system fault": The budgeted ISDE FTA probability rate of a single lane select switching system is 1E-4 (failure mode description: lane select switching system fails to open). Two independent lane select switching systems are required

BRP-Rotax
INSTALLATION MANUAL

ELECTRICAL BONDING

The engine's frame/body is connected to the airframe and there is no floating potential all the time.

The EMS GND is electrically isolated during flight. The engine system is not susceptible to, nor a source of electrostatic discharge. The EMS is most likely located aircraft internally and charging activity is expected to be low (static charge increases with air velocity and friction effect). The electrical system provides a finite working resistance (MOhm range) which is electrically dissipative in terms of electrostatic charge. Charging effect is therefore expected to be low if any.

BRP-Rotax
INSTALLATION MANUAL

INTENTIONALLY LEFT
BLANK

BRP-Rotax INSTALLATION MANUAL

Index

A

Abbreviations.....	6
Air cooling interfaces	7
Approval of electric and electronic components	19
Auxiliary equipment.....	5

B

Battery	21
Bypass line.....	10

C

CAN interfaces.....	15
CAN interfaces – 915 I Type C24.....	19
Coarse filter	11
Components.....	13
constant speed propeller.....	8
Control elements.....	22
Conversion table.....	12
Coolant	12
Coolant hoses.....	11
Coolant, Boiling point.....	12
Crankcase pressure measurement.....	3, 19

E

Electrical bonding.....	17
Electrical interfaces	6, 10, 7, 11, 5, 4
Electrical interfaces – 915 I Type C24	12, 10
Electrical interfaces – 916 I Type A	6
Engine starting, Start power switching system and Starting system.....	4
Engine suspension.....	13
Engine, Handling.....	5
Engine, Preservation	4
Engine, Storage	4
Engine, Unpacking	5
Exhaust tail pipe.....	5
Expansion tank	11

F

Failure behavior and Warning annunciation to the pilot.....	6
Filling and purging the oil system.....	16

Fine filter	11
Fuel interfaces	6
Fuel lines.....	10
Fuel pressure regulator.....	12
Fuel pressure sensor.....	12
Fuel pump	12
Fuel pump Switch.....	20
Fuel pumps and power supplies	3
Fuel shut off valve	13
Fuel system, overview	9
Fuel tank	12

G

Gascolator.....	11
General.....	2
Grounding cables.....	20

H

Handling the engine	7
Hypothesis on warning lamp execution in the aircraft	15

I

Inlet line.....	10
Installation notes	20, 8, 14
Installation overview	20, 11, 10, 16, 18, 13, 14, 6
Installation overview – 915 I Type C24	16
Instruction	16
Interface description	6, 12, 9, 6, 4
Interface overview	4, 6, 10, 5, 4, 8
Interface overview – 915 I Type C24	9
Interface overview.– 915 I Type C24	12

L

Lane Select Switch.....	20
Lane select switching system – Ignition switching	5
List of effective pages	1

M

Measuring of the vacuum.....	5
Mechanical interfaces.....	11, 6, 9, 7, 14, 8

BRP-Rotax

INSTALLATION MANUAL

Mechanical interfaces – 915 I Type C24	18	Simplified EMS Matrix 915 i Series	7
O		Start switch	20
Oil hose, Requirements	7	Starter relay, Technical data	9
Oil lines	14	System availability and reliability	16
Oil pressure sensor	1	System description	4, 3, 5
Oil pump	11	System Description	3
Oil radiator	15	System limitations	4, 3, 6, 3, 5, 4, 3
Oil tank	10	System Limitations	3
Operational and Installation Considerations	1	T	
P		Table of amendments	1
Pneumatic interfaces	8	Technical documentation	17
Positive terminal	4	Terms	6
Propeller governor, hydraulic	8	Type description	3
Purging line, Requirements	7	V	
R		Validation of installation	26, 13, 19, 11
Return line	10	W	
RTCA/DO-160	19	Warning lamp	15
S		Warning lamp – 915 I Type C24	19
Safety	13	Water inlet elbow	11
Safety information	14	Water inlet, Water outlet	5
Scope	2	Water trap	11
Scope of supply	4	Wiring	7
		Wiring color codes	11
		Wiring diagrams	1

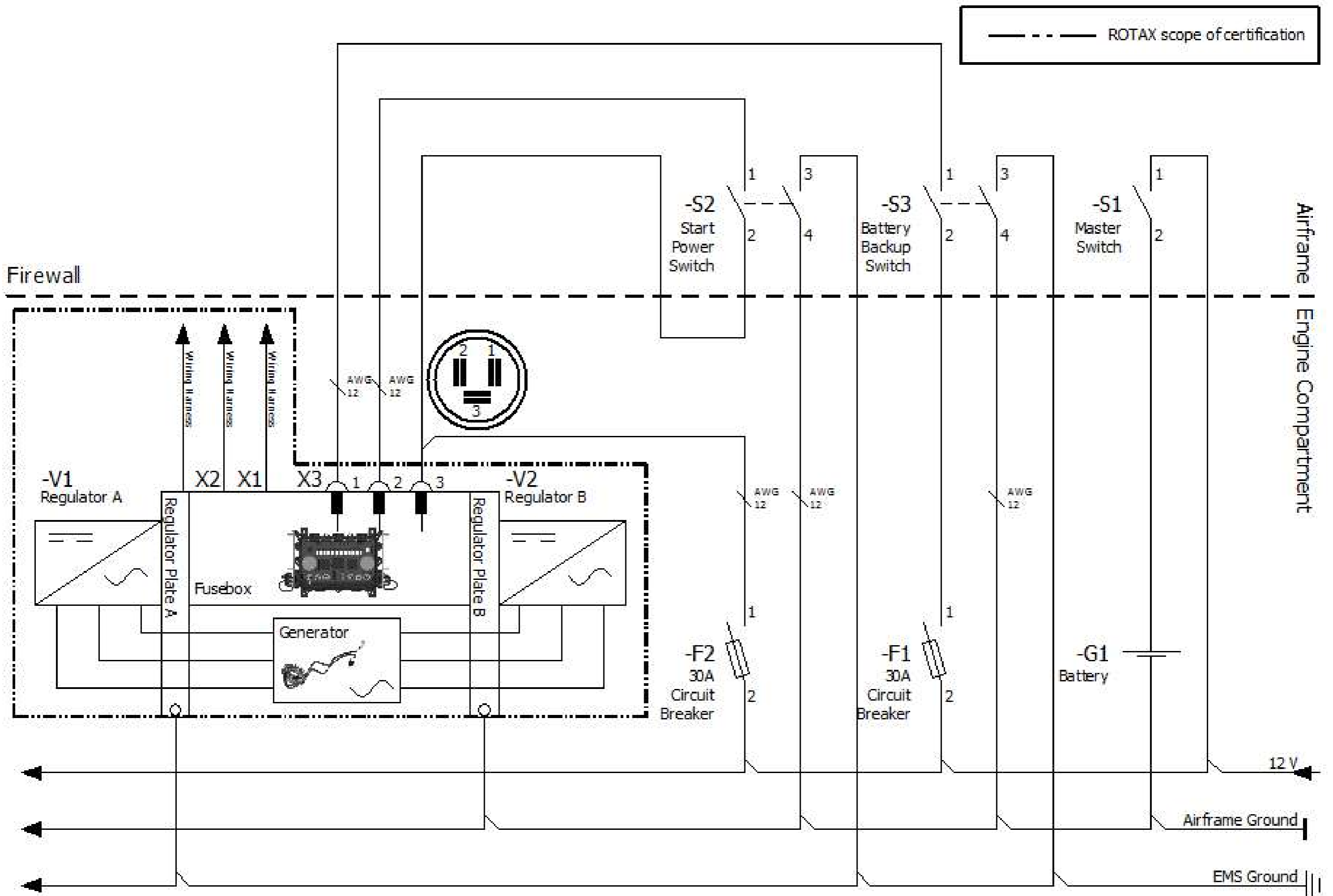

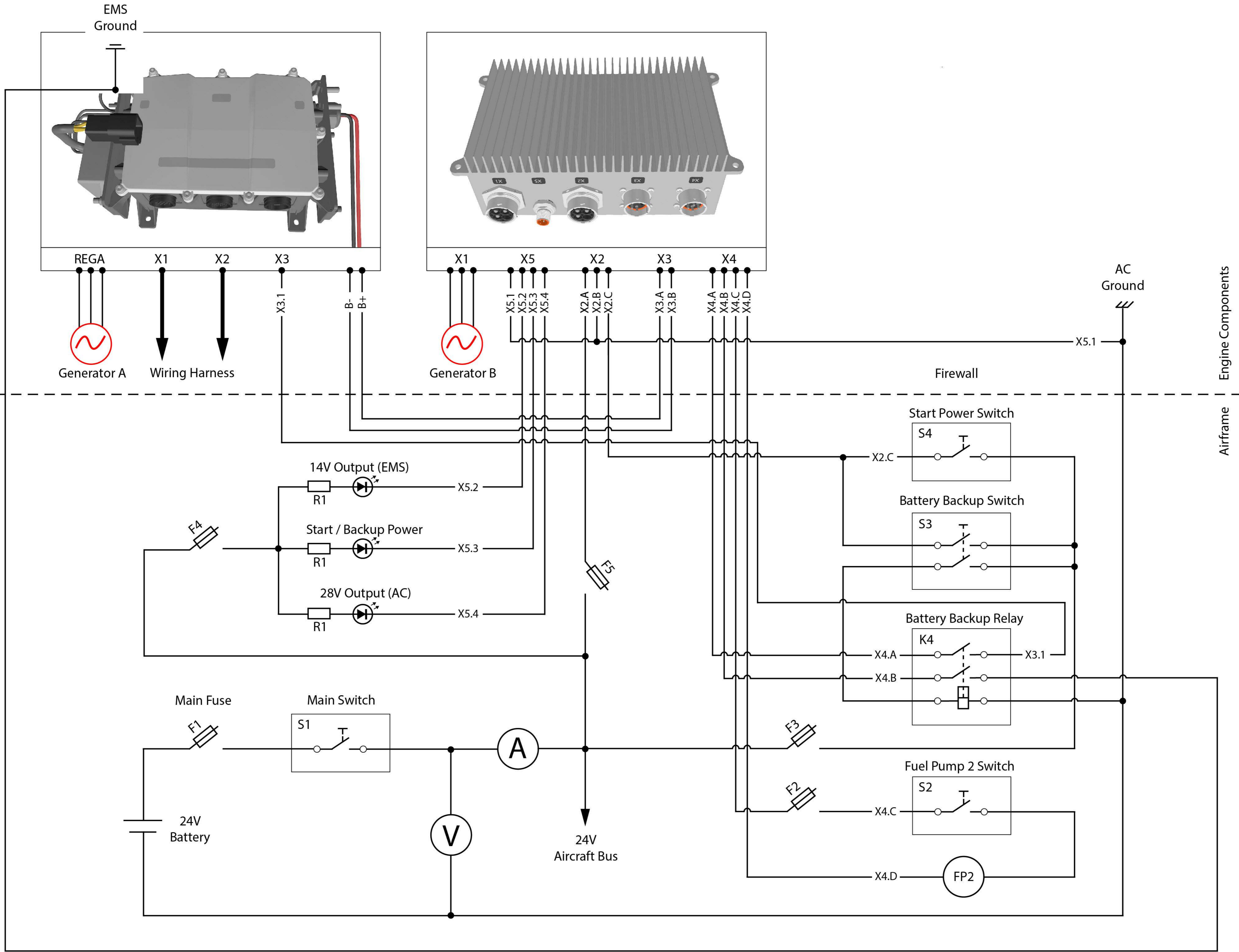

ROTAX®

Engine serial no.

Type of aircraft

Aircraft registration no.

Rotax® authorized distributor

FLYROTAX.COM

® and TM are trademarks of BRP-Rotax GmbH & Co KG.

© 2024 BRP-Rotax GmbH & Co KG. All rights reserved.

