

ROTAX

INSTALLATION MANUAL

FOR ROTAX ENGINE TYPE 912 SERIES

REF NO.: IM-912 | PART NO.: 898644



WARNING

Before starting with engine installation, please read the Installation Manual completely as it contains important safety relevant information.

This Installation Manual for the ROTAX® aircraft engines should only be used as a general installation guide for the installation of ROTAX® engines into airframes. It should not be used as instruction for the installation of a ROTAX® aircraft engine in a specific type of airframe or airplane. BRP-Rotax GmbH & Co KG does not assume any warranty or liability in this context.

In no event shall the Installation Manual be used without following the specific instructions and/or requirements of the manufacture of an airframe or airplane ("Manufacturer"). For verification and/or for release of the engine installation, the respective Manufacturer must be contacted. Any modifications or adaptations to the airframe or airplane shall be carried out and/or be verified and released by the Manufacturer only.

Improper use of the Installation Manual and/or non compliance with the installation requirements of the Manufacturers can cause personal injury or property damage. BRP-Rotax GmbH & Co. KG disclaims any liability for any and all damage and/or injuries (including death) resulting from the improper

use of Installation Manual and non compliance with the installation requirements of the Manufacturer.

These technical data and the information embodied therein are the property of BRP-Rotax GmbH & CO KG, Austria, acc. BGBl 1984 no. 448, and shall not, without prior written permission of BRP-Rotax GmbH & Co KG, be disclosed in whole or in part to third parties. This legend shall be included on any reproduction of these data, in whole or in part. The Manual must remain with the engine/aircraft in case of sale.

ROTAX® is a trademark of BRP-Rotax GmbH & Co KG. In the following document the short form of BRP-Rotax GmbH & Co KG = BRP-Rotax is used.

Other product names in this documentation are used purely for ease of identification and may be trademarks of the respective company or owner.

Copyright 2021 © - all rights reserved.

Translation into other languages might be performed in the course of language localization but does not lie within ROTAX® scope of responsibility.

In any case the original text in English language and the metric units are authoritative.

BRP-Rotax
INSTALLATION MANUAL

Table of Content

Chapter	INTRO – GENERAL NOTE
Chapter	LEP – LIST OF EFFECTIVE PAGES
Chapter	TOA – TABLE OF AMENDMENTS
Chapter	00–00–00 – GENERAL NOTE
Chapter	10–10–00 – STORAGE AND INSTALLATION
Chapter	24–00–00 – ELECTRICAL POWER
Chapter	61–00–00 – PROPELLER DRIVE
Chapter	72–00–00 – ENGINE
Chapter	72–60–00 – AIR INTAKE SYSTEM
Chapter	73–00–00 – ENGINE – FUEL AND CONTROL
Chapter	75–00–00 – COOLING SYSTEM
Chapter	76–00–00 – ENGINE CONTROLS
Chapter	78–00–00 – EXHAUST SYSTEM
Chapter	79–00–00 – LUBRICATION SYSTEM
Chapter	80–00–00 – STARTING

BRP-Rotax
INSTALLATION MANUAL

INTENTIONALLY LEFT
BLANK

BRP-Rotax
INSTALLATION MANUAL

Chapter: INTRO
GENERAL NOTE

Foreword

Before carrying out engine installation related work on the engine, read this Installation Manual carefully. The manual will provide you with basic information on correct engine installation for safe engine operation.

If any passages of the manual are not clearly understood or if you have any questions, please contact a ROTAX® authorized distributor or their independent Service Center for ROTAX® aircraft engines.

BRP-Rotax GmbH & Co KG (hereinafter "BRP-Rotax") wishes you much pleasure and satisfaction flying your aircraft powered by this ROTAX® aircraft engine.

The structure of the manual follows, whenever possible, the structure of the ATA (Air Transport Association) standards. The aim is the compatibility with the aircraft manufacturers documentation, which means they still must adapt or incorporate the documentation to their standard.

BRP-Rotax
INSTALLATION MANUAL

INTENTIONALLY LEFT
BLANK

BRP-Rotax
INSTALLATION MANUAL

Chapter: LEP
LIST OF EFFECTIVE PAGES

Chapter	Page	Date
	Cover page	
INTRO	1	January 01 2021
	2	January 01 2021
LEP	1	January 01 2021
	2	January 01 2021
	3	January 01 2021
	4	January 01 2021
TOA	1	January 01 2021
	2	January 01 2021
00-00-00	1	January 01 2021
	2	January 01 2021
	3	January 01 2021
	4	January 01 2021
	5	January 01 2021
	6	January 01 2021
	7	January 01 2021
	8	January 01 2021
	9	January 01 2021
	10	January 01 2021
	11	January 01 2021
	12	January 01 2021
	13	January 01 2021
	14	January 01 2021
	15	January 01 2021
	16	January 01 2021
	17	January 01 2021
	18	January 01 2021

Chapter	Page	Date
10-10-00	1	January 01 2021
	2	January 01 2021
	3	January 01 2021
	4	January 01 2021
	5	January 01 2021
	6	January 01 2021
	7	January 01 2021
	8	January 01 2021
	9	January 01 2021
	10	January 01 2021
	11	January 01 2021
	12	January 01 2021
	13	January 01 2021
	14	January 01 2021
24-00-00	1	January 01 2021
	2	January 01 2021
	3	January 01 2021
	4	January 01 2021
	5	January 01 2021
	6	January 01 2021
	7	January 01 2021
	8	January 01 2021
	9	January 01 2021
	10	January 01 2021
	11	January 01 2021
	12	January 01 2021
	13	January 01 2021

BRP-Rotax
INSTALLATION MANUAL

Chapter	Page	Date	
	14	January 01 2021	
	15	January 01 2021	
	16	January 01 2021	
	17	January 01 2021	
	18	January 01 2021	
	19	January 01 2021	
	20	January 01 2021	
	21	January 01 2021	
	22	January 01 2021	
	61-00-00	1	January 01 2021
		2	January 01 2021
		3	January 01 2021
		4	January 01 2021
	5	January 01 2021	
	6	January 01 2021	
	7	January 01 2021	
	8	January 01 2021	
72-00-00	1	January 01 2021	
	2	January 01 2021	
	3	January 01 2021	
	4	January 01 2021	
	5	January 01 2021	
	6	January 01 2021	
	7	January 01 2021	
	8	January 01 2021	
	9	January 01 2021	
	10	January 01 2021	
	11	January 01 2021	
	12	January 01 2021	
	13	January 01 2021	

Chapter	Page	Date	
	14	January 01 2021	
	72-60-00	1	January 01 2021
		2	January 01 2021
		3	January 01 2021
		4	January 01 2021
		5	January 01 2021
		6	January 01 2021
		7	January 01 2021
		8	January 01 2021
		9	January 01 2021
		10	January 01 2021
		11	January 01 2021
		12	January 01 2021
73-00-00	1	January 01 2021	
	2	January 01 2021	
	3	January 01 2021	
	4	January 01 2021	
	5	January 01 2021	
	6	January 01 2021	
	7	January 01 2021	
	8	January 01 2021	
	9	January 01 2021	
	10	January 01 2021	
	11	January 01 2021	
	12	January 01 2021	
	13	January 01 2021	
	14	January 01 2021	
	15	January 01 2021	
	16	January 01 2021	
	17	January 01 2021	

BRP-Rotax
INSTALLATION MANUAL

Chapter	Page	Date
	18	January 01 2021
	19	January 01 2021
	20	January 01 2021
	21	January 01 2021
	22	January 01 2021
75-00-00	1	January 01 2021
	2	January 01 2021
	3	January 01 2021
	4	January 01 2021
	5	January 01 2021
	6	January 01 2021
	7	January 01 2021
	8	January 01 2021
	9	January 01 2021
	10	January 01 2021
	11	January 01 2021
	12	January 01 2021
	13	January 01 2021
	14	January 01 2021
	15	January 01 2021
	16	January 01 2021
	17	January 01 2021
	18	January 01 2021
	19	January 01 2021
	20	January 01 2021
	21	January 01 2021
	22	January 01 2021
	23	January 01 2021
	24	January 01 2021
	25	January 01 2021

Chapter	Page	Date
	26	January 01 2021
	27	January 01 2021
	28	January 01 2021
76-00-00	1	January 01 2021
	2	January 01 2021
	3	January 01 2021
	4	January 01 2021
	5	January 01 2021
	6	January 01 2021
	7	January 01 2021
	8	January 01 2021
	9	January 01 2021
	10	January 01 2021
	11	January 01 2021
	12	January 01 2021
	13	January 01 2021
	14	January 01 2021
78-00-00	1	January 01 2021
	2	January 01 2021
	3	January 01 2021
	4	January 01 2021
	5	January 01 2021
	6	January 01 2021
	7	January 01 2021
	8	January 01 2021
	9	January 01 2021
	10	January 01 2021
	11	January 01 2021
	12	January 01 2021
	13	January 01 2021

BRP-Rotax
INSTALLATION MANUAL

Chapter	Page	Date
79-00-00	14	January 01 2021
	1	January 01 2021
	2	January 01 2021
	3	January 01 2021
	4	January 01 2021
	5	January 01 2021
	6	January 01 2021
	7	January 01 2021
	8	January 01 2021
	9	January 01 2021
	10	January 01 2021
	11	January 01 2021
	12	January 01 2021
	13	January 01 2021
	14	January 01 2021
	15	January 01 2021
16	January 01 2021	

Chapter	Page	Date
80-00-00	17	January 01 2021
	18	January 01 2021
	19	January 01 2021
	20	January 01 2021
	21	January 01 2021
	22	January 01 2021
	23	January 01 2021
	24	January 01 2021
	25	January 01 2021
	26	January 01 2021
	27	January 01 2021
	28	January 01 2021
	1	January 01 2021
	2	January 01 2021
	3	January 01 2021
	4	January 01 2021
	Index	
	Rear page	

BRP-Rotax
INSTALLATION MANUAL

Chapter: TOA
TABLE OF AMENDMENTS

Approval*
The technical content of this document is approved under the authority of the DOA ref. EASA.21.J.048.

no.	chapter	page	date of change	remark for approval	date of approval from authorities	date of inclusion	signature
0	INTRO	all	Jan. 01 2021	DOA*			
0	LEP	all	Jan. 01 2021	DOA*			
0	TOA	all	Jan. 01 2021	DOA*			
0	00-00-00	all	Jan. 01 2021	DOA*			
0	10-10-00	all	Jan. 01 2021	DOA*			
0	24-00-00	all	Jan. 01 2021	DOA*			
0	61-00-00	all	Jan. 01 2021	DOA*			
0	72-00-00	all	Jan. 01 2021	DOA*			
0	72-60-00	all	Jan. 01 2021	DOA*			
0	73-00-00	all	Jan. 01 2021	DOA*			
0	75-00-00	all	Jan. 01 2021	DOA*			
0	76-00-00	all	Jan. 01 2021	DOA*			
0	78-00-00	all	Jan. 01 2021	DOA*			
0	79-00-00	all	Jan. 01 2021	DOA*			
0	80-00-00	all	Jan. 01 2021	DOA*			

BRP-Rotax INSTALLATION MANUAL

Summary of amendments

Summary of the relevant amendments in this context, but without requirement on completeness.

current no.	chapter	page	date of change	comment
0	all	all	January 01 2021	new layout and change of company name, change of text and update of illustrations
0	24-00-00	all	January 01 2021	new text for section "Battery"

BRP-Rotax
INSTALLATION MANUAL

Chapter: 00-00-00
GENERAL NOTE

TOPICS IN THIS CHAPTER

General	2
Type description (912 Series)	3
Scope of supply.....	4
Abbreviations and terms (depending on respective engine type)	6
Wiring color codes	10
Conversion table	11
Safety notice	12
Safety information	13
Instruction	15
Technical documentation.....	16

BRP-Rotax INSTALLATION MANUAL

GENERAL

In this Manual all ROTAX® 912 Series engines are described.

NOTE

ROTAX® 912 Series includes 912 A, 912 F, 912 S, 912 UL, 912 UL and 912 ULS.

Purpose

The purpose of this manual is to provide aircraft manufacturers with technical requirements (e.g. interface descriptions and limitations) that must be adhered to when installing this type of engine into an aircraft or certifying aircraft powered by this engine type. Furthermore it should allow independent ROTAX® Maintenance Technicians (iRMT) to install this engine into an airframe in compliance with the relevant installation and safety instructions provided by the engine manufacturer.

For detailed information related to aircraft and aircraft/engine installation, maintenance, safety or flight operation, consult the documentation provided by the aircraft manufacturer and/or its dealer.

For additional information on engines, their maintenance or parts, you can also contact your nearest ROTAX® authorized Aircraft Engine Distributor or their independent Service Center.

ROTAX Distributors

For ROTAX® Authorized Distributors for aircraft engines see latest Operators Manual or the official website www.FLYROTAX.com.

Engine serial number

When making inquiries or ordering parts, always indicate the engine serial number. Due to continuous product improvement, engines of the same engine type might require different support and spare parts. The engine serial number (1) is on the ignition cover, on the left, opposite the electric starter.

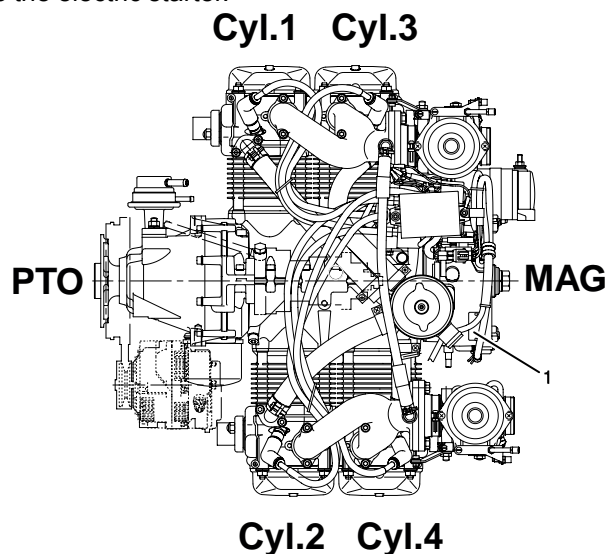

Figure 1.1: 912 Engine serial number

1 Engine serial number

BRP-Rotax INSTALLATION MANUAL

TYPE DESCRIPTION (912 SERIES)

The type description consists of the following:

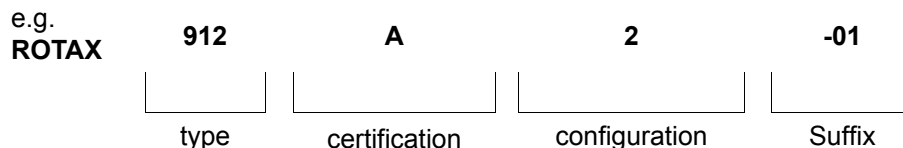

Designation

Designation		Description
Type	912	4 –cyl. horizontally opposed, normal aspirated engine
Certification	A	Certified to JAR 22 (TC No. EASA.E.121)
	F, S	Certified to FAR 33 (TC No. E00051 EN) JAR-E (TC No. EASA.E.121)
	UL, ULS	Non-certified aircraft engines
Configuration	2	Prop shaft with flange for fixed pitch propeller.
	3	Prop shaft with flange for constant speed propeller and drive for hydraulic governor for constant speed propeller.
Suffix	-XX	Explanation of the type designation suffix, see SB-912-068

Options

Available options (optional equipment) for the engine type mentioned above:

	external alternator	vacuum pump	drive for rev counter/ hour meter	governor
for configuration 2	yes	yes	yes	no
for configuration 3	yes	no	yes	yes

NOTE

Conversion of the configuration 2 to configuration 3 may be accomplished by ROTAX® authorized aircraft engines distributors or their Independent service centers.

BRP-Rotax

INSTALLATION MANUAL

SCOPE OF SUPPLY

- Basic**
- 4 stroke, 4 cyl. horizontally opposed, spark ignition engine, single central camshaft hydraulic tappets - push rods - OHV (Over Head Valve)
 - Liquid cooled cylinder heads
 - Ram air cooled cylinders
 - Dry sump forced lubrication
 - Dual ignition of breakerless, capacitor discharge design
 - 2 constant depression carburetors
 - Mechanical fuel pump
 - Electric starter (12 V 0.7 kW), 912 S/ULS (12 V 0.9 kW)
 - Integrated AC generator with external rectifier regulator
 - Propeller drive via integrated gearbox with mechanical shock absorber and overload clutch

NOTE

The overload clutch is installed on all serial production aircraft engines which are certified and non-certified aircraft engines of the configuration 3.

Optional

- Electric starter (12 V 0.9 kW)
- External alternator (12 V 40 A DC)
- Vacuum pump drive
- Hydraulic constant speed propeller governor drive

NOTE

The following equipment is not included as part of the standard engine version!

ATTENTION

Any equipment not included as part of the standard engine version is not part of the engine scope of supply. Components especially developed and tested for this engine are readily available at BRP-Rotax.

⚠ WARNING

Non-compliance can result in serious injuries or death!
The furnishing of proof in accordance to the latest FAR and EASA, has to be conducted by the aircraft manufacturer.

BRP-Rotax INSTALLATION MANUAL

Auxiliary equipment tested

The following auxiliary equipment has been developed and tested for this engine.

- Airbox
- External alternator
- Engine suspension frame
- Vacuum pump (feasible on configuration 2)
- Drive for rev counter/hour meter
- Oil cooler with connections
- Coolant radiator
- Coolant overflow bottle

⚠ WARNING

Non-compliance can result in serious injuries or death!

The user has to assume all risks possibly arising from utilizing auxiliary equipment.

⚠ WARNING

Non-compliance can result in serious injuries or death!

The furnishing of proof in accordance to the latest FAR and EASA, has to be conducted by the aircraft manufacturer.



Auxiliary equipment not tested

The following auxiliary equipment has “not” been developed and tested for this engine.

- Exhaust system
- Intake filter
- Mechanical rev counter
- Electric rev counter
- Shock mount

BRP-Rotax
INSTALLATION MANUAL

ABBREVIATIONS AND TERMS (DEPENDING ON RESPECTIVE ENGINE TYPE)

Abbreviations	Description
*	Reference to another section
	center of gravity
	The drop symbol indicates use of sealing agents, adhesives or lubricants (only in the Maintenance Manual Heavy)
°C	Degrees Celsius (Centigrade)
°F	Degrees Fahrenheit
rpm	Revolutions per minute
A	Ampere
AAPTS	Ambient Air Pressure Temperature Sensor
AC	alternating current
AD	Airworthiness Directives
Ah	Ampere hour
A/C	Aircraft
AR	as required
assy.	assembly
ASB	Alert Service Bulletin
ACG	Austro Control GmbH
ACL	Anti Collision Light
API	American Petrol Institute
ASTM	American Society for Testing and Materials
ATA	Air Transport Association
AWG	American Wire Gauge
CAN	Controller Area Network
CCS	Camshaft position sensor
Coil 1-4	Ignition coils 1-4
CPS 1+2	Crankshaft Position Sensor 1+2
CSA	Constant Speed Actuator
CTS	Cooling Temperature Sensor
CW	clockwise

BRP-Rotax INSTALLATION MANUAL

Abbreviations	Description
CCW	counter-clockwise
CGSB	Canadian General Standards Board
DCDI	Dual Capacitor Discharge Ignition
DC	direct current
DOA	Design Organisation Approval
DOT	Department of Transport
EASA	European Aviation Safety Agency
IM	Installation Manual
ECU	Engine Control Unit
EGT	Exhaust Gas Temperature
INTRO	Introduction
EMS	Engine Management System
EMS GND	Engine system internal ground reference which is intended to be disconnected from aircraft common ground during flight
EMC	Electromagnetic compatibility
EN	European Standard
ETFE	Ethylene Tetrafluoroethylene
FAA	Federal Aviation Administration
FAR	Federal Aviation Regulations
FOD	Foreign object damage
Fuse box	Power conditioning and distribution for the Engine Management System
hr.	hours
HIC A	Harness Interface Connector A
HIC B	Harness Interface Connector B
IAT	Indicated Air Temperature
ICA	Instructions for Continued Airworthiness
IFR	Instrument Flight Rules
IFSD	In-flight-shutdown
INJ 1–8	Injector 1–8
IPC	Illustrated Parts Catalog
ips	inch per second

BRP-Rotax INSTALLATION MANUAL

Abbreviations	Description
iRMT	independent ROTAX Maintenance Technician
ISA	International Standard Atmosphere
kg	Kilograms
KNOCK	Knock sensor
Lane A	System A of Engine Management System
Lane B	System B of Engine Management System
LOPC	Loss of power control
MAPS 1 & 2	Manifold Air Pressure Sensor 1 & 2
MATS 1 & 2	Manifold Air Temperature Sensor 1 & 2
MON	Motor Octane Number
MAG	Magneto Side
N	Newton
n.a.	not available
NDT	Non Destructive Testing
Nm	Newtonmeter
NVFR	Night Visual Flight Rules
OAT	Outside Air Temperature
OHM	Overhaul Manual
OHV	Over Head Valve
OM	Operators Manual
OPS	Oil Pressure Sensor
OTS	Oil Temperature Sensor
PCD	Pitch Circle Diameters
PCV	Pressure Control Valve
PMA	Permanent magnet alternator
POA	Production Organisation Approval
PS	Power supply
PTFE	Polytetrafluoroethylene (Teflon)
PTO	Power Take Off
Rev.	Revision
ROTAX®	is a trademark of BRP-Rotax GmbH & Co KG















BRP-Rotax INSTALLATION MANUAL

Abbreviations	Description
RON	Research Octane Number
RON 424	ROTAX® Standard 424
s.v.	still valid (only Illustrated Parts Catalog)
S/N	Serial Number
SAE	Society of Automotive Engineers
SEP	Single Engine Piston
SB	Service Bulletin
SI	Service Instruction
SI-PAC	Service Instruction Parts and Accessories
SPST	Single pole single throw
STP	Shielded twisted pair
SL	Service Letter
SMD	Surface Mounted Devices
TBO	Time Between Overhaul
TC	Type certificate
part no.	part number
TOA	Table Of Amendments
TOC	Table Of Contents
TPS	Throttle Position Sensor
TSN	Time Since New
TSNP	Time Since New Part
TSO	Time Since Overhaul
V	Volt
VFR	Visual Flight Rules
LEP	List of Effective Pages
MM	Maintenance Manual
MEP	Multi Engine Piston
X3	Connector on Engine Management System wiring harness which serves as an interface for power supply
XXXX	shows the component serial number

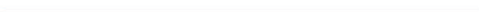
WIRING COLOR CODES

IEC 60757

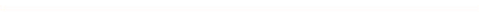
Color codes (wiring)

black		BK
brown		BN
red		RD
orange		OG
yellow		YE
green		GN
blue		BU
violet		VT
gray		GY
white		WH
pink		PK
turquoise		TQ
Light blue		LBU
Dark blue		DBU
gold		GD
silver		SR
green-yellow		GNYE

10336

Figure 1.2

BRP-Rotax
INSTALLATION MANUAL

CONVERSION TABLE

Units of length:	Units of power:
1 mm = 0.03937 in 1 in = 25.4 mm 1 ft = 12 in = 0.3048 m	1 kW = 1.341 hp 1 hp = 0.7457 kW 1 kW = 1.3596 PS 1 PS = 0.7355 kW
Units of area:	Units of temperature:
1 cm ² = 0.155 sq. in (in ²) 1 sq. in (in ²) = 6.4516 cm ²	K = °C – 273,15 °C = (°F – 32) / 1,8 °F = (°C x 1.8) +32
Units of volume:	Units of velocity:
1 cm ³ = 0.06102 cu in (in ³) 1 cu in (in ³) = 16.3871 cm ³ 1 dm ³ = 1 l 1 dm ³ = 0.21997 gal (UK) 1 gal (UK) = 4.5461 dm ³ 1 dm ³ = 0.26417 gal (US) 1 gal (US) = 3.7854 dm ³	1 m/s = 3.6 km/h 1 ft/min = 0.3048 m/min = 0.00508 m/sec 1 m/s = 196.85 ft/min 1 kt = 1.852 km/h 1 km/h = 0.53996 kn
Units of mass:	spec. fuel consumption:
1 kg = 2.2046 lbs. 1 lb. = 0.45359 kg	1 g/kWh = 0.001644 lb/hph 1 lb/hph = 608.277 g/kWh
Density:	Units of torque:
1 g/cm ³ = 0.016018 lb/ft ³ 1 lb/ft ³ = 62.43 g/cm ³	1 Nm = 0.737 ft lb = 8.848 in lb 1 ft lb = 1.356 Nm 1 in lb = 0.113 Nm
Units of force:	Cable cross-section: Conversion table- Wire Gauge: AWG-mm²
1 N = 0.224809 lbf 1 lbf = 4.4482 N	AWG → mm ² 4 → 21 6 → 13 8 → 8.4 10 → 5.3 12 → 3.3 14 → 2.1 16 → 1.3 18 → 0.8 20 → 0.52
Units of pressure:	
1 Pa = 1 N/m ² 1 bar = 100 000 Pa / 1000 hPa / 100 kPa 1 bar = 14.503 lbf/in ² (psi) 1 in Hg = 33.8638 hPa	

BRP-Rotax INSTALLATION MANUAL

SAFETY NOTICE

Although reading such information does not eliminate any hazards, it promotes understanding, and applying of the information will promote correct use of the engine. Always apply common workshop safety rules.

The information and descriptions of components and systems contained in this Manual are correct at the time of publication. BRP-Rotax maintains a policy of continuous improvement of its products without imposing upon itself any obligation to retrofit products previously manufactured.

Revisions

BRP-Rotax reserves the right to remove, replace or discontinue any design, specification, feature or other at any time, and without incurring obligation.

Measurement

Specifications are given in the SI metric system with the imperial- and US customary measurement system equivalents in parenthesis.

Symbols used

This Manual uses the following symbols to emphasize particular information. This information is important and must be observed.

⚠ WARNING

Identifies an instruction which, if not followed, may cause serious injury or even fatal injury.

⚠ CAUTION

Identifies an instruction which, if not followed, may cause minor or moderate injury.

ATTENTION

Identifies an instruction which, if not followed, may severely damage the engine or could void any warranty.

NOTE

Indicates supplementary information which may be needed to fully complete or understand an instruction.

ENVIRONMENTAL NOTE

Environmental notes give you tips on environmental protection.

A revision bar outside the page margin indicates a change to text or graphic.

BRP-Rotax INSTALLATION MANUAL

SAFETY INFORMATION

Use for intended
purpose

⚠ WARNING

Non-compliance can result in serious injuries or death!

The user has to assume all risks possibly arising from utilizing auxiliary equipment.

⚠ WARNING

Non-compliance can result in serious injuries or death!

Never fly the aircraft equipped with this engine at locations, air speeds, altitudes or in other situations which do not allow a successful no-power landing after sudden engine stoppage.

- This engine is not suitable for aerobatics (inverted flight, etc.). Flight attitudes outside the permissible limits are not allowed
- This engine has exclusively been developed and tested for fixed wing, gyrocopter, pusher and tractor applications. In case of any other usage, the OEM is responsible for testing and the correct function of the engine
- It should be clearly understood that the choice, selection and use of this particular engine on any aircraft is at the sole discretion and responsibility of the aircraft manufacturer, assembler or owner/user
- Due to the varying designs, equipment and types of aircraft, BRP-Rotax grants no warranty on the suitability of its engines use on any particular aircraft. Further, BRP-Rotax grants no warranty on this engines suitability with any other part, component or system which may be selected by the aircraft manufacturer, assembler or user for aircraft application

⚠ WARNING

Non-compliance can result in serious injuries or death!

For each use of DAY VFR, NIGHT VFR or IFR in an aircraft the applicable legal requirements and other existing regulations must be adhered to.

- In addition to observing the instructions in our Manual, general safety and accident precautions, legal regulations and regulations of any aeronautical authority must be observed
- Where differences exist between this Manual and regulations provided by any authority, the more stringent regulation shall be applied
- For continued airworthiness see Maintenance Manual Line
- Unauthorized modifications of engine or aircraft will automatically exclude any liability of the engine manufacturer for consequential damage

BRP-Rotax INSTALLATION MANUAL

- This engine may be equipped with a vacuum pump. The safety warning accompanying the air pump must be given to the owner/operator of the aircraft into which the air pump has been installed

Engine operation

- The engine must always be operated according to the content of the latest Operators Manual
- To eliminate the risk of injury or damage, ensure any loose equipment or tools are properly secured before starting the engine
- The use of propellers and their fastenings which exceed the specified values of moment of inertia and imbalance is not allowed and releases the engine manufacturer from any liability
- Improper engine installation, use of unsuitable piping for fuel, cooling and lubrication system and use of unsuitable wiring for electric and engine management system releases the engine manufacturer from any liability

BRP-Rotax INSTALLATION MANUAL

INSTRUCTION

Engines require instructions regarding their installation, application, use, operation, maintenance and repair.

Technical documentation and regulations are useful and necessary complementary elements for trainings, but can by no means substitute for theoretical and practical instructions.

These instructions should cover explanation of the technical context, advice for operation, maintenance, installation, use and operational safety of the engine.

Safety notice

In this technical Manual passages concerning safety are especially marked. Pass on safety warnings to other users!

Accessories

This engine must only be operated with accessories supplied, recommended and released by BRP-Rotax. Modifications are only allowed after consent of the engine manufacturer.

Spare parts



See Illustrated Parts Catalog, latest issue for the respective engine type.

ATTENTION

Only use GENUINE ROTAX® spare parts. Spare parts must meet the requirements defined by the engine manufacturer. This can only be guaranteed when using GENUINE ROTAX® spare parts and/or accessories. Spare parts are available at ROTAX® Authorized Distributors and their independent Service Centers. Any warranty by BRP-Rotax will become void if spare parts and/ or accessories other than GENUINE ROTAX® spare parts and/or accessories are used (see latest Warranty Conditions).

See relevant Service Letter on www.FLYROTAX.com

Standard tools / Special tools

ATTENTION

Only use tools and appliances which are suitable for the relevant task according to the latest Manuals.

State of delivery

⚠ WARNING

Engine and gearbox are delivered in “dry” conditions (without fuel, oil and coolant).

Before putting the engine into operation it must be filled with oil and cooling liquid. Use only oil and coolant as specified.

BRP-Rotax INSTALLATION MANUAL



See latest Operators Manual and Service Instruction SI-912-016 “Selection of suitable operating fluids“, current issue.

TECHNICAL DOCUMENTATION

These documents form the instructions ensuring continued airworthiness of ROTAX® aircraft engines.

The information contained herein is based on data and experience that are considered applicable for authorized mechanics (iRMT, see MML, Chapter 05–00–00 section “Authorized Personnel”) under normal conditions for engine removal and installation. Concerning design of engine installation in depth knowledge of aircraft design is required.

Due to the fast technical progress and fulfillment of particular specifications of the customers it may occur that existing laws, safety prescriptions, constructional and operational regulations may not be sufficient or cannot be transferred completely to the object bought, in particular for special constructions.

Documentation

- Installation Manual
- Operators Manual
- Maintenance Manual (Line and Heavy Maintenance)
- Overhaul Manual
- Illustrated Parts Catalog
- Alert Service Bulletin
- Service Bulletin
- Service Instruction / Service Instruction-Parts and Accessories
- Service Letter



Status

The status of the Manuals can be determined by checking the table of amendments. The first column of this table indicates the revision status, which should be compared with the revision provided on the ROTAX®-Website: www.FLYROTAX.com
Amendments and current versions can be downloaded free of charge.

Replacement pages

Furthermore the Manual is constructed in such a way that single pages can be replaced instead of the complete document. The list of affected pages is given in the chapter LEP. The particular edition and revision number is given on the footer of each page.

Reference

This Manual is only part of the technical documentation and will be supplemented by the respective Operators Manual, Maintenance Manuals and Illustrated Parts Catalog.

BRP-Rotax INSTALLATION MANUAL

ATTENTION

Pay attention to references to other documentation, found in various parts of this Manual.

If not stated otherwise, any reference to a document refers to the latest edition issued by BRP-Rotax.



This symbol informs you of additional references (data sheets, Manuals, etc.) associated with the given subject.

Illustrations

The illustrations in this Manual are merely sketches and show typical arrangements. They may not represent full detail or the exact shape of the parts but should outline the same or similar function. Therefore deriving dimensions or other details from illustrations is not permitted.

TYPICAL indicates a general view which may not represent exact details.

NOTE

The Illustrations in this Manual are stored in a graphic database system and are provided with a consecutive, irrelevant, number.

This number (e.g. AE 5iS001) is of no significance for the content.

Some measurements are given in the drawings, these are manufacturing dimensions and are subject to corresponding tolerances.

Installation drawings

Installation drawings and a DMU-model for (virtual) installation analysis are available from the ROTAX® Authorized Distributors or their independent Service Centers on special request and relevant non disclosure and copyright regulations.

The illustrations in this Manual show a possible installation variant including non certified parts.

BRP-Rotax
INSTALLATION MANUAL

INTENTIONALLY LEFT
BLANK

BRP-Rotax
INSTALLATION MANUAL

Chapter: 10-10-00
STORAGE AND INSTALLATION

TOPICS IN THIS CHAPTER

Preparations for engine installation	2
State of delivery	2
Unpacking the engine	2
Engine storage	4
Engine suspension and installation position.....	5
Engine suspension instructions	5
Mechanical interfaces	6
Permissible installation positions	9
Preparations for trial run of engine.....	12
Checks before trial run	12
Conduct test run.....	13
Verification of the throttle lever for max. continuous power	13

BRP-Rotax INSTALLATION MANUAL

PREPARATIONS FOR ENGINE INSTALLATION

ATTENTION

To prevent any accidents and engine damage.
Observe the stated directives during every engine installation.

STATE OF DELIVERY

ATTENTION

Risk of consequential damage to engine and aircraft as a result of corrosion and damage. Under no circumstances is a corroded or damaged engine to be installed in an aircraft!

ATTENTION

The attachment screws are only for transport and must not be used in the aircraft.

Attachment

The engine can be attached with steel angles anchored on a timber plate.

- When the engine is delivered, check that the GENUINE-ROTAX® packing is not damaged.
- If the packing is damaged, contact the authorized distributor- or their independent Service Center for ROTAX® aircraft engines.

UNPACKING THE ENGINE

ATTENTION

During engine installation take into account the total engine weight and ensure careful handling.

Unpacking the engine

When the engine is delivered, check for damage of the packaging. If the package is damaged, contact the authorized Distributor- or their independent Service Center for ROTAX® aircraft engines.

To unpack a new engine and for checking the state of delivery, proceed as follows:

Step	Procedure
1	Remove the wooden cover.
2	Remove the desiccant bag and protective wrapping around the engine.
3	Check that the serial number and engine type on the type plate are identical to those shown on the delivery note. If the serial number or the engine type is deviating from the delivery contact a ROTAX® Authorized Distributor- or their independent Service Center for ROTAX® aircraft engines.

BRP-Rotax INSTALLATION MANUAL

Step	Procedure
4	Check the engine for damage or corrosion. If the engine is damaged or corroded, contact a ROTAX® Authorized Distributor- or their independent Service Center for ROTAX® aircraft engines.
5	Unscrew the transport bracket screws from wooden bottom of the box.
6	Lift engine using two straps or hooks attached to the intake manifolds.
7	Remove transport brackets from engine.

Protective coverings

ATTENTION
<p>Protective coverings are only for use during transport and engine installation. They must be removed completely (including sealing materials) before the engine is operated.</p>

All openings are protected against ingress of contamination and dampness. It is recommended to leave the protective plugs in place until installation of the specific feed line.

NOTE

The transport equipment and plugs must be reattached if the engine will be sent to the manufacturer or distributor.

The protective coverings can be found at following locations:

Pos.	Installation location	Amount
1	Exhaust sockets	4x cone plug
2	Connection for manifold pressure	1x cap
3	Airbox	2x cap
4	Fuel pump inlet	1x cap
5	Connection for fuel return	1x plug
6	Connection for fuel pressure	1x plug
7	Oil supply and oil discharge	1x each cap
8	Supply and discharge of coolant	1x each cone plug
9	Propeller shaft on configuration 3	1x disk plug
10	Carburetor (if not equipped with an airbox)	2x disk plug
11	Cover (governor flange)	1x cap

BRP-Rotax

INSTALLATION MANUAL

ENGINE STORAGE

The engine is preserved at BRP-Rotax thus guaranteeing proper protection against corrosion damage for at least 12 months after the date of delivery from BRP-Rotax.

This warranty is subject to the following conditions:

- The engine must be stored in the GENUINE ROTAX® packing as supplied by BRP-Rotax.
- The covers on various openings must not be removed
- The engine must be stored in a suitable place (at min. -40 °C/-40 °F and max. +80 °C/176 °F)
- The bag (blue) surrounding the engine must not be damaged or removed, as it protects the engine from corrosion and oxidation

If the engine is stored for a period longer than 12 months (or it is not stored in the GENUINE ROTAX® packing) then maintenance tasks must be carried out every 3 months as per the currently valid Maintenance Manual Line.

BRP-Rotax
INSTALLATION MANUAL

ENGINE SUSPENSION AND INSTALLATION POSITION

ATTENTION

During engine installation take into account the total engine weight and ensure careful handling.

Engine suspension

The engine suspension is essentially determined by the aircraft design. Eight attachment points are provided (4 on the engine and 4 on the engine suspension frame).

Engine suspension frame

If the engine suspension frame is not used or if modified:

⚠ WARNING

Non-compliance can result in serious injuries or death!

The furnishing of proof in accordance to the latest FAR and EASA, has to be conducted by the aircraft manufacturer.

The engine is supplied with a tested and certified suspension frame for the fireproof bulkhead. Installation in the aircraft is carried out using captive rubber mounts which also isolate vibration and noise from the aircraft frame.

ENGINE SUSPENSION INSTRUCTIONS

The rubber mounts for neutralizing vibrations and all engine suspension components not in the scope of delivery must be ground run tested at the specified loads and tested for vibration behavior.

⚠ WARNING

Non-compliance can result in serious injuries or death!

The furnishing of proof in accordance to the latest FAR and EASA, has to be conducted by the aircraft manufacturer.

Noise emission and vibration

ATTENTION

The engine suspension must be designed to prevent excessive engine movement and to minimize noise emission and vibration on the airframe.

ATTENTION

If the GENUINE ROTAX® engine suspension frame is not being used, a vibration test must be carried out.



See Service Letter SL-912-010 "Vibration test", latest issue.

BRP-Rotax INSTALLATION MANUAL

NOTE

With suspension on the 4 top lugs L3, R3, L4 and R4 only, the tilting moment due to the pull of the propeller will be avoided while, if attached on the bottom lugs only, the moment of tilting is taken care of accordingly.

Damping elements

ATTENTION

All elements for neutralizing vibrations must be captive.

Standard aircraft industry damping elements (e.g. Lord) are suitable. The illustration shows Lord J 3608-1 or J 3608-2 rubber mounts.

NOTE

Consult the parts manufacturer for the dimensions of the rubber mounts.

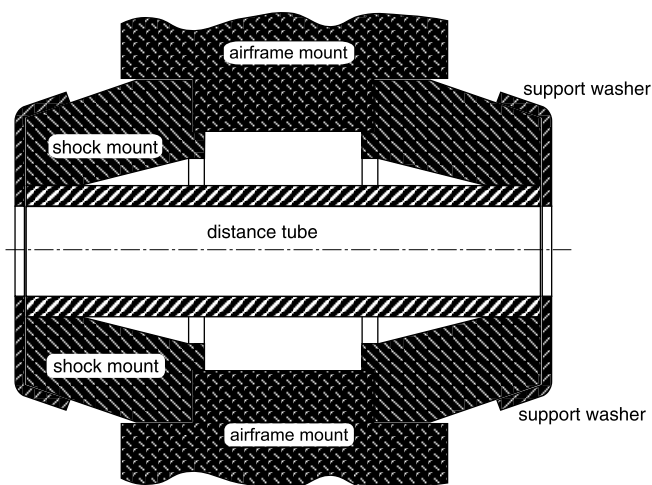

Figure 2.1: Damping element engine suspension

Vibration neutralization

The vibration and acoustic insulation factor is dependent on the aircraft manufacturer. Perform the determination as described in SL-912-010.

MECHANICAL INTERFACES

ATTENTION

A minimum of 4 attachment points must be used. These must be distributed symmetrically between the left (L) and right (R) sides.

It is recommended that the 4 stated attachment points R2, L2, R3 and L3 of the engine suspension frame are used.

BRP-Rotax INSTALLATION MANUAL

⚠ WARNING

Non-compliance can result in serious injuries or death!

The aircraft or fuselage manufacturer must design the engine suspension so that it can safely carry the maximum occurring operational loads without exceeding the max. allowable forces and bending moments on the engine housing and attachment points. Tighten all engine suspension screws as specified by the aircraft manufacturer.

ATTENTION

The attachment screws are only for transport and must not be used in the aircraft.

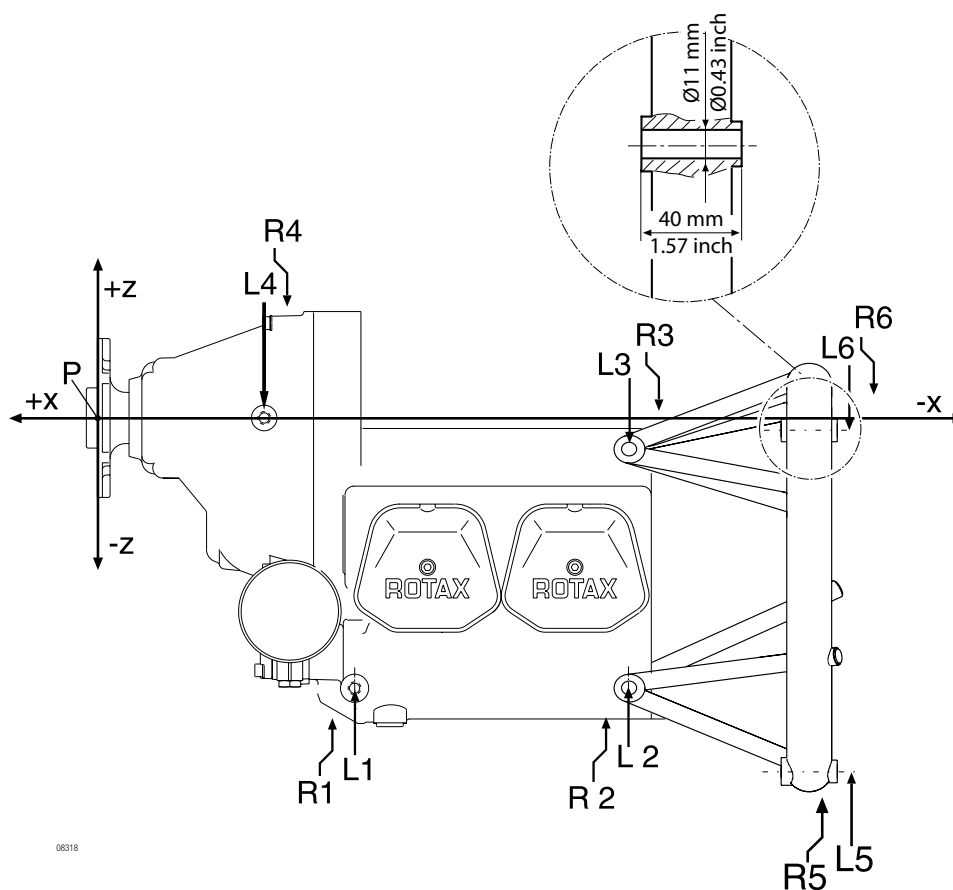

Figure 2.2: Attachment points

BRP-Rotax
INSTALLATION MANUAL

Attachment points	L1	R-1	R-2	L2	L3	R3	L4	R4	L5	R-5	R-6	L6
x-axis [mm / in.]	- 200.7 / -7.90		- 414.3 / -16.31				- 128.3 / -5.05		-564 / -22.20			
y-axis [mm / in.]	-71 / -2.8	-71 / -2.8		71 / 2.8	75 / 2.96	-75 / -2.96	87 / 3.43	-87 / -3.43	105 / 4.13	-105 / -4.13		105 / 4.13
z-axis [mm / in.]	-211 / -8.31				22 / -0.87		0		-277 / -10.91		-7 / -0.28	
max. permissible forces in x axis	5000 N (1124 lbf)						1900 N (427 lbf)		5000 N (1124 lbf)			
max. permissible forces in y axis	5000 N (1124 lbf)						1900 N (427 lbf)		2000 N (450 lbf)			
max. permissible forces in z axis	5000 N (1124 lbf)						1900 N (427 lbf)		3000 N (674 lbf)			
max. permissible bending moment in x, y, z axis	77 Nm (56.8 ft lb)						39 Nm (28.8 ft lb)		100 Nm (73.8 ft lb)			

BRP-Rotax INSTALLATION MANUAL

Thread	M10					
max. usable Thread length	24.9 mm (0.98 in.)	19.3 mm (0.76 in.) ¹	16 mm (0.63 in.) ²			

PERMISSIBLE INSTALLATION POSITIONS

ATTENTION

Upside-down/inverted installation of the engine.

The oil system, fuel system and the cooling system are unsuitable for upside-down/inverted installation of the engine!

NOTE

All distances are given in relation to the reference coordinate system (P).

Installation positions

The following installation position details refer to the aircraft in parked position (aircraft on ground, ready for take off).

- Engine suitable for propeller in tractor or pusher arrangement
- Installation only with propeller shaft above cylinders

Propeller axis

The centres of attachment points L1 and R1 must be on a y2 axis parallel to the y-axis.
Permissible deviation from parallel: $\pm 5^\circ$

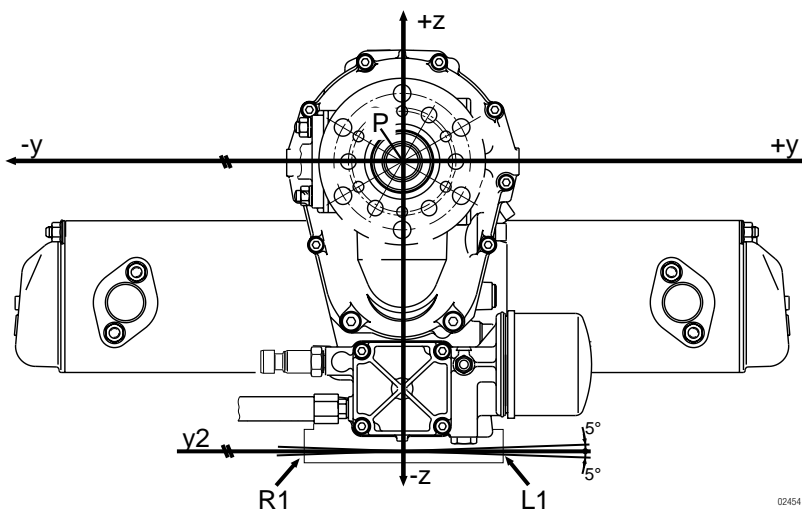

Figure 2.3: Deviation Propeller axis

1. up to S/N 28986
2. starting from gearbox S/N 28987

BRP-Rotax INSTALLATION MANUAL

Longitudinal axis: The centre of the attachment points L1 and L(T)2 must be on axis x2 parallel to the x axis.

Allowable pitch deviation of parallelism of axis:

- on ground
max. 6° counter-clockwise
- in operation
max. 10° counter-clockwise,
- max. 30° clockwise

⚠ WARNING

Non-compliance can result in serious injuries or death!

On installations with fuel tank located above carburetor level combined with badly closing carb float valve, fuel could pass into cylinders at more than 6° decline of propeller shaft axis after longer periods of downtime. See FAR, § 33.17. To avoid a possible gasoline explosion (cylinder full with fuel) at start up, take care of well-closing float needles. In case of doubt, the fuel valve must be closed or the aircraft parked with increasing propeller shaft axis.

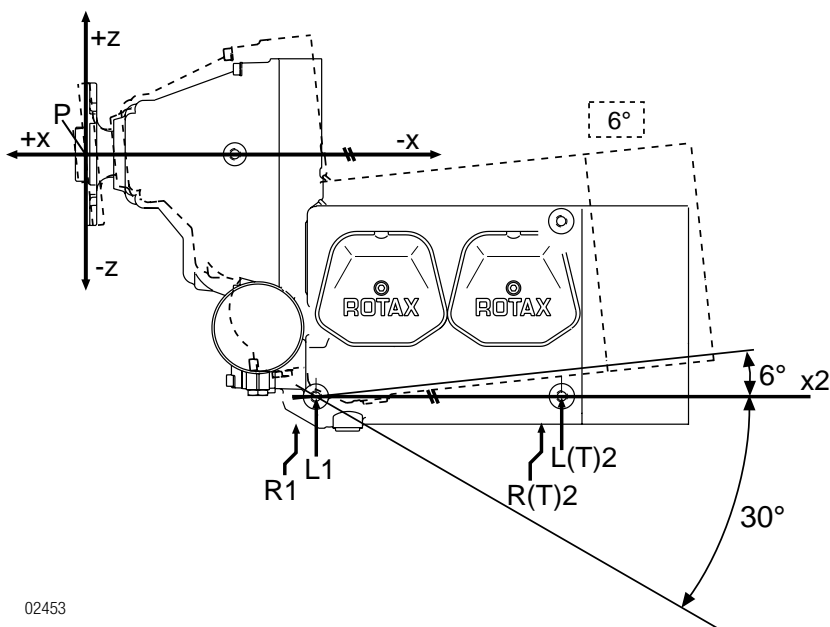

02453

Figure 2.4: Deviation longitudinal axis

BRP-Rotax INSTALLATION MANUAL

Vertical axis

The y-axis must be perpendicular to the longitudinal axis of the aircraft.

Permissible deviation from perpendicular: $\pm 10^\circ$

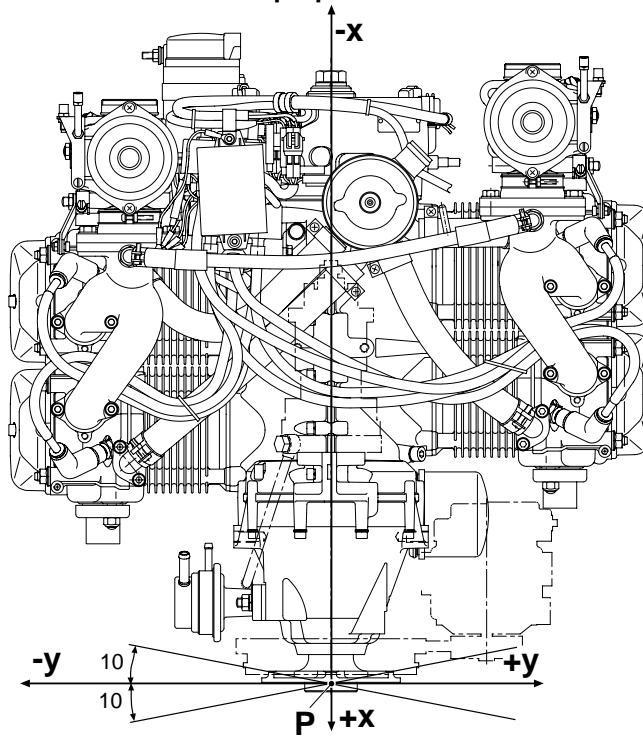

Figure 2.5: Deviation Vertical axis

BRP-Rotax
INSTALLATION MANUAL

PREPARATIONS FOR TRIAL RUN OF ENGINE

⚠ WARNING

Non-compliance can result in serious injuries or death!
Engine start and operation must be observed as described in the Operators Manual.

CHECKS BEFORE TRIAL RUN

⚠ WARNING

Non-compliance can result in serious injuries or death!
Always observe the engine from a safe place while it is running. Check that the cockpit is occupied by a competent operator.

NOTE

This checklist is not exhaustive. Consult all Instructions for Continued Airworthiness.



See latest Operators Manual of the respective engine type.



Review relevant Service Instruction for "Selection of suitable operating fluids" current issue.

- Check engine oil, coolant and fuel level
- Check throttle and choke controls hit both stops and operates in correct range of motion
- Make sure that no tools remain in the engine compartment
- Check for other foreign or loose objects
- Check for tight fit of propeller and pitch setting
- Check that propeller control hits stops and operates on correct range of motion (if equipped)
- Fasten the aircraft to the ground in an appropriate way and use chocks for the wheels. Secure the area surrounding the propeller to exclude hazards to other persons
- Visual inspection of engine and accessories
- Check for leaks
- Check suspension of engine
- Check for a tight fit of oil filter
- Check oil hose connections are correct
- Check for correct oil system purging

BRP-Rotax INSTALLATION MANUAL

- Check if other systems and instruments are installed appropriately
- Check gauges for accuracy
- Check wires routed properly and secured
- Check exhaust system for security and free of blockage
- Preheat engine in cold weather

CONDUCT TEST RUN



See latest Operators Manual of the respective engine type.

⚠ WARNING

Non-compliance can result in serious injuries or death!

The general safety information must be observed for all work on the aircraft engine and its surrounding components.

⚠ WARNING

Non-compliance can result in serious injuries or death!

Proper clothing, ear protection etc. should be used during any engine test run.

VERIFICATION OF THE THROTTLE LEVER FOR MAX. CONTINUOUS POWER

Performance check in accordance with Operators Manual.

If nominal performance won't be reached or is in excess of, examination of the installation and engine will be necessary.

ATTENTION

Don't conduct any test flights before fault has been traced and found.

NOTE

Make an entry of the details and test results into the engine log book.

BRP-Rotax
INSTALLATION MANUAL

INTENTIONALLY LEFT
BLANK

BRP-Rotax
INSTALLATION MANUAL

Chapter: 24-00-00
ELECTRICAL POWER

TOPICS IN THIS CHAPTER

Guidelines for the circuit wiring	2
Approval of electric and electronic components (Equipment qualification according to rtca/Do-160)	3
Battery	3
Internal generator	5
Rectifier regulator	6
Requirements for flawless operation of the rectifier regulator	7
Electronic modules	9
Ignition switches (MAG switch)	10
Assembly of the flat pin terminal	11
External alternator (optional extra)	13
Requirements for correct operation of the integrated rectifier regulator	14
Optional electric rev counter (tachometer)	16
Capacitor (electrical fuel pump, option)	18
Installation overview	19

BRP-Rotax INSTALLATION MANUAL

GUIDELINES FOR THE CIRCUIT WIRING

General

BRP-Rotax cannot prescribe the exact wiring installation design due to the existence of many different types of aircraft where our engines are installed. Accordingly, it is the responsibility of the airframe manufacturer to define the specific routing of the external wiring .

NOTE

Good practices for the installation of aircraft related wiring is given within following standards and Advisory Circulars (search on the internet):

- *Aviation Maintenance Technician Handbook FAA-H-8083-30*
- *AC 21-99: Aircraft Wiring and Bonding*
- *AC 43.13: Acceptable Methods, Techniques and Practices - Aircraft Inspection and Repair*

⚠ WARNING

Non-compliance can result in serious injuries or death!

The furnishing of proof in accordance to the latest FAR and EASA, has to be conducted by the aircraft manufacturer.

ATTENTION

The routing and connections have to be completed by the aircraft manufacturer in accordance to ASTM F2639 and effective certification FAR or EASA.

ATTENTION

The power supply to the various consumers (e.g. battery) must have adequate circuit protection (fuses, fusible links or circuit breakers). Using incorrectly rated fuses may result in destruction of the equipment. Do not route consumer cables (e.g. battery) alongside the secondary ignition cable. There is a risk of electromagnetic interference or damage.

ATTENTION

Do not bend, kink, pinch or otherwise improperly stress the wiring harness. Use proper routing, clamping and strain relief on wiring harnesses.

NOTE

Follow the relevant regulations (licensing conditions)

of the maintenance staff, during manufacturing of the wiring harness and repairs or modifications of the aircraft

BRP-Rotax INSTALLATION MANUAL

The representation of components (such as switches, protection devices etc.) that are not included in the scope of engine delivery is purely symbolic. It does not constitute a specification of the version and shall therefore only be seen functionally.

The actual interpretation/selection of the corresponding regulations and specified characteristics is the task of the aircraft manufacturer.

APPROVAL OF ELECTRIC AND ELECTRONIC COMPONENTS (EQUIPMENT QUALIFICATION ACCORDING TO RTCA/DO-160)

BATTERY

ATTENTION

The use of rechargeable batteries with lithium-ion technology should only be used in combination with a suitable battery management system. If such a battery is used, the responsibility is up to the aircraft manufacturer. The approval of the relevant aeronautical authority may be necessary. For installation of lithium-ion batteries refer e.g. to FAA AC No: 20-184

The aircraft manufacturer must ensure that the permissible limits of the battery (e.g. maximum permissible charging voltage) are not exceeded under any circumstances. Compliance with the operating limits of the battery must also be guaranteed in the event of a fault in the charging system. This can be ensured, for example, by using a suitable battery management system.

The specification of the battery must ensure that during each operating state and also during the transition between two operation states a sufficient supply of the avionics is guaranteed (e.g. during engine start). Depending on the applicable regulations avionics need to be supplied for at least 30 minutes with energy after a failure of the primary power supply in case they are required for safe operation of the aircraft.

If the aircraft is regularly started at temperatures below - 5 °C (23 °F) (ambient- and oil/coolant temperature are below this temperature) it is recommended to provide a connection for an external power supply and a possibility for adequate engine pre-heating.

ATTENTION

If all consumers are active, take care not to discharge the battery deeply.

Following battery specifications are recommended:

Interface Parameter	Min.	Max.	Nominal
Nominal Input Voltage			12 V
Internal resistance		Maximum 10 mΩ at -18 °C (-0.4 °F)	

BRP-Rotax INSTALLATION MANUAL

Interface Parameter	Min.	Max.	Nominal
Cold Cranking Ampere	350 A at -18 °C (-0.4 °F) (SAE J537)		
Capacity	16 Ah		

The usage of a battery with lower capacity may have a negative impact on the starting behavior of the engine. Additional electrical loads, which are in some cases required by law, may affect the battery performance during the starting process, (e.g. ACL (Anti Collision Light), Navigation Light, Avionics).

BRP-Rotax
INSTALLATION MANUAL

INTERNAL GENERATOR

NOTE

Approx. 250 W AC output at 5800 rpm. For DC output in connection with rectifier-regulator.

See [Chapter 24-00-00 section Rectifier regulator](#)

Feeding wires

NOTE

If the internal generator is not connected, then the yellow wires must be insulated so that a ground fault is not possible. The internal generator must not be operated in a short-circuit.

Feeding wires from the generator to rectifier-regulator on left side of ignition housing.

- 2 flexible cables, 1.5 mm² yellow (in shielding metal braid)
- length approx. 660 mm (26 in.) starting from ignition housing
- with on each plug socket 6.3 x 0.8 to DIN 46247

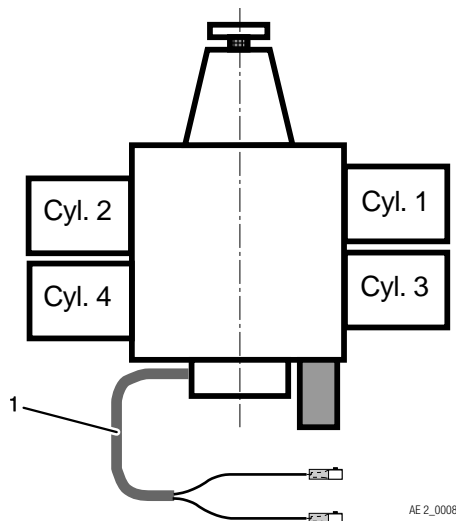

Figure 3.1: Feeding wires internal generator

1 Feeding wires (yellow)

BRP-Rotax INSTALLATION MANUAL

RECTIFIER REGULATOR

Type	Electronic full-wave rectifier regulator
Output voltage	14.2 V \pm 0.3 (from 1000 \pm 250 rpm)
Current limit	max. 22 A
Permissible component temperature	max. 80 °C (176 °F)

NOTE

The performance specifications are given for optimal cooled components. If necessary, use an additional supplementary heat sink for the rectifier regulator.

Weight See [Chapter 72-00-00 section Weight](#)

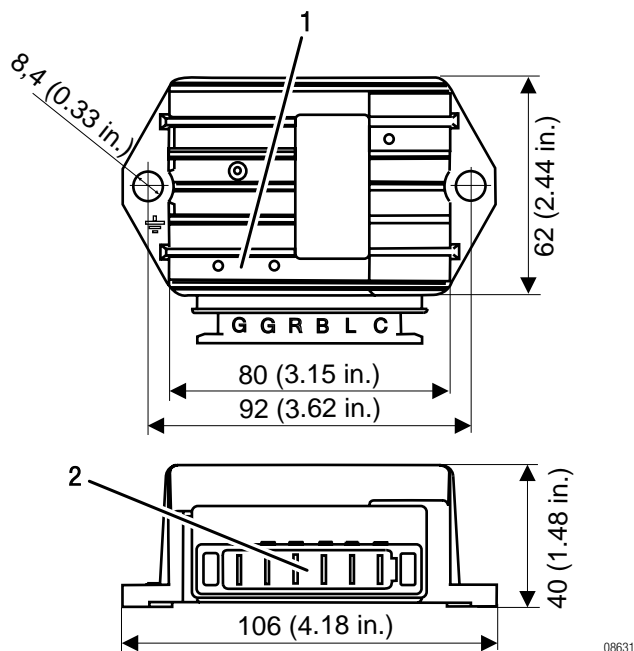

Figure 3.2: Rectifier regulator area component temperature and description of connections

1 Area component temperature

2 Description of connections:

G = yellow – from generator

R = red – to battery positive terminal

B = Battery positive terminal

L = Warning lamp circuit

C = Control or field circuit

BRP-Rotax
INSTALLATION MANUAL

REQUIREMENTS FOR FLAWLESS OPERATION OF THE RECTIFIER REGULATOR

ATTENTION

The voltage difference between battery and terminal C of regulator should be less than 0.2 V. Use cables in this area as short as possible and with adequate cross section.

ATTENTION

Never sever connection between terminal C and B of regulator (e.g. by removal of a fuse) while the engine is running. Overvoltage and regulator damage can occur! During engine stop break circuit between battery and terminal C to avoid discharge of battery!

NOTE

A charge-indicating lamp 3 W/12 V may be fitted on the instrument panel.
See Wiring diagram

- Body of regulator** Body of regulator must be grounded with no resistance allowed.
- Fuse** The rectifier regulator has to be protected by a slow blowing 25 A fuse or circuit breaker.
- Wire size** Wire size of the main circuit of at least 2.5 mm² (14 AWG).
- Capacitor** A capacitor of at least 22000 µF/25 V is necessary to protect the correct function of regulator and to flatten voltage. The regulator is not designed to store any electrical charge. If for any reason the battery or bus system is disconnected from the regulator while the engine is running (i.e. the master switch is shut off) the capacitor will safely absorb and dissipate the electrical charge produced by the generator. Otherwise the regulator would be damaged.
- Amperage**

ATTENTION

The current over engine speed graph was determined and is only effective under the following conditions.

- Ambient temperature: 20 °C (68 °F)
- Voltage: permanent 13.5 V/DC
- Tolerance: max. ± 5 %

BRP-Rotax
INSTALLATION MANUAL

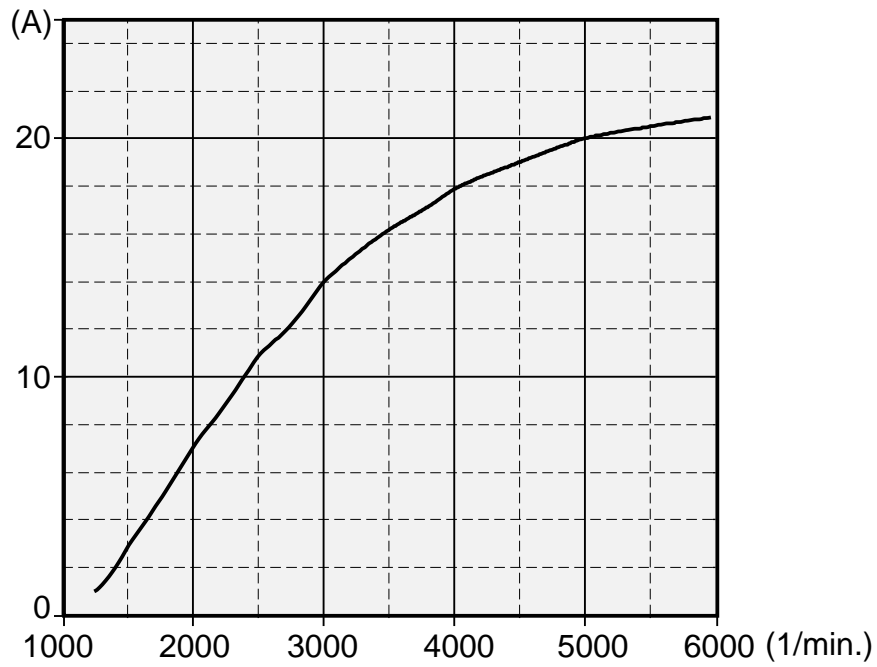

Figure 3.3: Current over engine speed graph

BRP-Rotax INSTALLATION MANUAL

ELECTRONIC MODULES

Component temperature

max. 80 °C (176 °F)

Easy start function (optional)

In order to use the easy start function the relevant connections to the starter relays and ignition switch need to be made.

The start function can be used for aircraft, which have an engine start problem in cold conditions.

NOTE

In addition also a modified fly wheel hub is offered, which aids improved starting.

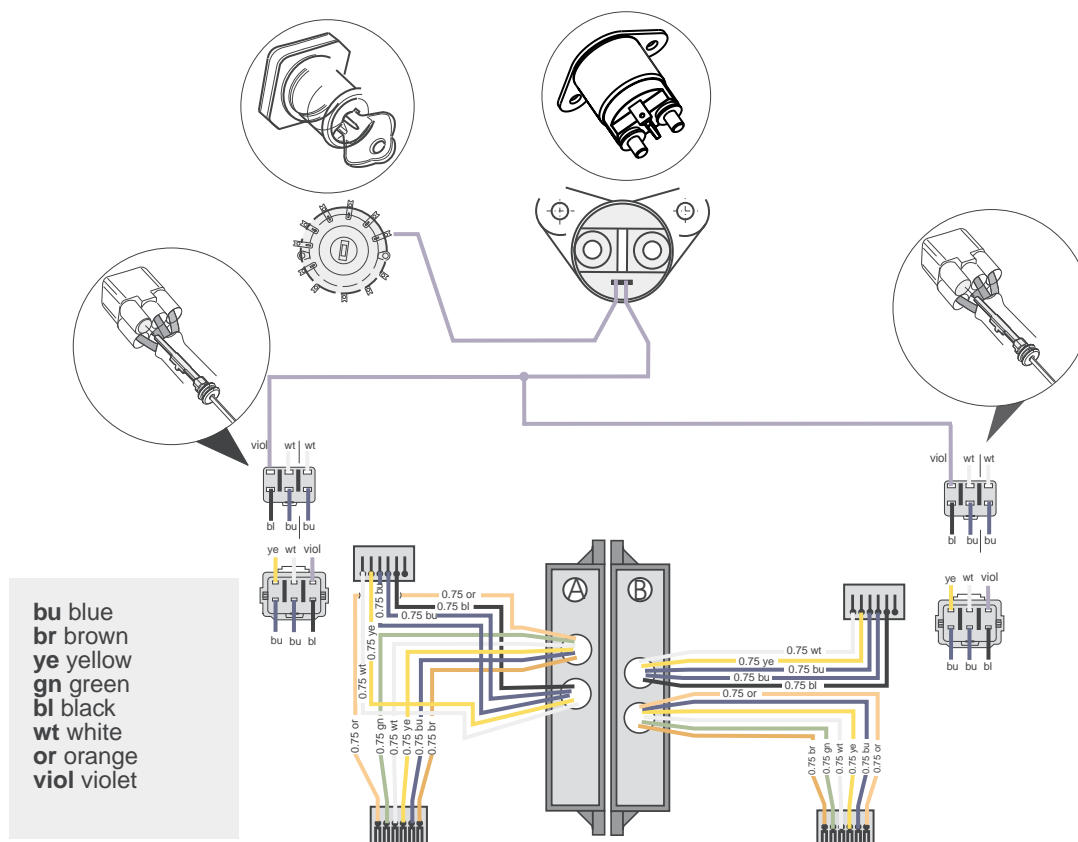

Figure 3.4: Easy start function electronic module

BRP-Rotax INSTALLATION MANUAL

IGNITION SWITCHES (MAG SWITCH)

- Type** Two separate, suitable on-off switches
- Switching voltage** min. 250 V
- Switching current** min. 0.5 A
- Wires** Wires from the ignition switches connect to the electronic module.

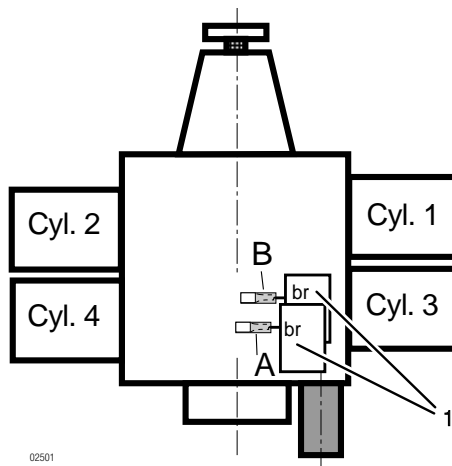

Figure 3.5: Electronic module

1 *Electronic module*

Wire

⚠ WARNING

Engine may start unless the MAG switch wire is grounded.

ATTENTION

Observe the minimum indications to the configuration!

Unshielded or insufficiently-shielded cables can cause engine shut-off due to electromagnetic and radio interference. The metal base of each ignition switch must be grounded to aircraft frame to prevent EMI.

The electromagnetic compatibility (EMC) and electromagnetic interference (EMI) depends essentially on the wire used.

Shielded flexible cable,

Shielding braid on both ends grounded to prevent EMI (e.g. specification MIL-27500/18).

Min. section area: 2x 0.75 mm² (18 AWG)

BRP-Rotax INSTALLATION MANUAL

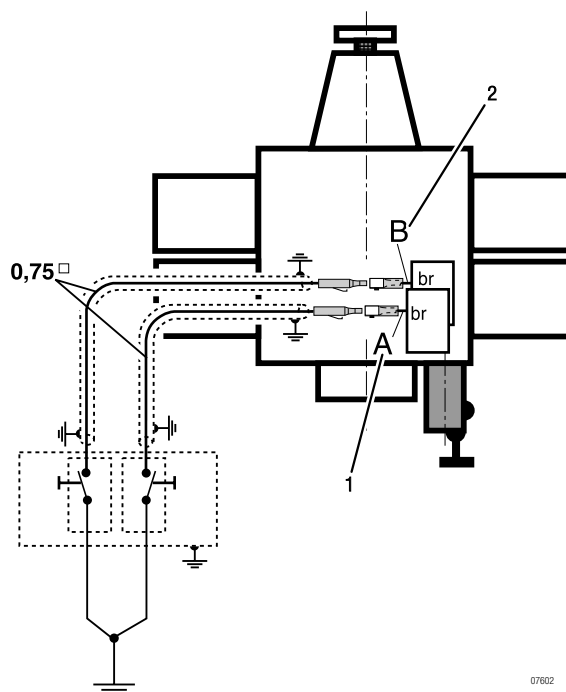

Figure 3.6: Wire

1 Wire for ignition circuit A

2 Wire for ignition circuit B

- Wire A** Wire of top electronic module (marked "A") for ignition circuit A.
- Wire B** Wire of bottom electronic module (marked "B") for ignition circuit B.
- Ignition circuit A** Ignition circuit A controls top spark plugs of cylinder 1 and 2; bottom spark plugs of cylinder 3 and 4.
- Ignition circuit B** Ignition circuit B controls top spark plugs of cylinder 3 and 4; bottom spark plugs of cylinder 1 and 2.
- Flexible wire** One each flexible wire 0.75 mm² (18 AWG) brown
Length approx. 35 mm (1 3/8") beginning at electronic module with one each plug socket and insulating sleeve 3.96 mm. At the new version the cable grommet and fasten connector are integrated in the 6-pole connector housing.
See SI-912-013 latest issue

ASSEMBLY OF THE FLAT PIN TERMINAL

NOTE

One each cable grommet and flat pin terminal are supplied loosely packed.

BRP-Rotax INSTALLATION MANUAL

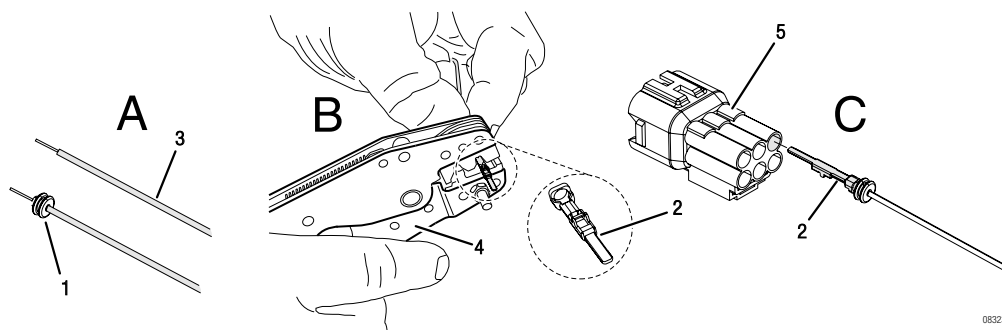

Figure 3.7: Assembly of the flat pin terminal

- | | |
|-------------------------------------|---------------------|
| 1 Cable grommet | 2 Flat pin terminal |
| 3 Wiring (airframe) | 4 Crimping pliers |
| 5 Position in the connector housing | |

Special tools

The following special tools and equipment are necessary for fitting the Faston connector.

Part no.	Description
n.a.	MOLEX Crimping pliers 64016-0035
n.a.	MOLEX Disassembly tool 63813-1500

Procedure

Step	Procedure
1	Strip cable as required.
2	Install the cable grommet in correct position and direction (A).
3	Use suitable crimping pliers to fit the fasten connector (B).
4	The cable grommet is held by the secondary crimp.
5	Push the Faston connector in the corresponding slot of the connector receptacle until it is locked in place (C).
6	Check for tight fit.
7	Press the pin holder (white) downwards using the long nose pliers.

NOTE

Faston connector and insulation sheath of the old version are available as spare part.

See SI-912-013 latest issue

NOTE

The pin holder must not be pressed with excessive force.

BRP-Rotax
INSTALLATION MANUAL

EXTERNAL ALTERNATOR (OPTIONAL EXTRA)

NOTE

The voltage regulator is integrated in the alternator.

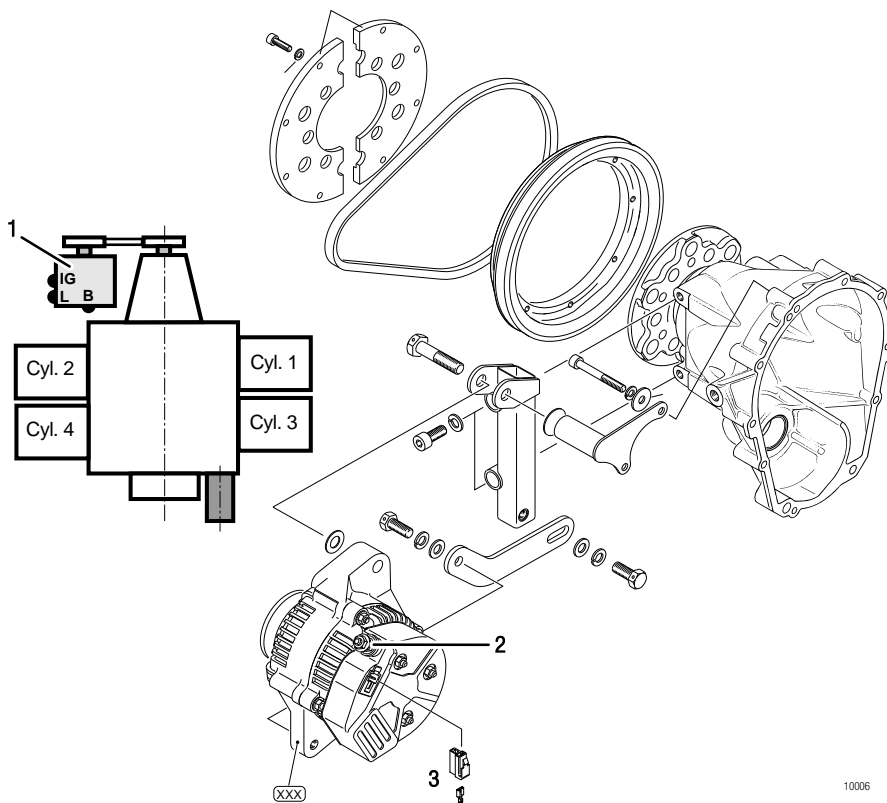

Figure 3.8: External alternator

- 1 External alternator
- 2 Positive terminal
- 3 Control wiring

Technical Data

Output	max. 600 W/DC at 6000 rpm
Output voltage	14.2 V - 14.8 V
Ambient temperature	Min. -30 °C (-22 °F) / Max. +90 °C (194 °F)
Weight	See Chapter 72-00-00 section Weight

BRP-Rotax INSTALLATION MANUAL

Connections

Power supply wires	Power supply wires for external alternator located on the outside of propeller gearbox.
Positive terminal	M6 screw connection (tightening torque 4 Nm / 35 in. lb) suitable for cable terminal according to DIN 46225
Grounding	Via engine block
Control wiring (field circuit)	Via supplied standard plug (Sumitomo 6111-2568) and 6.3 x 0.8 Faston connectors (female).

REQUIREMENTS FOR CORRECT OPERATION OF THE INTEGRATED RECTIFIER REGULATOR

Fuse	The rectifier regulator must be protected by a slow blowing fuse or circuit breaker. Fuse or circuit breaker rating must be determined by load, wire size and length.
Cross section	Wire size of the main circuit at least 4 mm ² (10 AWG).
Capacitor	A capacitor of at least 22000 µF/25 V is necessary to flatten voltage.
Amperage	

ATTENTION

The current over engine speed graph was determined and is only effective under the following conditions.

Ambient temperature:	20 °C (68 °F)
Voltage:	permanent 13.5 V
Tolerance:	max ± 5 %

NOTE

The speed of the external alternator is 1.24 times the crankshaft speed or 3 times the propeller speed.

BRP-Rotax INSTALLATION MANUAL

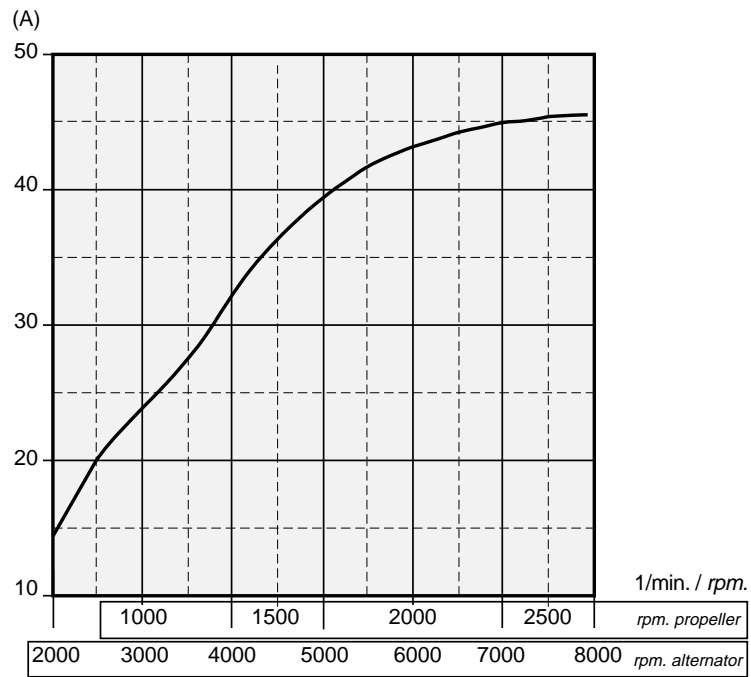

Figure 3.9: Current over engine speed graph

BRP-Rotax
INSTALLATION MANUAL

OPTIONAL ELECTRIC REV COUNTER (TACHOMETER)

General

See SI-13-1996 latest issue. See also the following graphs.

⚠ WARNING
Non-compliance can result in serious injuries or death! The furnishing of proof in accordance to the latest FAR and EASA, has to be conducted by the aircraft manufacturer.

Feeding wiring

Feeding wiring to electric rev counter on left side of ignition housing.
Length approx. 600 mm (24 in.) starting from ignition housing.

Connections

2 flexible cables 0.5 mm², white/yellow and blue/yellow in insulation wrap.

Measuring setup

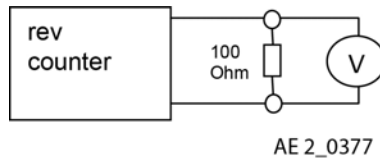

Figure 3.10

BRP-Rotax INSTALLATION MANUAL

Graphs

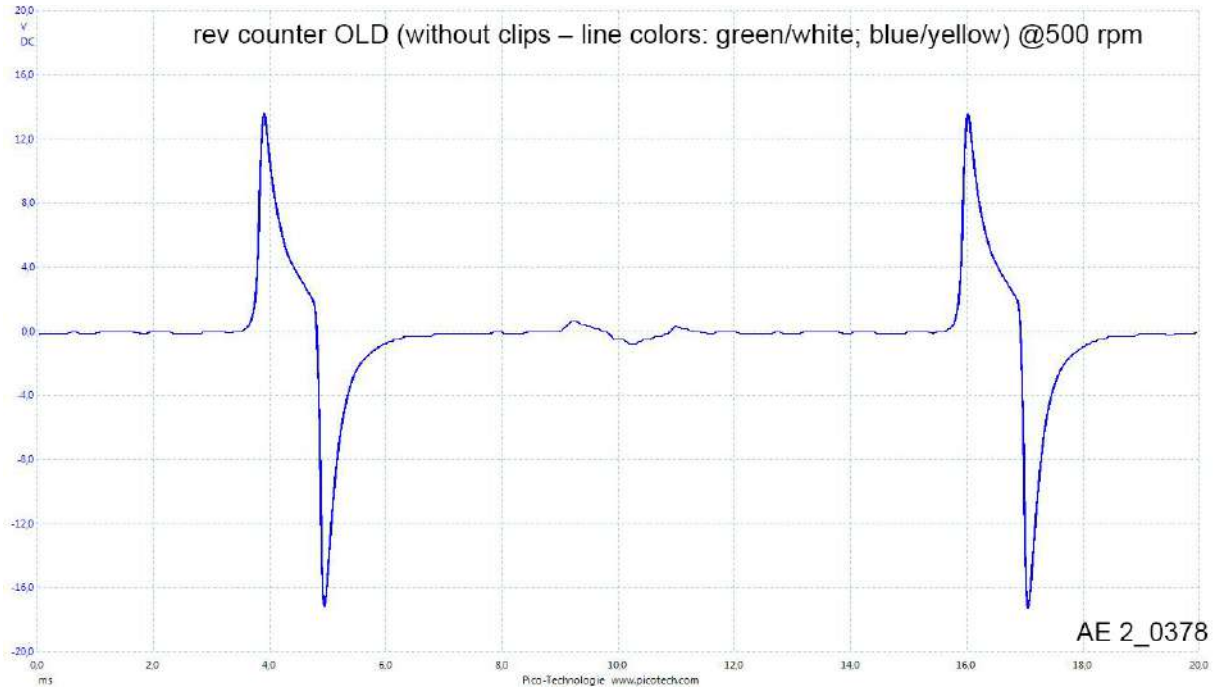

Figure 3.11: OLD

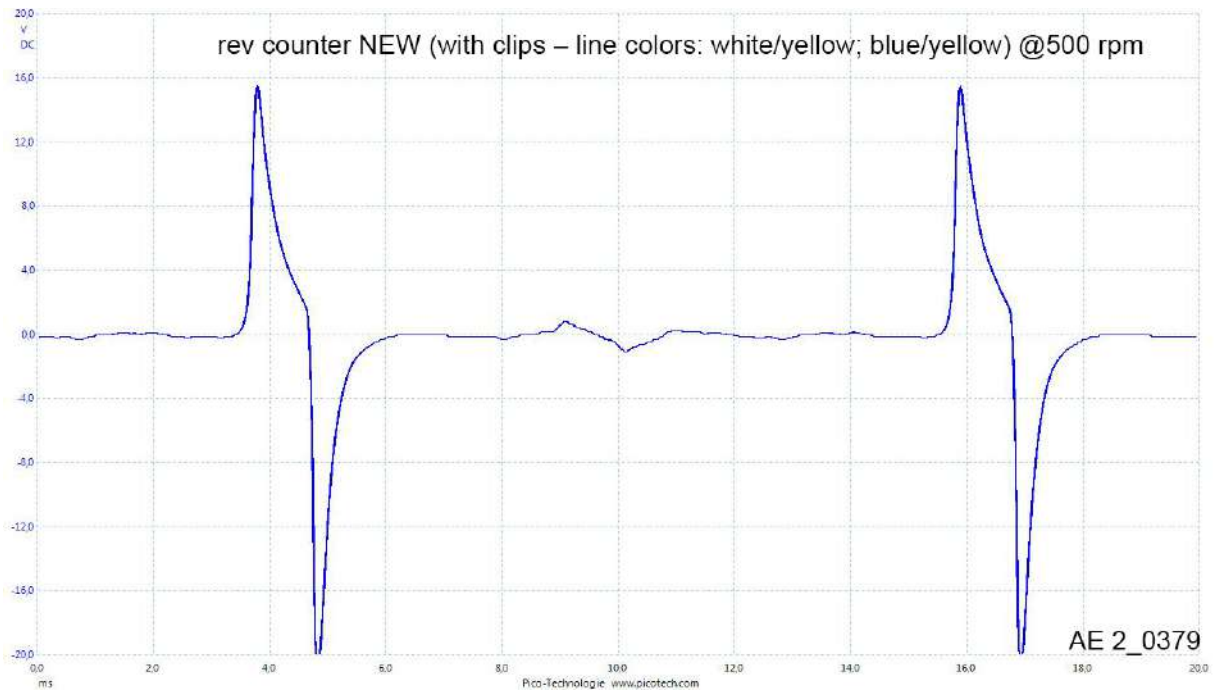

Figure 3.12: NEW

BRP-Rotax
INSTALLATION MANUAL

CAPACITOR (ELECTRICAL FUEL PUMP, OPTION)

ATTENTION

To warrant reliable operation of the electrical fuel pump the use of capacitor of at least 1 $\mu\text{F}/25\text{ V}$ is necessary.

See [Wiring diagram](#)

BRP-Rotax INSTALLATION MANUAL

INSTALLATION OVERVIEW

Scope of delivery Items/components which are not included in the standard engine scope of delivery must be certified.

⚠ WARNING

Non-compliance can result in serious injuries or death!
The furnishing of proof in accordance to the latest FAR and EASA, has to be conducted by the aircraft manufacturer.

See [Wiring diagram](#)

Position	Supply
1-9	Are included in the standard volume of supply of the engine.
22-24	Are included in the standard volume of supply of the engine.
10-14	Are available as accessory.
15-22, 25	Can't be supplied by BRP-Rotax.

Components The engine is supplied with the wiring and ready to operate. Only the following connections to the aircraft have to be established:

- integrated generator
- external rectifier regulator
- electronic modules
- electric starter
- start relay
- items conditional for operation like circuit breakers, ON-OFF switches, control lamps, relays, instrumentation and capacitors.

Optional extras

- external alternator
(as option if the output of the integrated generator is inadequate)
- electric rev counter (accessory)
- consumer (battery)

BRP-Rotax INSTALLATION MANUAL

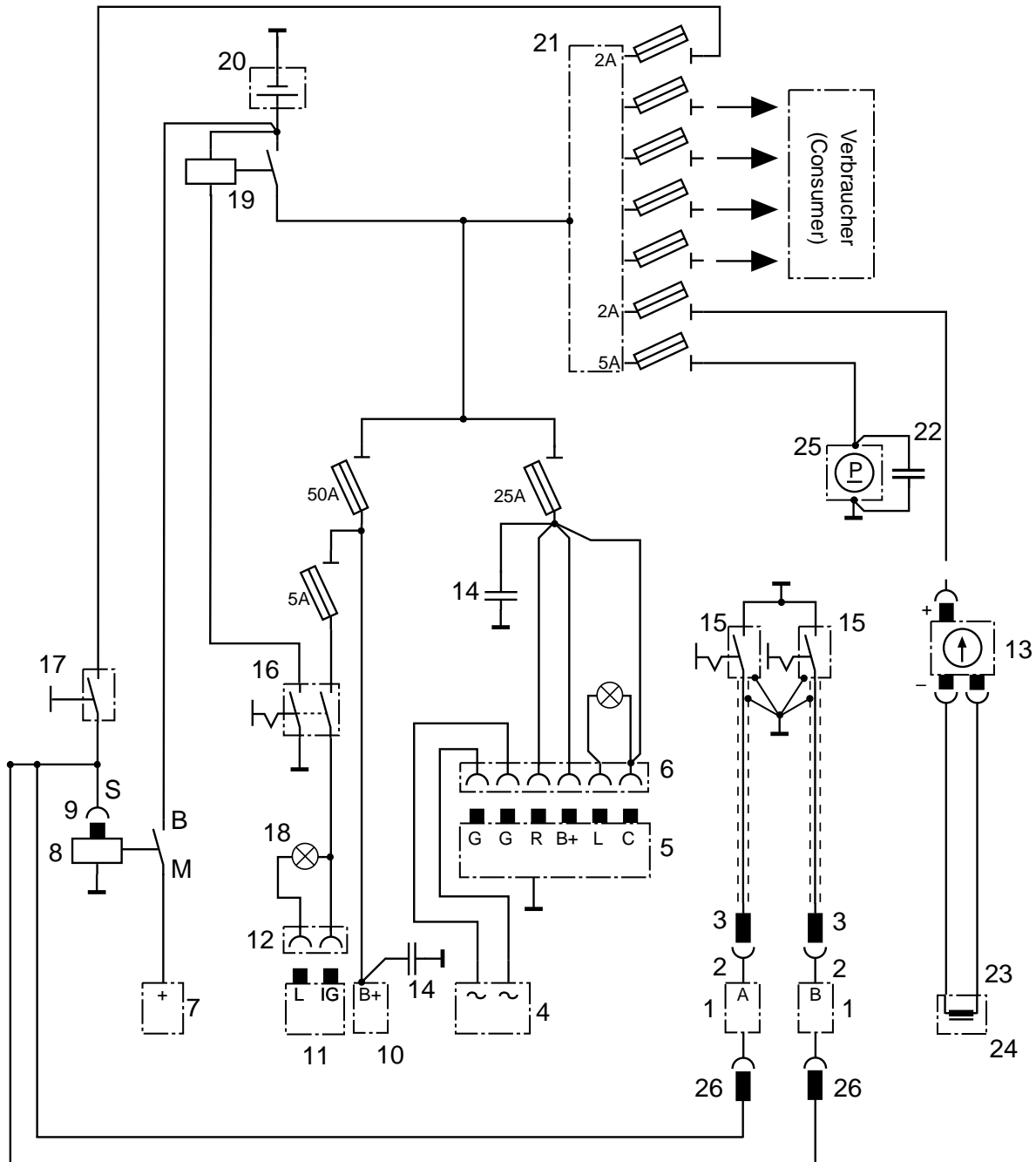

Figure 3.13: Wiring diagram

BRP-Rotax INSTALLATION MANUAL

- | | | | |
|-----|---|------|--|
| 1 | 2 Electronic modules (A and B) | 2, 3 | Plug connection for ignition switch |
| 4 | Integrated generator | 5, 6 | External regulator rectifier with plug connections |
| 7 | Electric starter | 8, 9 | Start relay with plug connection |
| 10, | | | |
| 11, | External alternator with connection | 13 | Electric rev counter |
| 12 | | | |
| 14 | Capacitor 22000 μ F | 15 | 2 Ignition switches |
| 16 | Master switch | 17 | Starter switch |
| 18 | Control lamp | 19 | Battery relay |
| 20 | Battery | 21 | Bus bar |
| 22 | Capacitor 1 μ F | 23 | Plug connection for trigger coil assy. |
| 24 | Trigger coil assy. (tachometer) | 25 | Electrical fuel pump |
| 26 | (ASM) Easy-start connection wires at the electronic modules | | |

BRP-Rotax
INSTALLATION MANUAL

INTENTIONALLY LEFT
BLANK

BRP-Rotax
INSTALLATION MANUAL

Chapter: 61-00-00
PROPELLER DRIVE

TOPICS IN THIS CHAPTER

Interface description	2
Propeller drive	2
System limitations	4
Vacuum pump	5
Hydraulic governor for constant speed propeller	7

BRP-Rotax INSTALLATION MANUAL

INTERFACE DESCRIPTION

Interface Overview

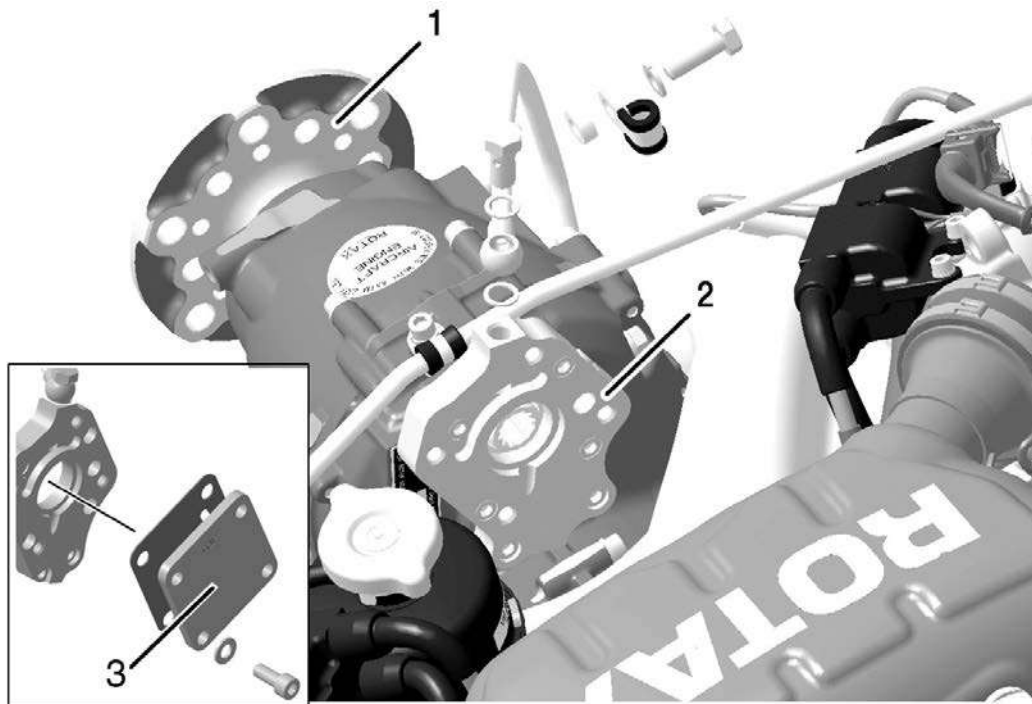

AE_914_0198

Figure 4.1: TYPICAL Interface

- 1 Propeller shaft (mechanical. Interface)
- 2 Governor flange (hydraulic. Interface)
- 3 Cover plate

NOTE

The cover plate and its screw used for delivery needs to be removed before engine operation. The cover may not be used in operational condition.

PROPELLER DRIVE

General

The propeller in tractor or pusher arrangement must be fitted on the propeller flange in accordance with applicable regulations. As required utilize one of three possible pitch circle diameters (P.C.D.) on the flange.

Certification of the propeller sizing and arrangement to the latest requirement such as FAR or EASA has to be conducted by the aircraft manufacturer.

⚠ WARNING

Never operate the engine without propeller as this results in serious engine damage from overspeeding. Never fit the propeller directly on the crankshaft.

BRP-Rotax INSTALLATION MANUAL

ATTENTION

Modification of the propeller shaft is not permitted.

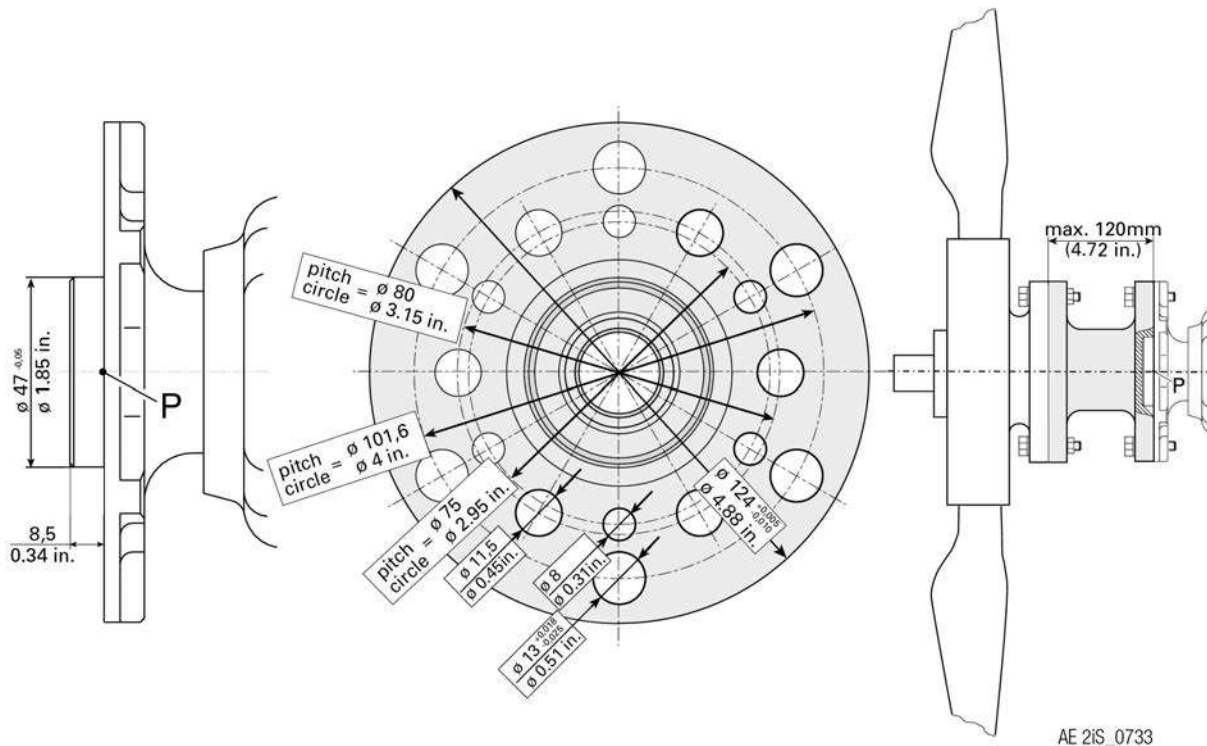

Figure 4.2: Propeller shaft flange

Attachment of propeller on prop. shaft flange

Pitch circle diameter 75 mm +/- 0.3 mm (2.95 in. +/- 0.012 in.)	6x through holes 8 mm (0.31 in.)
Pitch circle diameter 80 mm +/- 0.3 mm (3.15 in. +/- 0.012 in.)	6x through holes 11.5 mm (0.45 in.)
Pitch circle diameter 101.6 mm +/- 0.3 mm (4 in. +/- 0.012 in.)	6x through holes 13 mm (0.51 in.)
Hub diameter	47 mm (1.85 in.)

NOTE

Propeller hub has to be centered on dia. 47 mm (1.85 in.).

Direction of rotation

Direction of rotation of the propeller flange:

left, counter clockwise, looking towards face of flange

BRP-Rotax INSTALLATION MANUAL

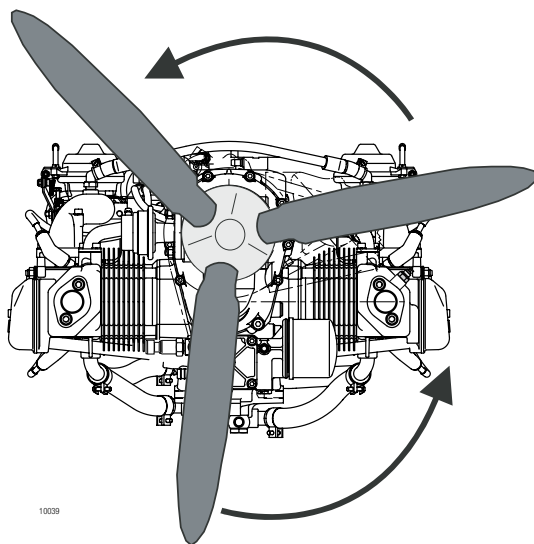

Figure 4.3: Direction of rotation

Transmission Gear transmission:
 $i=2.2727$ (50 Teeth/22 T) or $i= 2.4286$ (51 Teeth/21 T), depends on configuration

Vibration analysis Vibration analysis of the whole system (engine, suspension, propeller etc.) should be carried out as part of the certification process.
 If no limits are available in the technical literature, a max. of 0.5 IPS (inches per second) at 5000 rpm. can be assumed.

SYSTEM LIMITATIONS

Operating limits



Refer to latest issue of the Operators Manual .

Moment of inertia	System Limit	Range (normally)
	Moment of inertia on propeller	between 1500 kg cm ² (3.559 lb ft ²) and 6000 kg cm ² (14.238 lb ft ²)

Out of balance Dynamic balancing of the propeller as specified by the propeller manufacturer must be carried out.

Propeller shaft	System Limit	Min.	Max.
	Extension of the propeller shaft	–	maximal 120 mm (4.72 in.)

Torque output Max. torque:
 ROTAX® 912 A, F, UL at $i=2,2727$: 238 Nm (on propeller)
 ROTAX® 912 A, F, UL at $i=2,4286$: 255 Nm (on propeller)
 ROTAX® 912 S, ULS at $i=2,4286$: 315 Nm (on propeller)

BRP-Rotax
INSTALLATION MANUAL

VACUUM PUMP

⚠ WARNING

Non-compliance can result in serious injuries or death!
The furnishing of proof in accordance to the latest FAR and EASA, has to be conducted by the aircraft manufacturer.

Graphic

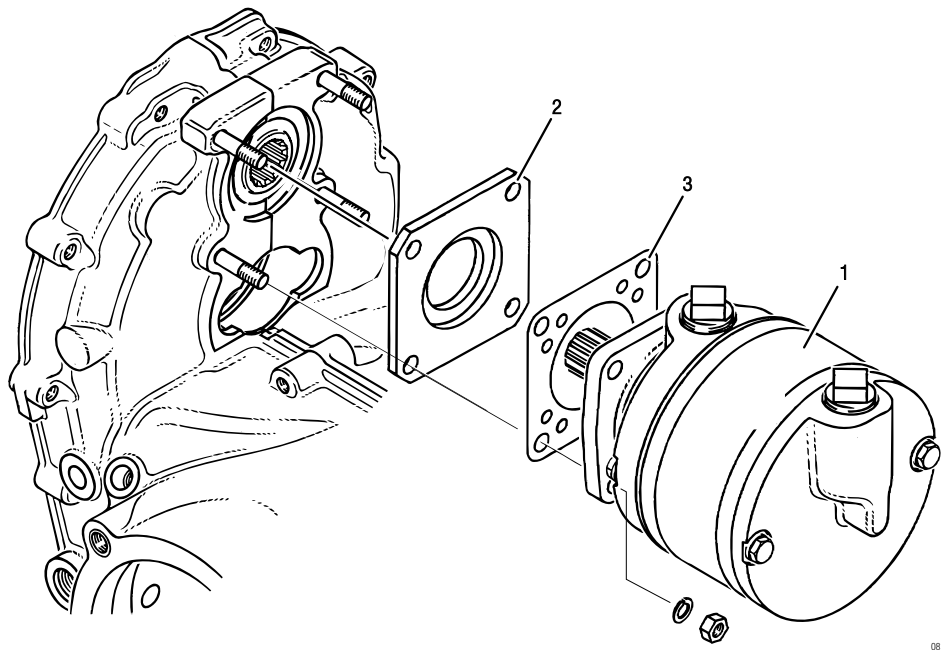

Figure 4.4: Vacuum pump

- 1 Vacuum pump
- 3 Gasket

- 2 Attachment flange

BRP-Rotax INSTALLATION MANUAL

Attachment flange

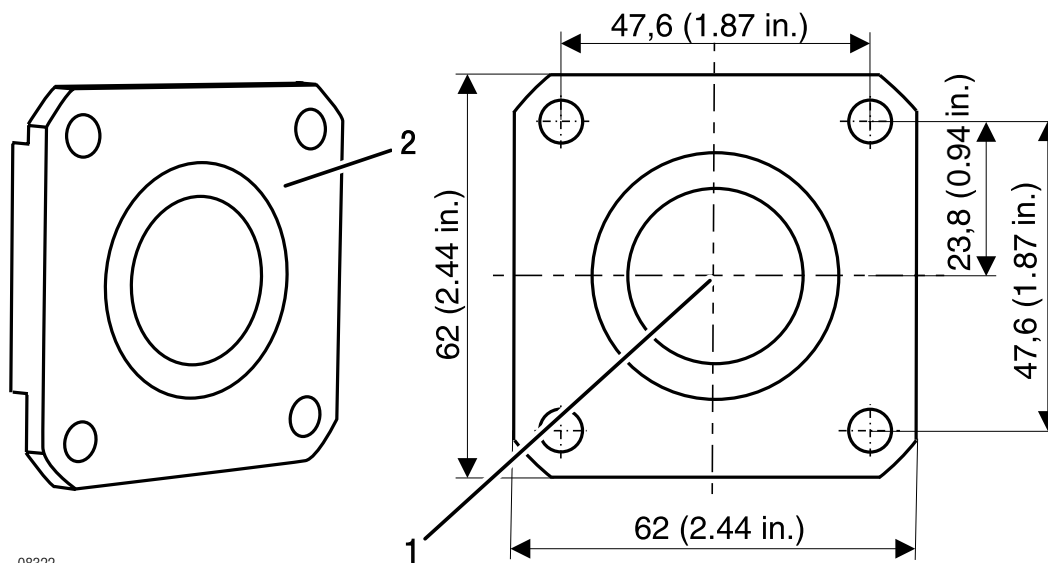

Figure 4.5: Attachment flange

1 Connection for vacuum pump

2 Attachment flange

	x-axismm [in]	y-axismm [in]	z-axismm [in]
Connection	-206.3 [8.12]	0	51.5 [2.03]

Speed reduction

Speed reduction from crankshaft to vacuum pump is 1.724 or 1.842, i.e. the vacuum pump runs with 0.58 or 0.54 of engine speed.

Connection

ATTENTION
Obey the manufacturers instructions!

Thread size	M6
Effective thread length	max. 17 mm (9/16")
Vacuum pump drive	Internal spline 20/40 SMS 1834 NA 14x1,27x30x12
Power consumption	max. 600 W

BRP-Rotax
INSTALLATION MANUAL

HYDRAULIC GOVERNOR FOR CONSTANT SPEED PROPELLER



See Service Bulletin SB-912-052, Installation/use of governors for ROTAX® Engine type 912, latest issue.

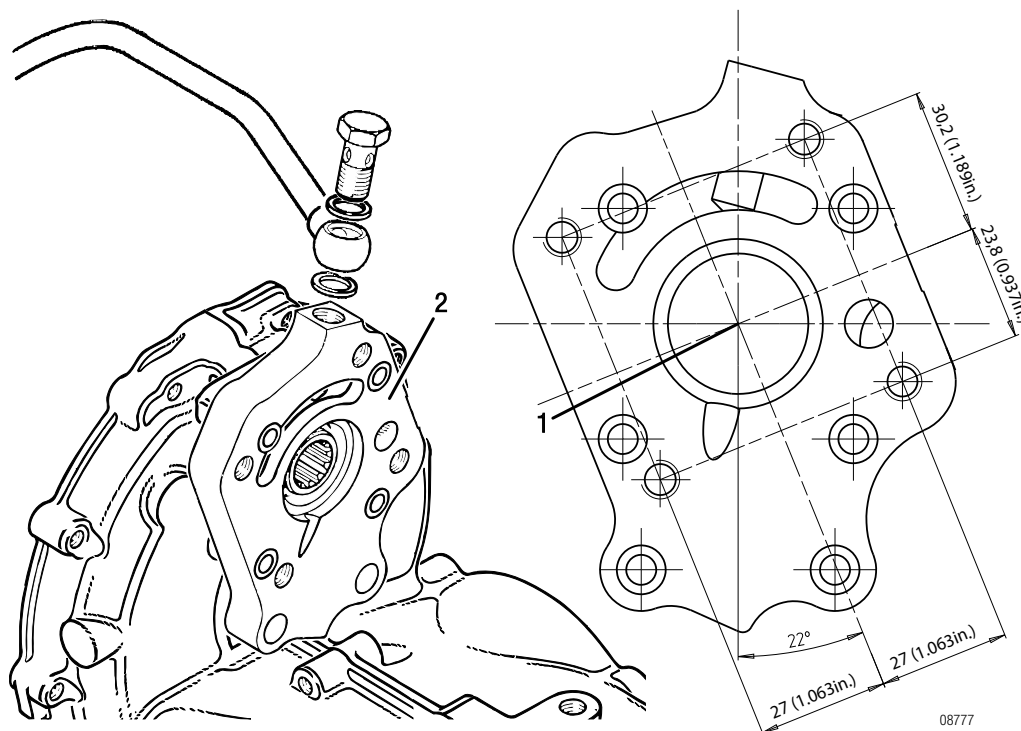

Figure 4.6: Crankcase flange

- 1 Connection for hydraulic governor 2 Governor flange

Drive

Drive via propeller gearbox.
 Position of the hydraulic governor connection (1) on the governor flange:

x-axis [mm/in]	y-axis [mm/in]	z-axis [mm/in]
-206.3 (8.12)	0	51.5 (2.03)

BRP-Rotax INSTALLATION MANUAL

Connection

ATTENTION
Obey the manufacturers instructions!

Technical Data

Gear ratio from crankshaft to hydraulic governor is 1.842, i.e. the hydraulic governor runs at 0.54 times engine speed.

Mounting pad	AND20010
Thread size	M8
Thread length	max. 14 mm (0.55 in)
Toothing	Internal spline 20/40 SMS 1834 NA 14x1,27x30x12
Power consumption	max. 600 W
Operating pressure	max. 30 bar (435 psi)

BRP-Rotax
INSTALLATION MANUAL

Chapter: 72-00-00
ENGINE

TOPICS IN THIS CHAPTER

Overview2

Interface overview3

Technical data8

 Weight.....8

 Installation dimensions – standard configuration9

 Center of gravity of engine and standard accessories.....9

 Moments of inertia10

Operating limits 11

System limitations 12

BRP-Rotax INSTALLATION MANUAL

OVERVIEW

⚠ WARNING

Non-compliance can result in serious injuries or death!
The furnishing of proof in accordance to the latest FAR and EASA, has to be conducted by the aircraft manufacturer.

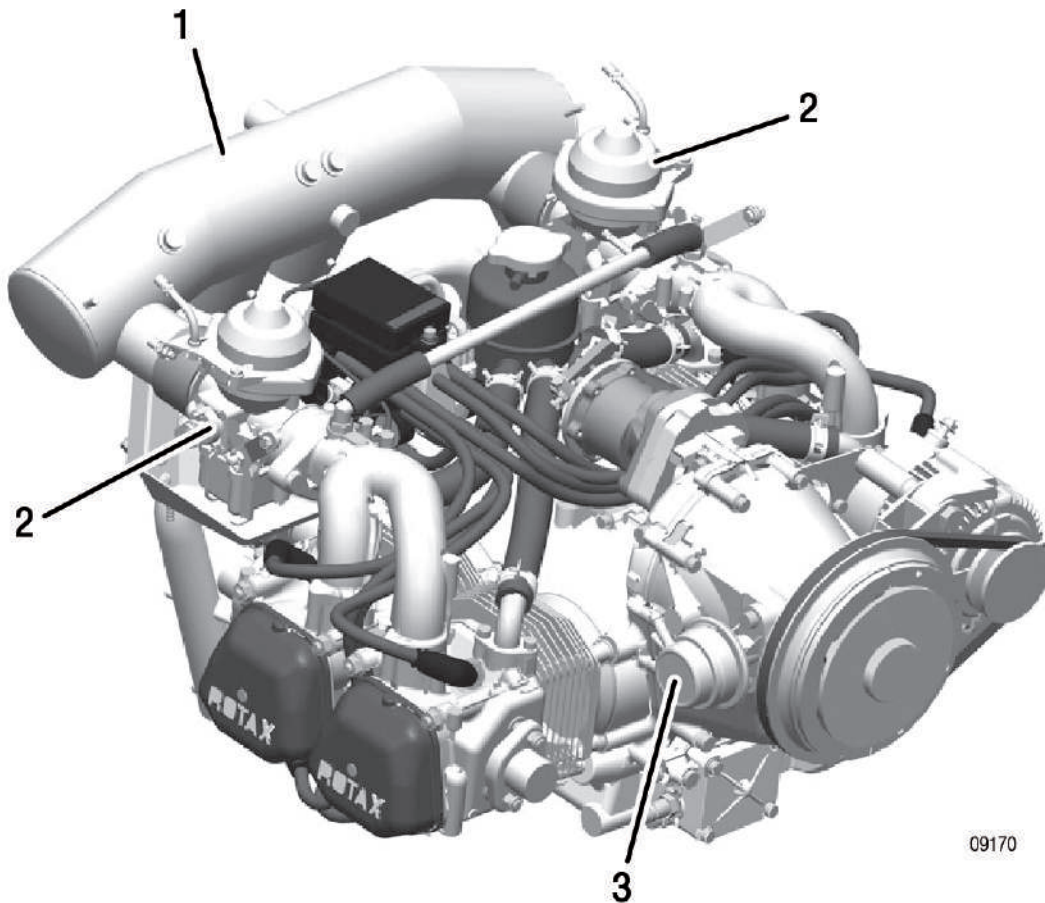

Figure 5.1: Engine

1 Airbox

2 Carburetor

3 Mechanical fuel pump

BRP-Rotax
INSTALLATION MANUAL

INTERFACE OVERVIEW

Regarding change of temperature sensor position, see following figures.

NOTE

It is NOT mandatory to retrofit engines with the old cylinder heads. The different versions of the cylinder heads can be mixed installed, but make sure, if and at which position the cylinder head temperature and coolant temperature is measured. This also defines the naming of the indicating instrument with the appropriate temperature limit.

Suffix -01:

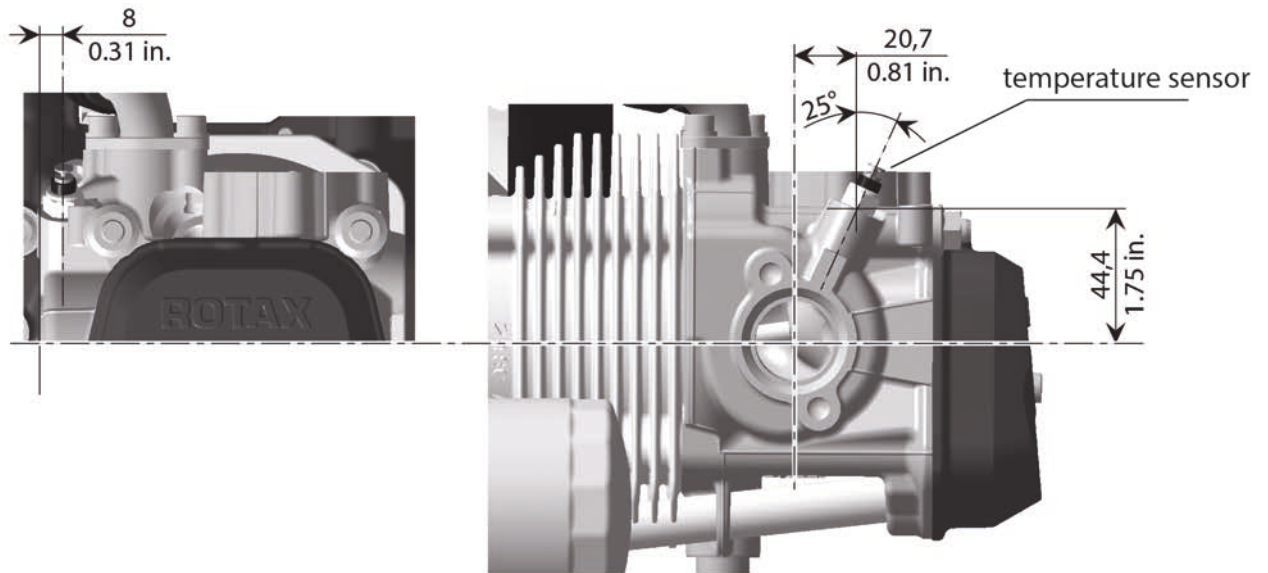

Figure 5.2: Position temperature sensor - new configuration

BRP-Rotax INSTALLATION MANUAL

without Suffix -01:

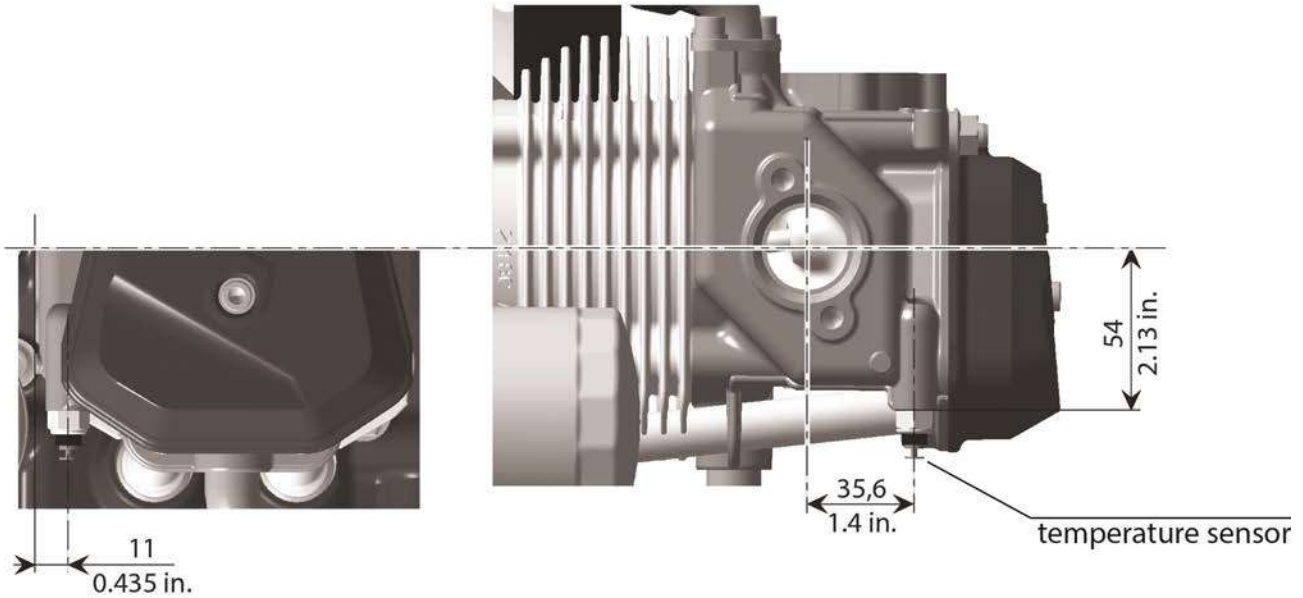

Figure 5.3: Position temperature sensor - old configuration

General

NOTE

Allow ± 1 mm on all stated dimensions as manufacturing tolerance.

A	points of attachment (for engine transport) - centre of gravity		
P	zero reference point for all dimensions		
x, y, z	axes for system of coordinates		
PTO	power take off side	MAG	magneto side
Cyl. 1	Cylinder 1	Cyl. 3	Cylinder 3
Cyl. 2	Cylinder 2	Cyl. 4	Cylinder 4

BRP-Rotax INSTALLATION MANUAL

Side view

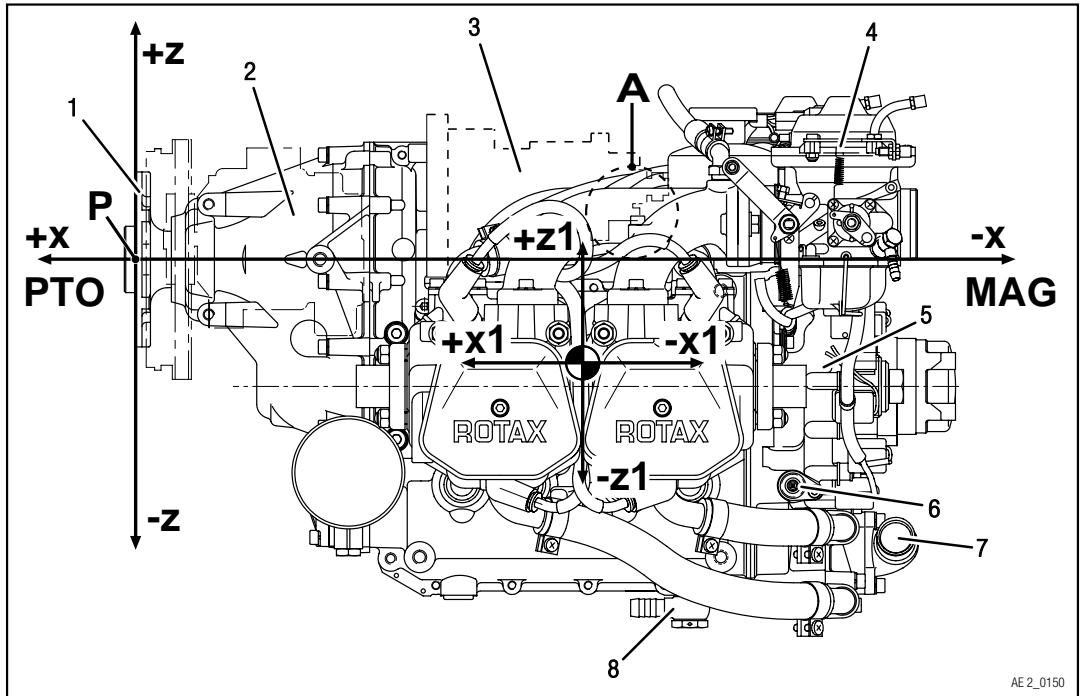

Figure 5.4: Side view engine

- | | |
|---|---|
| <ul style="list-style-type: none"> 1 Propeller flange 2 Propeller gearbox 3 Vacuum pump or hydraulic governor for constant speed propeller 4 Constant depression carb. 5 Ignition cover 6 Connection for mechanical rev counter 7 Coolant pump 8 Connection for oil return line | <ul style="list-style-type: none"> 2 Propeller gearbox 4 Constant depression carb. 6 Connection for mechanical rev counter 8 Connection for oil return line |
|---|---|

BRP-Rotax INSTALLATION MANUAL

Front view

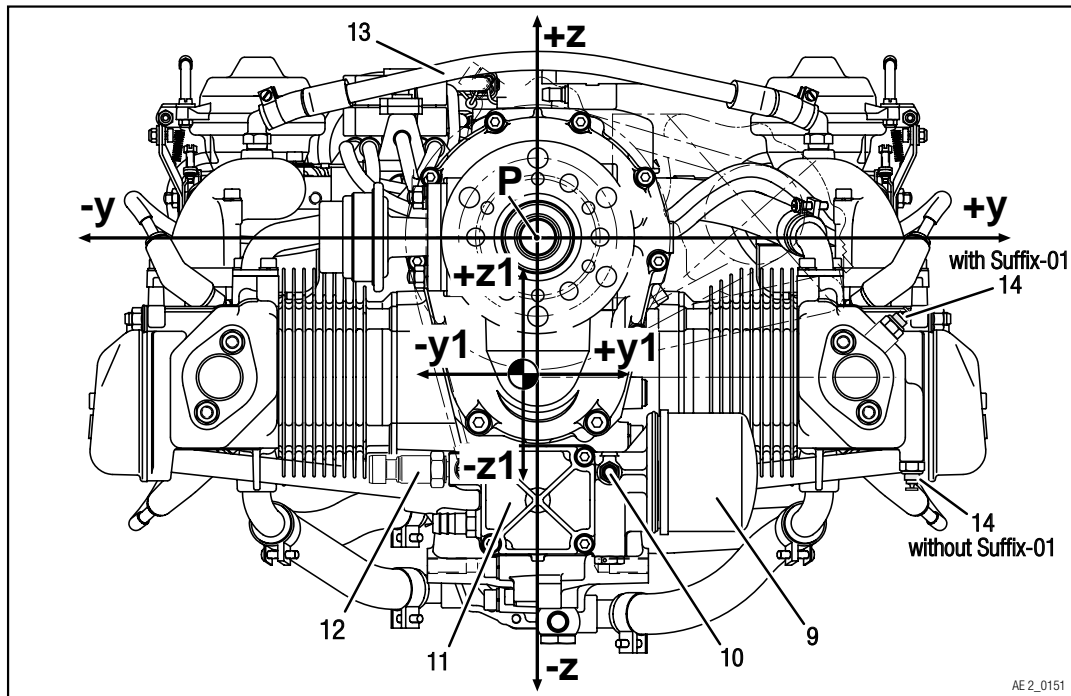

Figure 5.5: Front view engine

- | | |
|--|---|
| <p>9 Oil filter</p> <p>11 Oil pump</p> <p>13 Compensation tube</p> | <p>10 Oil temperature sensor</p> <p>12 Oil pressure sensor</p> <p>Cylinder head temperature sensor OR
coolant temperature sensor (depends on
Suffix-01)</p> <p>14</p> |
|--|---|

BRP-Rotax INSTALLATION MANUAL

Top view

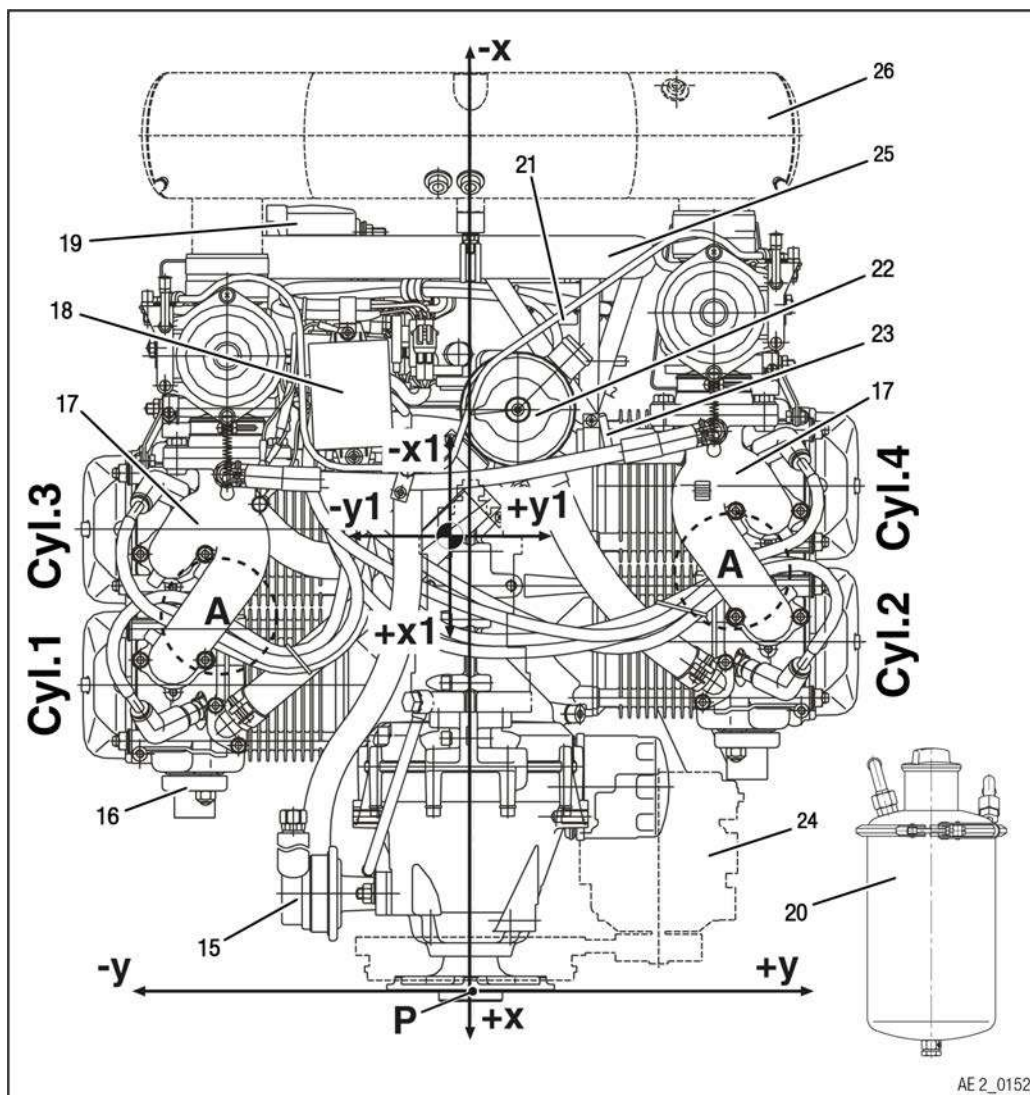

Figure 5.6: Top view engine

- | | |
|-------------------------------------|------------------------|
| 15 Mechanical fuel pump | 16 Exhaust socket |
| 17 Intake manifold | 18 Electronic module |
| 19 Electric starter | 20 Oil tank |
| 21 Ignition housing | 22 Expansion tank |
| 23 Connection for manifold pressure | 24 External alternator |
| 25 Engine suspension frame assy. | 26 Airbox assy. |

BRP-Rotax INSTALLATION MANUAL

TECHNICAL DATA

To maintain clarity, only data relevant for engine installation and operation will be stated in the Manual.

NOTE

Connecting sizes, capacities, gear and reduction ratios, electric power, permissible temperatures, etc. can be found in the respective section of engine installation or other relevant engine type documentation.

WEIGHT

The engine weight is defined by the following conditions:

- Engine dry from serial production with internal alternator, with overload clutch (see chapter Description of design).

Configuration

Config.	Weight	
	912 A, F, UL	912 S, ULS
2	57.1 kg (125 lb)	58.3 kg (128 lb)
3	59.8 kg (132 lb)	61.0 kg (134 lb)

Accessories

Accessories	Weight	Spare part	Optional ³
Airbox	1.3 kg (2.8 lb)	X	X
Exhaust system	approx. 4 kg (8.8 lb)	X	X
External alternator assy.	3.0 kg (6.6 lb)	X	
HD-starter ⁴	additional +0.43 kg (1 lb)	X	X
Hydraulic governor assy. incl. drive (depending on type)	approx. 2.2 kg to 2.7 kg (4.8 lb to 6 lb)		
Radiator	1.0 kg (2.2 lb)	X	
Cooling air baffle	0.36 kg (0.79 lb)	X	X
2x Air filter	0.3 kg (0.66 lb)	X	
Engine mount	2.0 kg (4.4 lb)	X	X

3. Can be installed original to the engine at the factory (also available as a spare part).

4. On 912 S/ULS included / standard, on 912 A/F/UL optional as spare part

BRP-Rotax INSTALLATION MANUAL

Accessories	Weight	Spare part	Optional ⁵
Oil radiator	0.55 kg (1.21 lb)	X	
Rectifier regulator	0.3 kg (0.66 lb)	X	
Starter relay	0.145 kg (0.32 lb)	X	
Overload clutch	1.7 kg (3.7 lb)	X	X ⁶
Vacuum pump assy.	0.8 kg (1.76 lb)	X	

INSTALLATION DIMENSIONS – STANDARD CONFIGURATION

NOTE

All distances are given in relation to the reference coordinate system (P).

	Pos. (+)	Neg. (-)	Total
Max. dimension along x-axis [mm]	8.5 (0.33 in.)	-581 (-22.87 in.)	589.5 (23.21 in.)
Max. dimension along y-axis [mm]	288 (11.34 in.)	-288 (-11.34 in.)	576 (22.68 in.)
Max. dimension along z-axis [mm]	118 (4.65 in.)	-276 (-10.87 in.)	394 (15.51 in.)

CENTER OF GRAVITY OF ENGINE AND STANDARD ACCESSORIES

NOTE

All distances are given in relation to the reference coordinate system (P).

	Standard configuration 3	External alternator	Hydraulic governor	Vacuum pump
Center of gravity on x-axis [mm]	-316 (12.44 in.)	-100 (3.94 in.)	-276 (10.87 in.)	-255 (-10.04 in.)
Center of gravity on y-axis [mm]	-5 (0.20 in.)	139 (5.47 in.)	0	0
Center of gravity on z-axis [mm]	-83 (3.27 in.)	6 (0.24 in.)	56 (2.20 in.)	56 (2.20 in.)

5. Can be installed original to the engine at the factory (also available as a spare part).
6. On 912 S/ULS included / standard, on 912 A/F/UL optional as spare part

BRP-Rotax
INSTALLATION MANUAL

MOMENTS OF INERTIA

	Configuration 2	Configuration 3
axis x1-x1 [kg cm ² (lb ft ²)]	11100 (26.341)	11600 (27.527)
axis y1-y1 [kg cm ² (lb ft ²)]	10900 (25.866)	11390 (27.029)
axis z1-z1 [kg cm ² (lb ft ²)]	17400 (41.291)	18200 (43.190)

BRP-Rotax
INSTALLATION MANUAL

OPERATING LIMITS

	Manual
Exhaust gas temperature	See OM 912 Series chapter 2.1 / 2.2
Deviation from the apparent perpendicular	See OM 912 Series chapter 2.1
Ambient temperature for electronic module	See chapter 24-00-00 section electronic module
Acceleration	See OM 912 Series chapter 2.1 / 2.2
Engine speed	See OM 912 Series chapter 2.1 / 2.2
External alternator	See OM 912 Series chapter 2.1 / 2.2
Fuel pressure	See OM 912 Series chapter 2.1 / 2.2
Cylinder head temperature	See OM 912 Series chapter 2.1 / 2.2
Coolant temperature	See OM 912 Series chapter 2.1 / 2.2
Oil pressure	See OM 912 Series chapter 2.1 / 2.2
Oil temperature	See OM 912 Series chapter 2.1 / 2.2
Ambient temperature for start up	See OM 912 Series chapter 2.1 / 2.2
Governor	See OM 912 Series chapter 2.1 / 2.2

BRP-Rotax INSTALLATION MANUAL

SYSTEM LIMITATIONS

Operating limits



Refer to latest issue of the Operators Manual .

General

The engine design is for a conventional, non-aerobatic, tractor or pusher configuration with the oil return port in the optimum position. Assuming these points are taken into consideration, the engine will be properly lubricated in all flight profiles.

Bank angle

The resulting bank angle β (depending on acceleration/deceleration) may never exceed the max. bank angle.

NOTE

Pitch or role angle α is not equal with β , except stabilized condition (without acceleration).

Installation position

The oil system, fuel system and the cooling system are unsuitable for upside-down / inverted installation of the engine.

System Limit	Min.	Max.
Static roll angle β		40°

The oil level should be in the upper half (between the “50%” and the “Max.” mark) and should never fall below the “Min.” mark. For the oil level measuring procedure refer to the latest version of the respective Operators Manual.

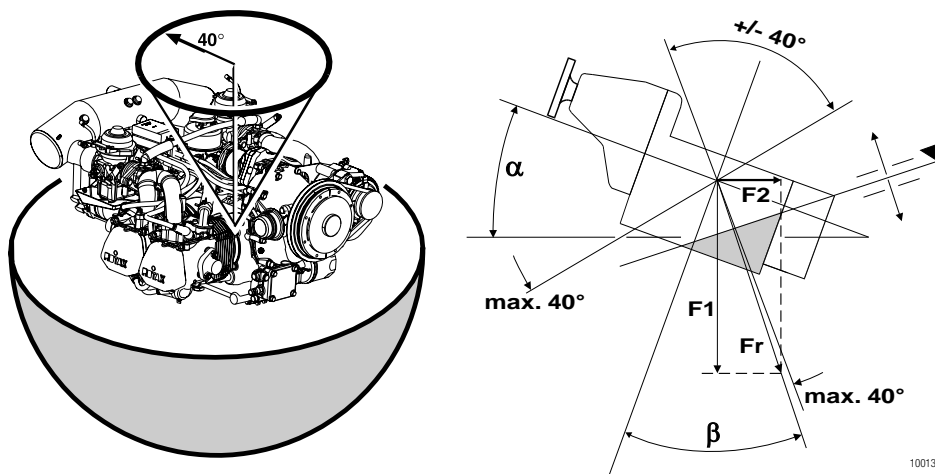

Figure 5.7: Bank angle

Angle/force	Description
α	Bank or rotation
F1	Gravity

BRP-Rotax
INSTALLATION MANUAL

Angle/force	Description
β	Bank angle
F2	Acceleration
Fr	Result of F1 and F2

BRP-Rotax
INSTALLATION MANUAL

INTENTIONALLY LEFT
BLANK

BRP-Rotax
INSTALLATION MANUAL

Chapter: 72-60-00
AIR INTAKE SYSTEM

TOPICS IN THIS CHAPTER

Air intake system.....2
 System limitations2

Requirements on the air intake system4
 Interface overview4
 Technical data6
 Intake air ducting6
 Air filter7
 Airbox8

Data for optional components of air intake system.....9

BRP-Rotax INSTALLATION MANUAL

AIR INTAKE SYSTEM

The air intake system is determined essentially by the demands of engine and of the acceptable noise emission on the intake side. An airbox can be supplied by BRP-Rotax as an option.

Performance data as specified and limits of operation can only be warranted by employment of the GENUINE ROTAX® Airbox.

Installation note If it will be necessary to use a different airbox or a modified GENUINE ROTAX® Airbox for reasons of installation the certification has to be conducted.

⚠ WARNING

Non-compliance can result in serious injuries or death!

The furnishing of proof in accordance to the latest FAR and EASA, has to be conducted by the aircraft manufacturer.

Airbox retrofitted NOTE

If an airbox or GENUINE ROTAX® Airbox is retrofitted at a ROTAX® 912 (A, F, UL) Series, a change in the carb jetting is required.

See Illustrated Part Catalog 912/914 chapter “Bing constant speed depression carburetor” and/or SB-912-044 “Use of the ROTAX® supplied airbox”, latest issue

SYSTEM LIMITATIONS

Fuel-mixture distribution Low (cold) air temperature in the airbox is favorable for engine performance and to reduce knocking tendency at combustion.

⚠ WARNING

Non-compliance can result in serious injuries or death!

The furnishing of proof in accordance to the latest FAR and EASA, has to be conducted by the aircraft manufacturer.

ATTENTION

Any changes on the air intake system (e.g. modification on the airbox etc.) can affect the flow rate in the air intake system and fuel mixture ratio. In the course of certification the fuel mixture process must be proofed by a CO-measurement.

BRP-Rotax INSTALLATION MANUAL

CO-Measurement for configuration with non-GENUINE ROTAX® Airbox

	CO-Measurement
ROTAX® 912 A, F, UL	min. 2 % CO must be verified from aircraft manufacturer
ROTAX® 912 S, ULS	min. 3 % CO wide open throttle (WOT); a rpm of min. 5200 rpm needs to be achieved

- Measurement in original configuration of aircraft e.g. with installed cowling.
- Measured on each single cylinder.
- Measuring point is the same as the EGT measurement.
See [Chapter 78-00-00](#)

BRP-Rotax
INSTALLATION MANUAL

REQUIREMENTS ON THE AIR INTAKE SYSTEM

⚠ WARNING

Non-compliance can result in serious injuries or death!

Carb icing is a common reason for engine trouble. No implements are included in the supply volume for preheating of the intake air. If an airbox of non-ROTAX® origin is used provisions for preheating the intake air have to be made to prevent formation of ice in the intake system. Preheating of the intake air will result in performance loss because of the lower air density.

⚠ WARNING

Non-compliance can result in serious injuries or death!

The furnishing of proof in accordance to the latest FAR and EASA, has to be conducted by the aircraft manufacturer.

ATTENTION

All items of the air intake have to be secured against loss.

INTERFACE OVERVIEW

Fig. shows the GENUINE ROTAX® Airbox.

NOTE

Make sure that the air intake tubes of the airbox for fresh air and preheated air are connected correctly.

BRP-Rotax INSTALLATION MANUAL

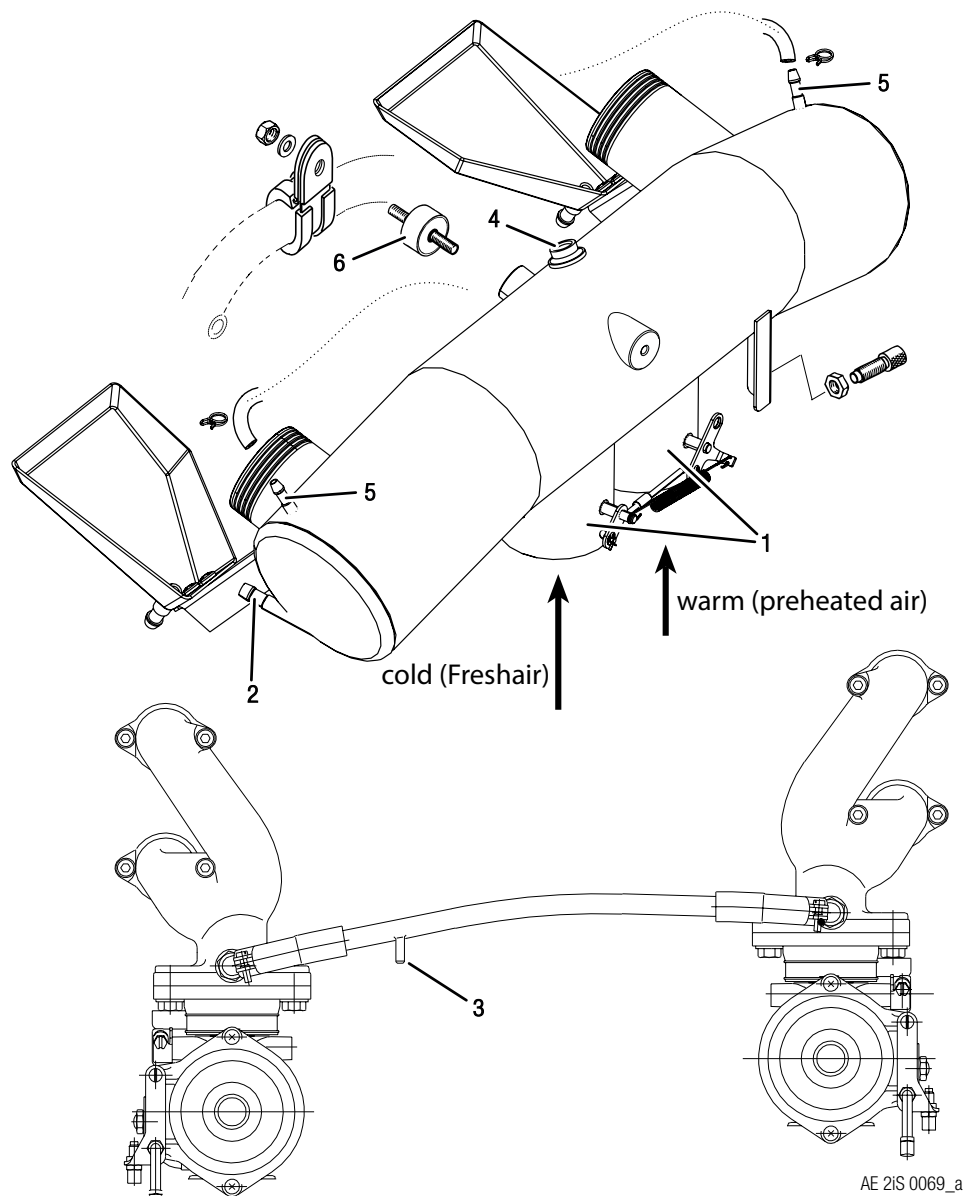

AE 2iS 0069_a

Figure 6.1: Airbox

- | | | | |
|---|--|---|-----------------------------------|
| 1 | Connection for freshair and pre-heated air | 2 | Leakage bore |
| 3 | Connection boost pressure | 4 | Connection for temperature sensor |
| 5 | Connection for float chamber venting lines | 6 | Rubber buffer |

BRP-Rotax INSTALLATION MANUAL

TECHNICAL DATA

ATTENTION
Prevent leakage! Utilize the full slip-on length for all connections. Secure hoses with suitable clamps or crimp connection.

ATTENTION
If the engine has been installed without employment of the optional ROTAX® engine frame which includes also support of the airbox, than provide an appropriately support for the airbox.

Manifold pressure

Provide connection to take readings of manifold pressure.

Connections

	Outside diameter	Slip-on length
Leakage bore	6 mm (1/4")	max. 17 mm (0.67 in.)
Temperature sensor	6 mm (1/4")	max. 17 mm (0.67 in.)
Connecting nipple of float chamber venting lines	6 mm (1/4")	max. 17 mm (0.67 in.)
Air intake socket for fresh air or pre-heated (intake side)	dia. 60 mm (2 3/8")	max. 25 mm (1 in.)

INTAKE AIR DUCTING

High engine performance needs air temperature as low as possible at air intake. Therefore the air filter should be located in a recess of the engine cowling or separated from warm air by baffles such that fresh air can be aspirated.

Technical data

Max. length of ducting	500 mm (20 in)
Inside diameter	Min. outside dia. of the intake socket on airbox
Min. mean bending radius	100 mm (4")

BRP-Rotax INSTALLATION MANUAL

AIR FILTER

BRP-Rotax offers an air filter as described below.

⚠ WARNING

Non-compliance can result in serious injuries or death!
Use only filter elements which will not tend to restrict the flow when in contact with water. Incorrect filter can result in freeze. This can lead to damage engine.

⚠ WARNING

Non-compliance can result in serious injuries or death!
The furnishing of proof in accordance to the latest FAR and EASA, has to be conducted by the aircraft manufacturer.

ATTENTION

A minimum flow rate has to be warranted for all conditions. The pressure loss must not exceed.

Minimum flow rate

A minimum flow rate of 220 m³/h (288 yd³/h, 129 CFM) has to be warranted for all conditions.

Pressure loss

The pressure loss must not exceed 2 hPa.

Choice of a suitable filter

The following points should assist the aircraft manufacturer at the choice of a suitable filter:

- 4 fold cotton fabric
- Surface covered with metal screen
- Total filter area at least 1400 cm² (217 in²)
- Min. flow rate of 6.23 m³/min (480 yd³/h, 282 CFM), based on the surface area of filter material

BRP-Rotax INSTALLATION MANUAL

AIRBOX

The airbox is furnished with 2 drain holes at the lowest position possible. The holes are necessary to drain fuel from flooding float chambers caused by leakage past float valve.

Volume At least 2.5 Liter (0.66 US gal)

Outline dimensions See [Fig. Airbox in Chapter 73-10-00 section Overview](#)

Drainage lines

⚠ WARNING

RISK OF FIRE! Non-compliance can result in serious injuries or death!
Connect drainage lines well, otherwise emerging fuel from a possible leakage could drip onto the exhaust system.

Requirements Observe the following requirements!

- The lines have to be routed such that in case of damage the surplus fuel is drained away suitably.
- Route the lines without kinks and avoid tight bends.
- Route the lines with a continuous decline.
- The lines have to be protected against any kind of blockage e.g. by formation of ice.

ATTENTION

RISK OF FIRE!

With closed or blocked drainage bores fuel could flow into combustion chamber, possibly ruining the engine by hydraulic lock or emerging fuel could drip onto the exhaust system.

ATTENTION

Pressure differences between intake pressure and pressure in the carburetor chambers may lead to engine malfunction due to incorrect fuel supply.

The float chamber venting lines have to be routed into a ram-air and vacuum free zone or into the GENUINE ROTAX® airbox, according to the requirements and release of BRP-Rotax. See also chapter "Carburetor". These lines must not be routed into the slipstream. If the drainage lines of the airbox are connected with the drainage lines of the drip trays or the carburetors by a T-piece, these lines must not be routed down the fire-wall (drainage lines of the airbox separately are allowed).

BRP-Rotax
INSTALLATION MANUAL

DATA FOR OPTIONAL COMPONENTS OF AIR INTAKE SYSTEM

Weight

For all optional components see [Chapter 72-00-00 section Weight](#)

Air filter

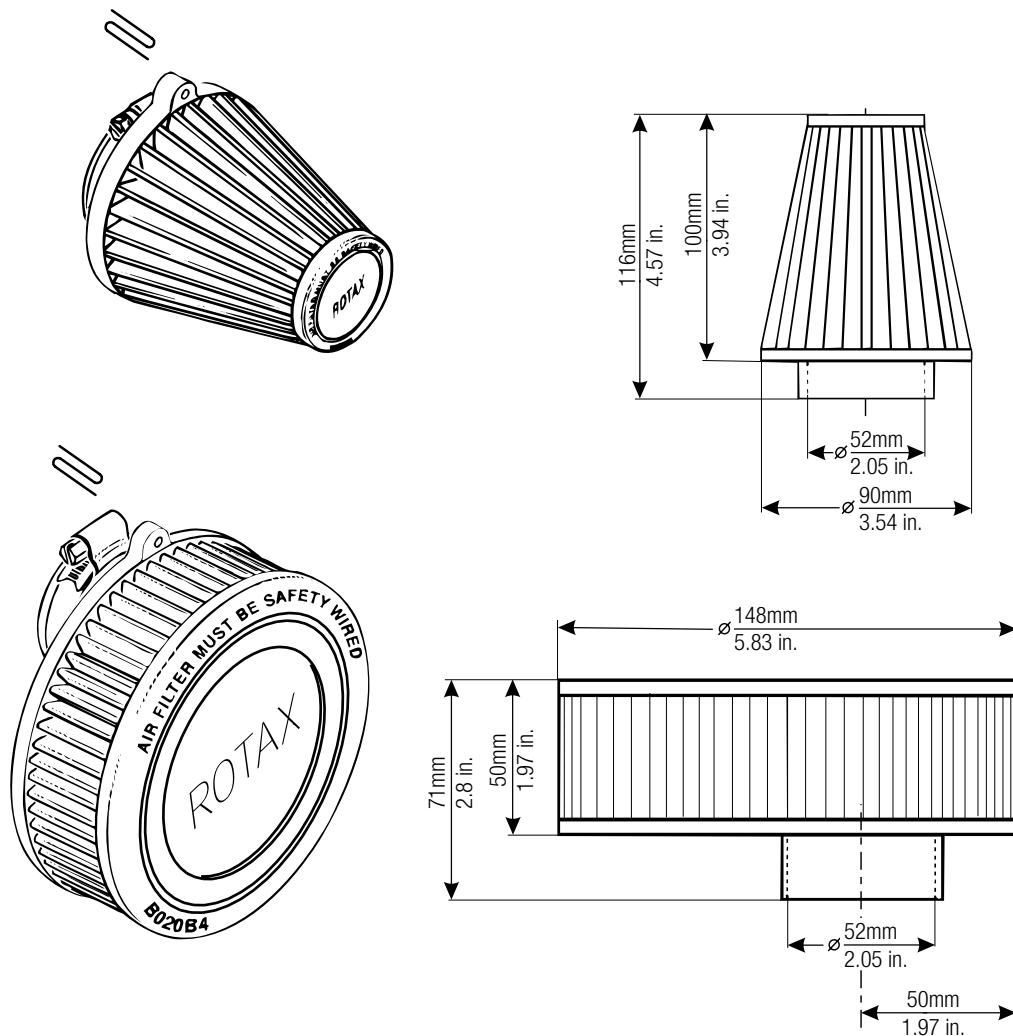

Figure 6.2: Air filter

BRP-Rotax INSTALLATION MANUAL

Airbox

Version part no. 867756

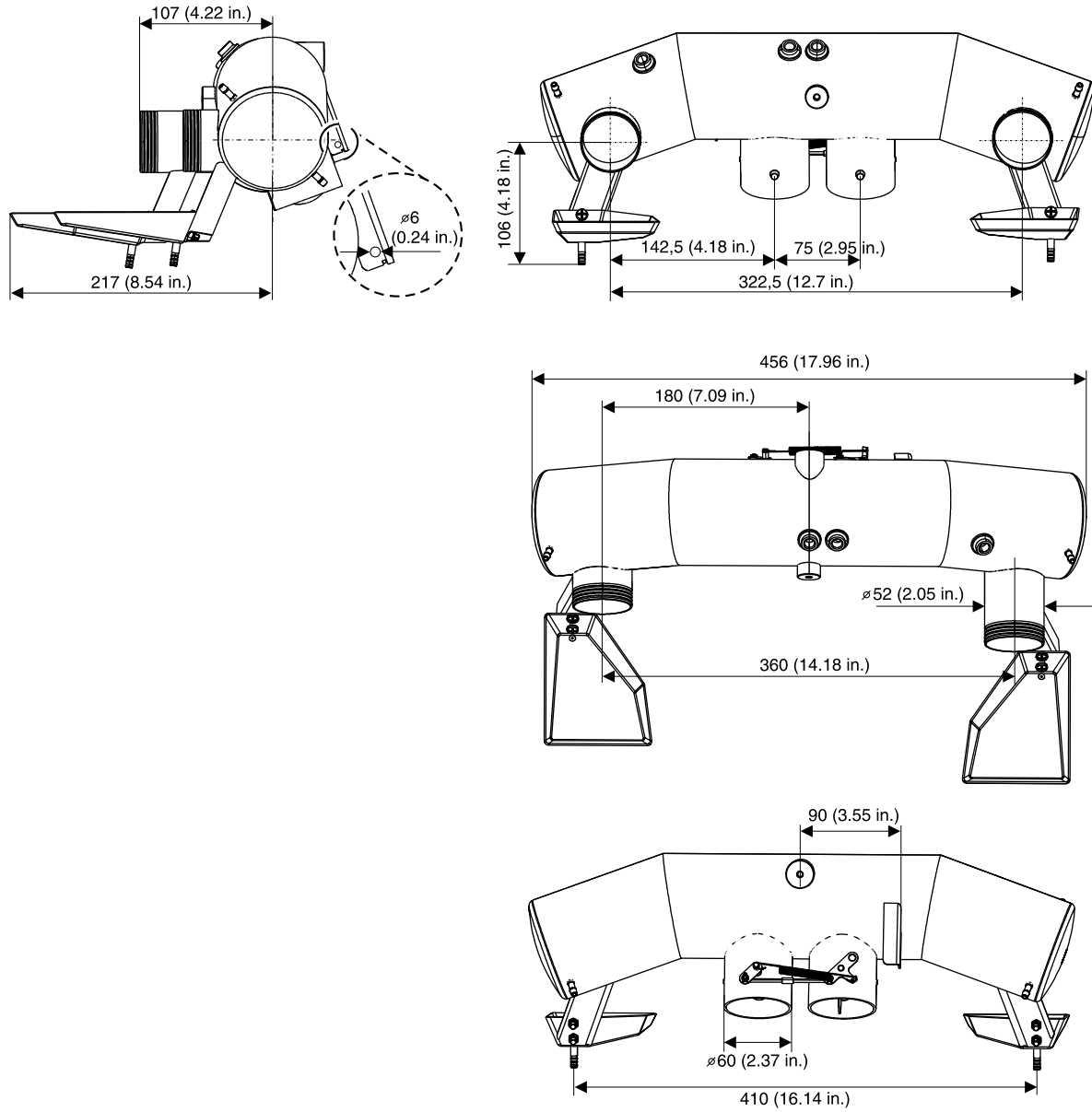

Figure 6.3: Airbox part no. 867756

BRP-Rotax INSTALLATION MANUAL

Airbox

New version part no. 667355
 Alte Ausführung TNr. 867756
 Old Version

Neue Ausführung TNr. 667355
 New Version

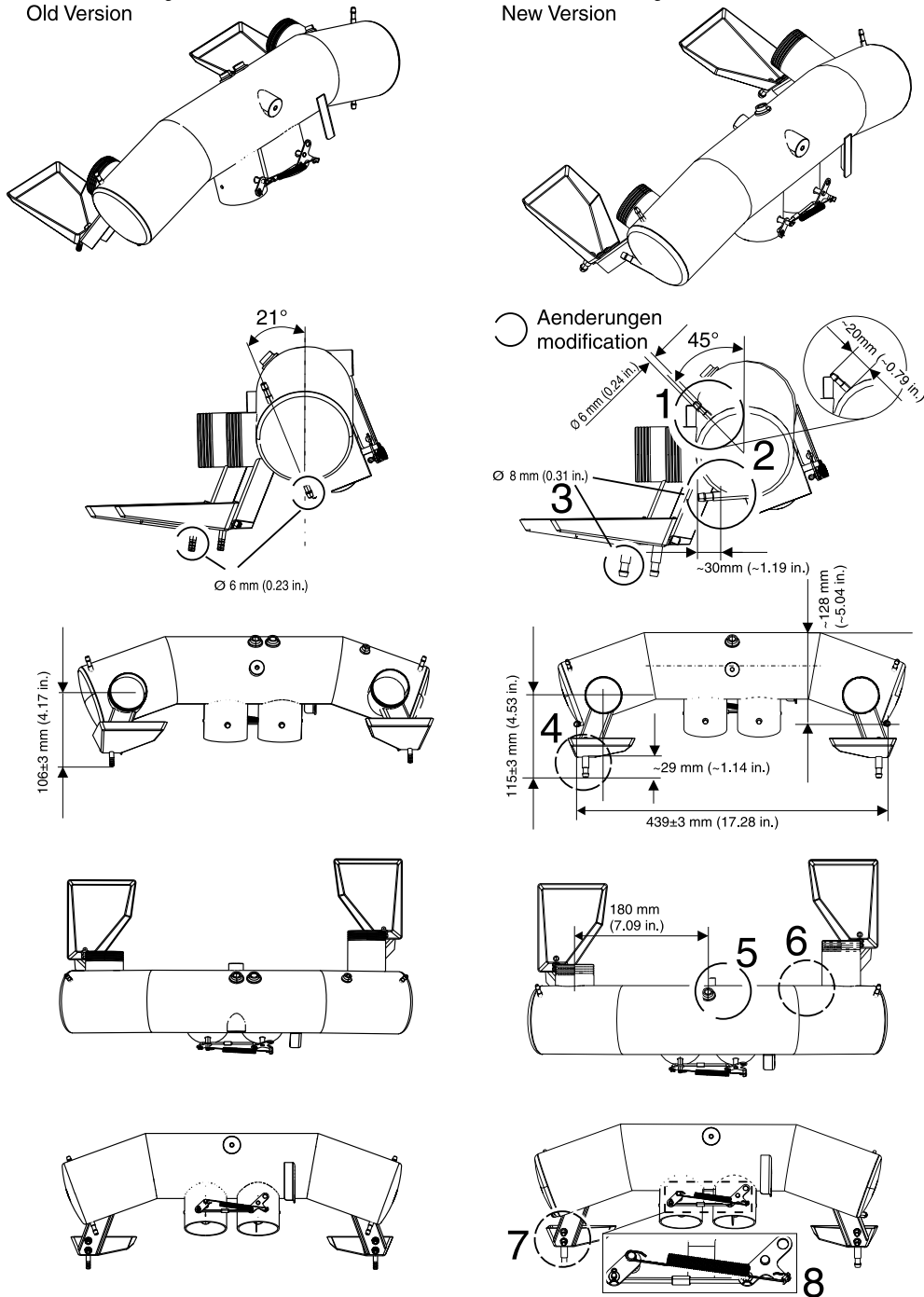

08646

Figure 6.4: Airbox part no. 667355 in comparison to the old version

BRP-Rotax
INSTALLATION MANUAL

INTENTIONALLY LEFT
BLANK

BRP-Rotax
INSTALLATION MANUAL

Chapter: 73-00-00
ENGINE – FUEL AND CONTROL

TOPICS IN THIS CHAPTER

Interface description	3
Interface overview	4
Requirements of the fuel system	5
Fuel temperature	5
Fuel pressure indicator	6
Fuel lines	6
Coarse filter	7
Water separator / Gascolator	7
Fine filter	7
Electrical fuel pump	7
GENUINE ROTAX® Fuel pump assy.	9
Fuel manifold	11
Drainage line	13
Carburetor	15
Requirements on the carburetor	15
Drainage lines on airbox and drip trays	17
Drainage piping on carburetor	18
Connections for throttle bowden cable actuation and permissible load	19
Technical Data	19
Requirements on Bowden cable actuation	21
Requirements on the throttle lever	22

BRP-Rotax
INSTALLATION MANUAL

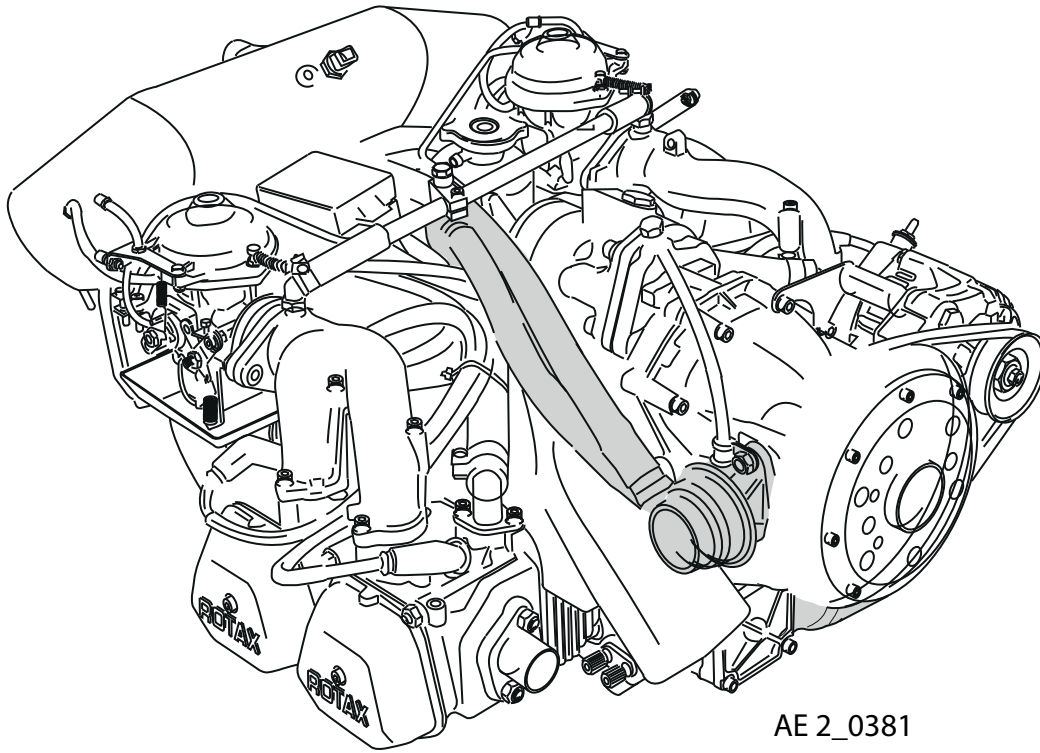

AE 2_0381

Figure 7.1: Fuel system

BRP-Rotax
INSTALLATION MANUAL

INTERFACE DESCRIPTION

ATTENTION

The design of the fuel system is the responsibility of the aircraft manufacturer. The fuel system must be designed to ensure that the engine is supplied with sufficient fuel at the correct pressure in every operational situation. Operating limits must be adhered to!

- Fuel** The fuel flows from the tank via a coarse filter and fire cock continue to water trap/fine to the mechanical fuel pump, from the pumps fuel passes on via the fuel manifold to the two carburetors.
- Fuel lines** Depending on the configuration of the engine the fuel lines from fuel pump to the carburetors are already installed by the manufacturer (optional on some engine). Only the following connections per following Fig. [Fuel system](#) have to be established:
- Feeding lines to suction side of the mechanical fuel pump.
 - Lines from pressure side of the mechanical fuel pump to inlet of fuel manifold.
 - Return line from fuel pressure control to fuel tank.
- Return line** Via the return line surplus fuel flows back to the fuel tank and suction side of fuel system.
- NOTE**
- The return line may prevent malfunctions caused by the formation of vapor lock.*
- Components** The fuel system includes the following items:
- Tank
 - Coarse filter
 - Fine filter / water trap
 - Fuel shut off valve / fire cock
 - Electrical fuel pump
 - Manometer
 - Return line from engine to tank (with integrated adapter sleeve) as well as the required fuel lines and connections

BRP-Rotax
INSTALLATION MANUAL

INTERFACE OVERVIEW

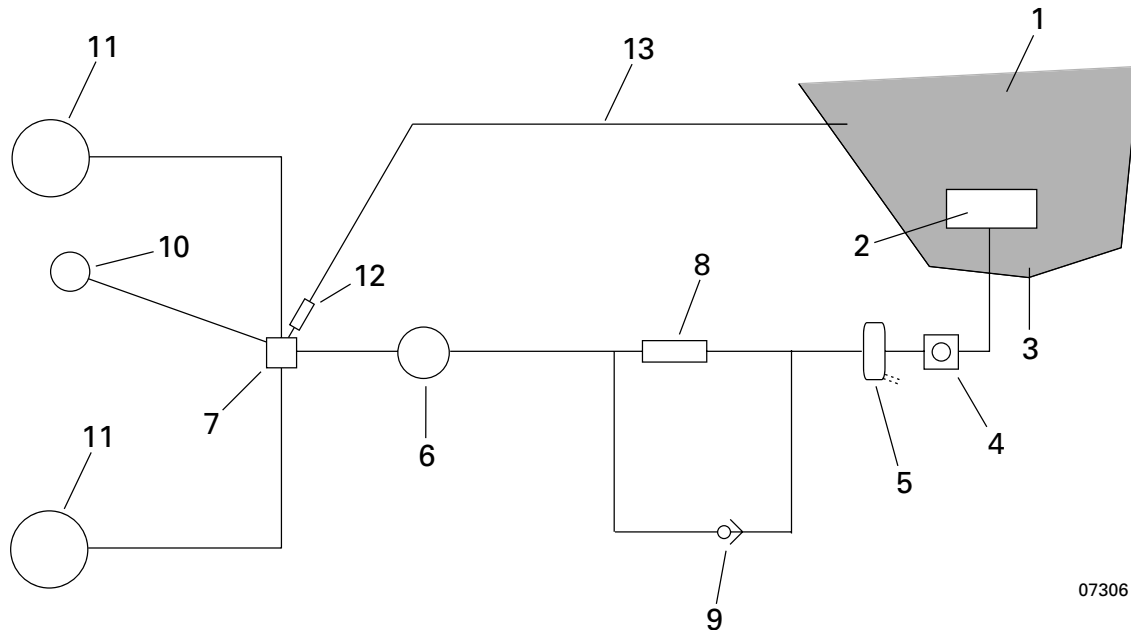

Figure 7.2: Fuel system

- | | | | |
|----|--|----|-----------------------------------|
| 1 | Fuel tank | 2 | Coarse filter |
| 3 | Drain valve | 4 | Fuel shut off valve / fire cock |
| 5 | Fine filter / water trap | 6 | Mechanical fuel pump ⁷ |
| 7 | Fuel pressure control ⁷ | 8 | Electrical fuel pump |
| 9 | Check valve | 10 | Fuel pressure gauge |
| 11 | Carburetor | 12 | Restrictor jet |
| 13 | Return line from engine to tank (with integrated restrictor orifice) | | |

7. Standard configuration

73-00-00

Page 4
January 01/2021

Effectivity: 912 Series
Edition 3/Rev. 0

BRP-Rotax INSTALLATION MANUAL

REQUIREMENTS OF THE FUEL SYSTEM

Operating limits



See Operating Manual 912 Series Chapter 2 section Operating limits.

ATTENTION

The design and layout of the entire fuel system must ensure engine operation within the specified operating limits.

In case of deviations in fuel pressure:

⚠ WARNING

Non-compliance can result in serious injuries or death!

The furnishing of proof in accordance to the latest FAR and EASA, has to be conducted by the aircraft manufacturer.

⚠ WARNING

Non-compliance can result in serious injuries or death!

Fuel pressure in excess of stated limit can lead to an override of the float valve with subsequent engine stop.

FUEL TEMPERATURE

The fuel system must be designed considering vapor lock depending on the ambient conditions (e.g. pressure and temperature) and the used fuel types (vapor pressure class). Vapor lock may result in engine stoppage.

Depending on the building regulations on aircraft level e.g. the “Hot Fuel Test” has to be passed.

Should problems occur during the test period, the affected components, e.g. the supply line to the fuel pumps, must be cooled.

BRP-Rotax INSTALLATION MANUAL

FUEL PRESSURE INDICATOR

NOTE

Readings of the fuel pressure are taken at the pressure gauge connection on the fuel distributor piece (standard for ROTAX® 912 F and 912 S, optional for other series).

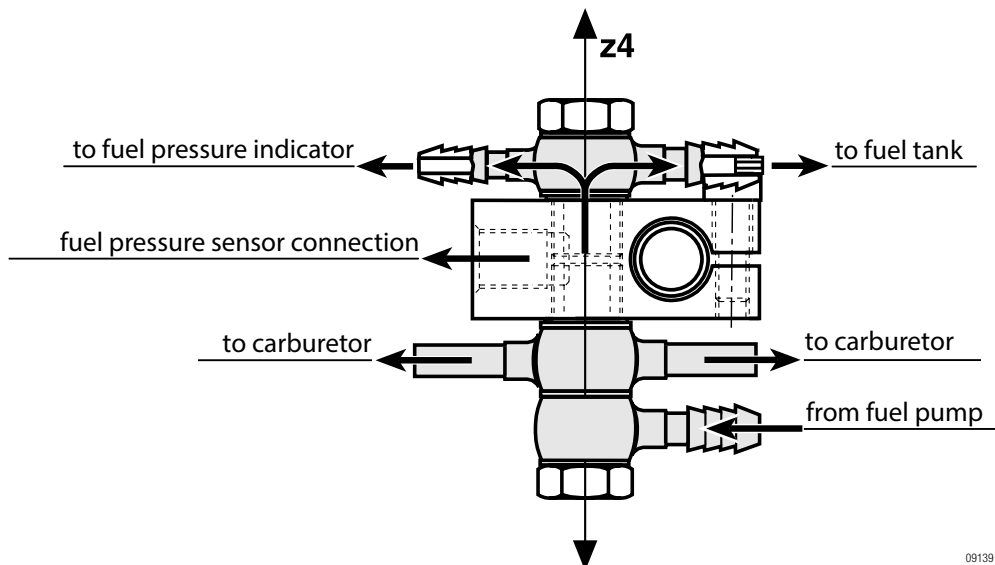

Figure 7.3: Fuel pressure

FUEL LINES

Safety

⚠ WARNING

Non-compliance can result in serious injuries or death!

The furnishing of proof in accordance to the latest FAR and EASA, has to be conducted by the aircraft manufacturer.

ATTENTION

For prevention of vapor locks:

All the fuel lines on the suction side of the fuel pump have to be insulated against heat in the engine compartment and routed at distance from hot engine components, without kinks and protected appropriately. At very critical conditions (e.g. problems with vapor formation) the fuel lines could be routed in a hose with cold air flow.

BRP-Rotax INSTALLATION MANUAL

Fuel return line

ATTENTION

The installation of a fuel return line is mandatory. If the fuel distributor piece with regulator from ROTAX® is not available, the fuel pressure must be regulated by a restriction in the fuel return line, which ensures that the fuel pressure is under all operating conditions within the operating limits specified by ROTAX®.

Screw clamp

ATTENTION

Prevent leakage!

Utilize the full slip-on length for all connections. Secure hoses with suitable clamps or crimp connection.

COARSE FILTER

On fuel tank as per valid certification.

WATER SEPARATOR / GASCOLATOR

The installation of a water separator/gascolator must be carried out by the aircraft or fuselage manufacturer and verified according to the latest regulations, such as FAR or EASA.

NOTE

A suitable water separator/gascolator must be installed at the lowest point of the fuel feed line.

FINE FILTER

⚠ WARNING

Do not use plastic filters in the engine compartment.
Only fire proof or fire resistant material can be used in the engine compartment.

⚠ WARNING

Do not use paper filters as they can absorb water.

In the feed line from tank to the fuel pumps an additional fine filter with mesh size 0.1 mm (70–100µ) has to be provided. The filter has to be accessible for service. A combination of filter/watertrap (gascolator) is recommended.

ELECTRICAL FUEL PUMP

The engine manufacturer recommends the use of an electrical auxiliary fuel pump, if this is not already required by airworthiness requirements.

BRP-Rotax INSTALLATION MANUAL

The electrical auxiliary fuel pump is not just required in case of a malfunction or defect of the mechanical fuel pump, but also provides required fuel supply e.g. in case of vapor formation at high altitudes and temperatures.

Operating Limits **NOTE**

If an electrical auxiliary fuel pump is installed, the whole fuel system has to be designed accordingly to warrant engine operation within the specified pressure limits.

ATTENTION

The fuel pressure of an additional auxiliary fuel pump should not exceed 0.31 bar (4.5 psi).

BRP-Rotax
INSTALLATION MANUAL

GENUINE ROTAX® FUEL PUMP ASSY.

ATTENTION

Ensure at installation of the supply line to fuel pump that no additional moments or load will rest on the pump!

ATTENTION

Prevent leakage!
Utilize the full slip-on length for all connections. Secure hoses with suitable clamps or crimp connection.

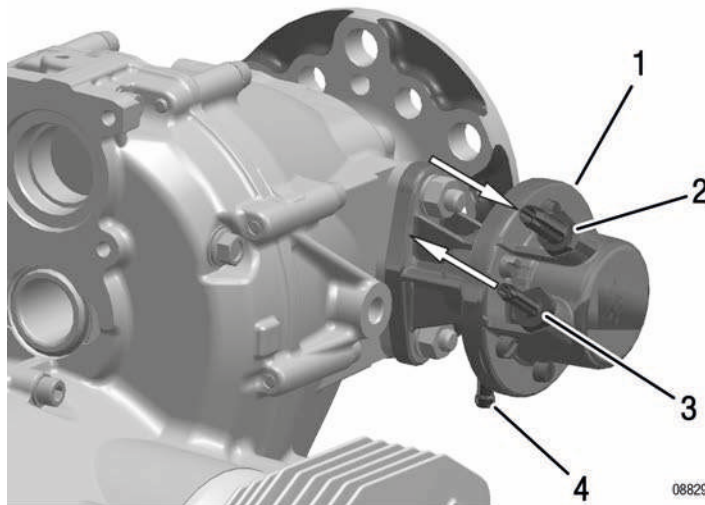

Figure 7.4: Fuel pump

- | | |
|--------------------------|--------------------------|
| 1 Fuel pump | 2 Fuel intake connection |
| 3 Fuel outlet connection | 4 Drainage |

Delivery rate electrical or mechanical fuel pump
min. 35 l/h (US 9.25 gal/h)

Slip-on joint

	Outside diameter	Slip-on length
Hose connection on fuel pump, fuel intake connection	8 mm (0.32 in.)	max. 22 mm (0.87 in.)
Fuel outlet connection	6 mm (0.24 in.)	max. 22 mm (0.87 in.)
Drainage	6 mm (0.24 in.)	max. 22 mm (0.87 in.)

BRP-Rotax INSTALLATION MANUAL

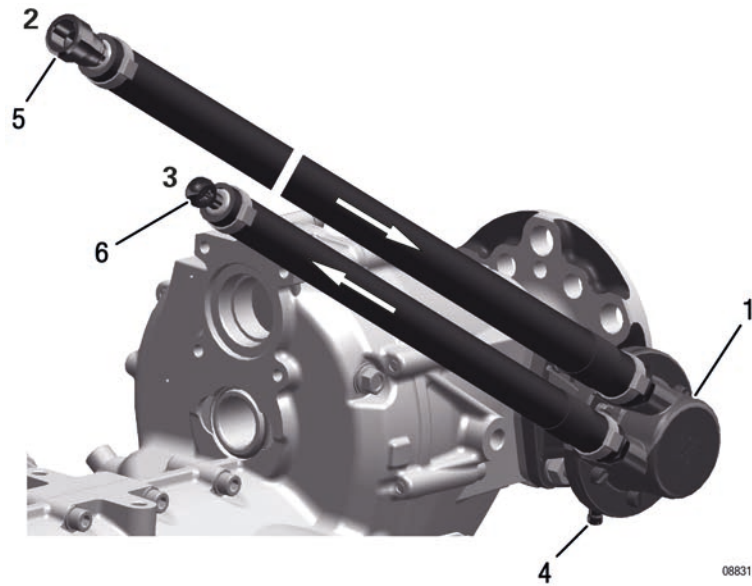

Figure 7.5: Sleeved lines

- | | |
|---|--|
| <p>1 Fuel pump</p> <p>3 Fuel outlet connection</p> <p>5 Fitting</p> | <p>2 Fuel intake connection</p> <p>4 Drainage</p> <p>6 Hose nipple</p> |
|---|--|

Screw connection

	Hose connection	Tightening torque
Hose connection on fuel pump, fuel intake connection	9/16–18 UNF (AN-6) (Fitting)	15 Nm (135 in lb)
Fuel outlet connection	3/4 DIN 7642 (Hose nipple)	15 Nm (135 in lb)
	Outside diameter	Slip-on length
Drainage	6 mm (0.24 in.)	max. 22 mm (0.87 in.)

BRP-Rotax
INSTALLATION MANUAL

FUEL MANIFOLD

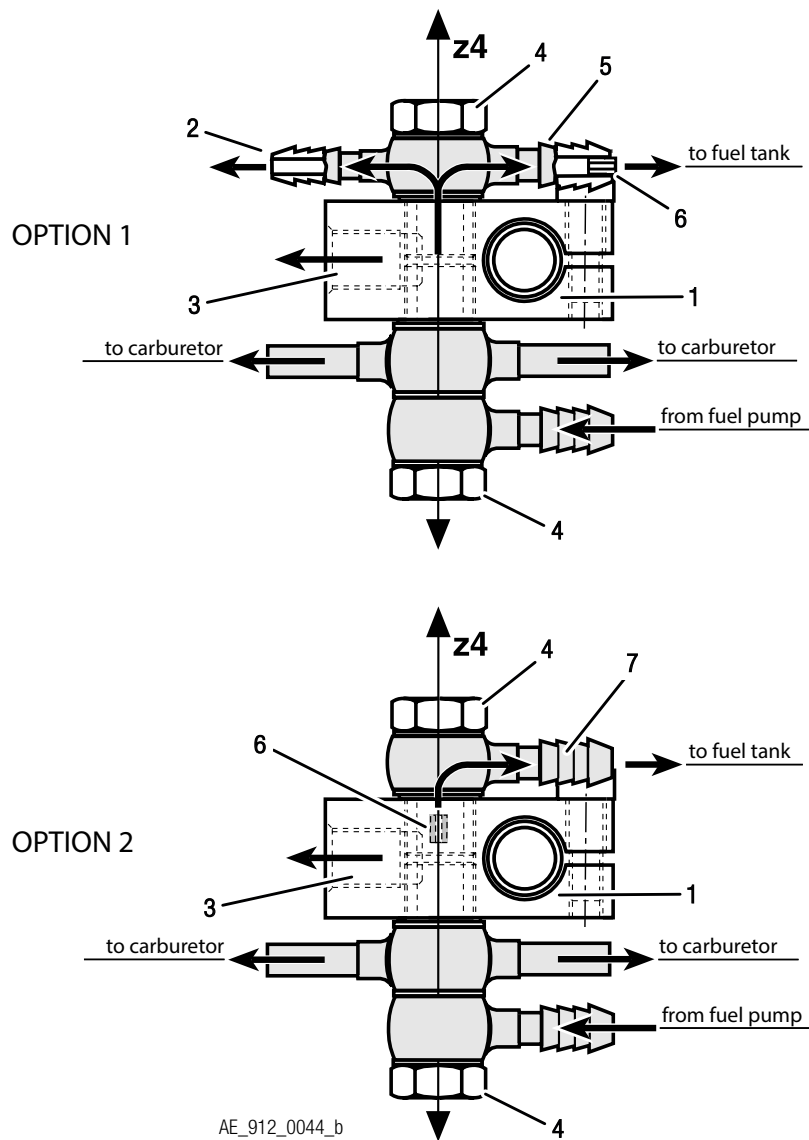

Figure 7.6: Fuel manifold

- | | |
|-----------------------------------|-------------------------------------|
| 1 Fuel manifold | 2 Pressure gauge connection |
| 3 Fuel pressure sensor connection | 4 Banjo bolt |
| 5 Connection nipple | 6 Integrated orifice (PILOT JET 35) |
| 7 Hose nipple | |

BRP-Rotax INSTALLATION MANUAL

Hose connections

	Outside diameter	Slip-on length
Return line to tank	7 mm (0.28 in.)	max. 17 mm (0.67 in.)
Pressure gauge	6 mm (0.24 in.)	max. 17 mm (0.67 in.)

	Thread	Thread length
Fuel pressure sensor	M10	max. 9 mm (0.35 in.)

Banjo bolt

ATTENTION
At loosening or tightening of the banjo bolt (tightening torque 10 Nm = 90 in.lb) support the fuel manifold appropriately.

Connection nipple

The connection nipple is furnished with an orifice (0.5 mm = 0.0197 in.) essential for operation of the fuel system.
If the pressure gauge connection is not used and a hose nipple installed, the banjo bolt assy. marked with a color dot or marked "FUEL" is furnished with an orifice (0.5 mm = 0.0197 in.). This is essential for operation of the fuel system as it will prevent a loss in fuel pressure.

Coordinates

Position of z4 axis of fuel manifold

NOTE

All distances are given in relation to the reference coordinate system (P).

	x-axis	y-axis	z-axis
Fuel manifold	-385.0 mm (15.16 in.)	-50.0 mm (-1.97 in.)	approx. 110 mm (4.33 in.)

BRP-Rotax INSTALLATION MANUAL

DRAINAGE LINE

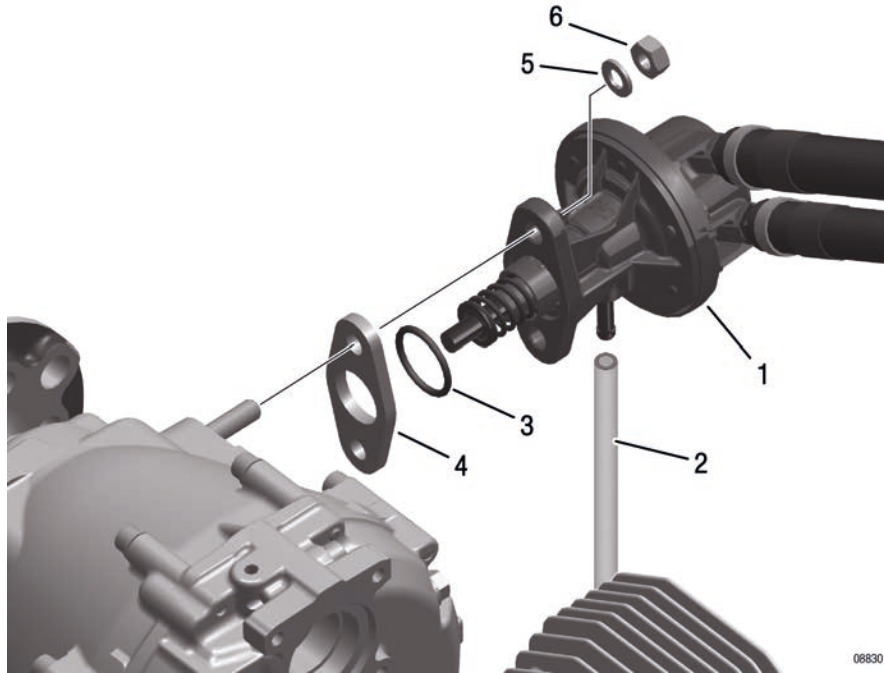

Figure 7.7

Part	Function
1	Fuel pump
2	Drainage line/hose
3	O-ring
4	Insulating flange (gasket)
5	Lock washer A8
6	Hex. nut M8

ATTENTION

Route the lines without kinks and avoid tight bends.

ATTENTION

Observe correct routing of drainage line.

Drainage line have to be routed into a ram-air and vacuum free zone, according to the requirements and release of BRP-Rotax. The drainage line must not be routed into the slipstream. Ram pressure or vacuum impair the fuel pressure.

BRP-Rotax

INSTALLATION MANUAL

- The lines have to be routed such that in case of damage the surplus of fuel/oil is drained off suitably
- Route the lines with a continuous decline
- The lines have to be protected against any kind of blockage e.g. by formation of ice

BRP-Rotax INSTALLATION MANUAL

CARBURETOR

⚠ WARNING

Non-compliance can result in serious injuries or death!

The carburetor flange assembly has to carry the weight of the carburetor and intake system. Ensure that the screw of the clamp is positioned on the underside as supplied and the gap between the clamp plates is 8 mm (.31 in.).

The carburetors on the standard engine are already attached by a flexible flange (and connecting hoses on the airbox). Only connections of the Bowden cable for preheating, choke and throttle have to be established.

It is recommended, to make the adjustment of the Bowden cable after engine installation has been completed, to ensure exact final adjustment.

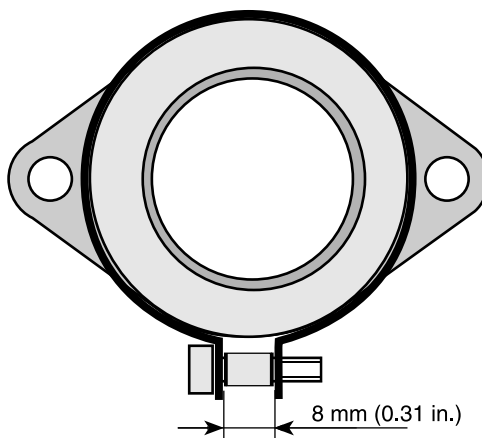

Figure 7.8: Carburetor socket

REQUIREMENTS ON THE CARBURETOR

⚠ WARNING

Non-compliance can result in serious injuries or death!

In the area of the float chamber the temperature limit of the fuel must not be exceeded. If necessary install additional insulation or heat shields.

⚠ WARNING

Non-compliance can result in serious injuries or death!

The furnishing of proof in accordance to the latest FAR and EASA, has to be conducted by the aircraft manufacturer.

BRP-Rotax INSTALLATION MANUAL

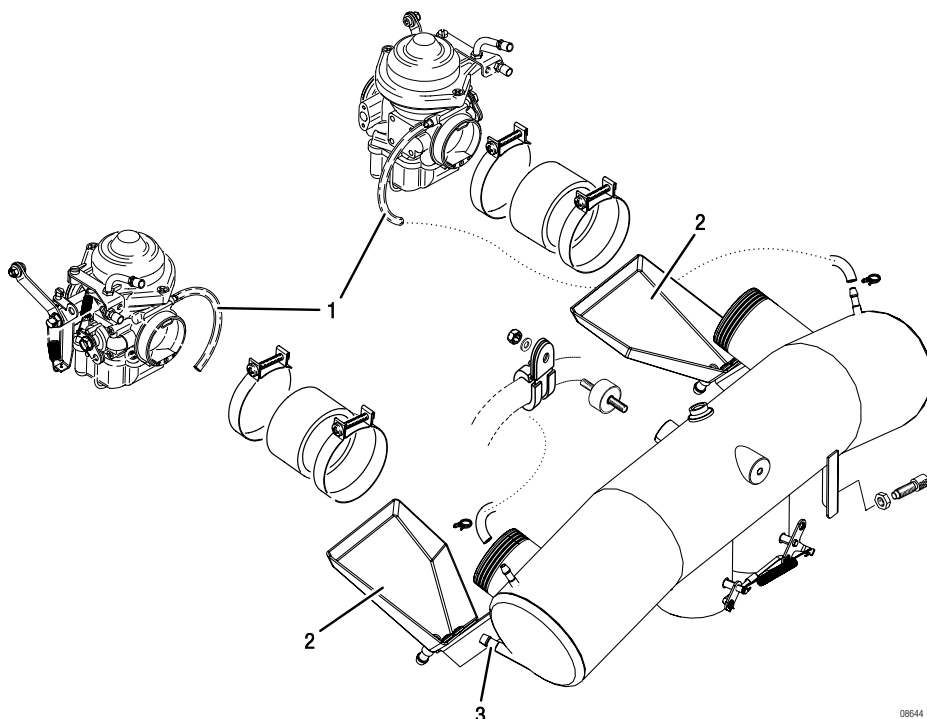

Figure 7.9: Drip tray and draining connection

- 1 *Float chamber venting lines*
- 2 *Drip tray*
- 3 *Draining connection*

Drip tray

The carburetors are positioned above the exhaust sockets. Below the carburetors one each drip tray with a draining connection is fitted which serves as a heat shield as well.

Float chamber venting lines

ATTENTION

Pressure differences between intake pressure and pressure in the carburetor chambers may lead to engine malfunction due to incorrect fuel supply.

The float chamber venting lines have to be routed into a ram-air and vacuum free zone or into the GENUINE ROTAX® airbox, according to the requirements and release of BRP-Rotax. See also chapter "Carburetor". These lines must not be routed into the slip-stream. If the drainage lines of the airbox are connected with the drainage lines of the drip trays or the carburetors by a T-piece, these lines must not be routed down the fire-wall (drainage lines of the airbox separately are allowed).

Connecting nipple for leakage line

	Outside diameter	Slip-on length
Slip-on joint	6 mm (0.24 in.)	max. 17 mm (0.67 in.)

BRP-Rotax INSTALLATION MANUAL

DRAINAGE LINES ON AIRBOX AND DRIP TRAYS

⚠ WARNING

RISK OF FIRE! Non-compliance can result in serious injuries or death!
Connect drainage lines well, otherwise emerging fuel from a possible leakage could drip onto the exhaust system.

ATTENTION

Pressure differences between intake pressure and pressure in the carburetor chambers may lead to engine malfunction due to incorrect fuel supply.
The float chamber venting lines have to be routed into a ram-air and vacuum free zone or into the GENUINE ROTAX® airbox, according to the requirements and release of BRP-Rotax. See also chapter "Carburetor". These lines must not be routed into the slipstream. If the drainage lines of the airbox are connected with the drainage lines of the drip trays or the carburetors by a T-piece, these lines must not be routed down the fire-wall (drainage lines of the airbox separately are allowed).

Requirements

- The lines have to be routed such that in case of damage the surplus fuel is drained off suitably.
- Route the lines without kinks and avoid tight bends.
- Route the lines with a continuous decline.
- The lines have to be protected against any kind of blockage e.g. by formation of ice.

BRP-Rotax INSTALLATION MANUAL

DRAINAGE PIPING ON CARBURETOR

⚠ WARNING

RISK OF FIRE! Non-compliance can result in serious injuries or death!
Connect drainage lines well, otherwise emerging fuel from a possible leakage could drip onto the exhaust system.

The primary function of the carburetor float chamber venting lines, is to provide ambient air pressure to the float bowl chambers. However, it is possible for fuel to be expelled from these lines. Normally these lines are connected to fitting on the airbox to provide the ideal ambient air pressure and away of draining any expelled fuel overboard.

Drainage piping If an airbox is not installed, the vent lines will need to be routed according to the following instructions:

- The lines have to be routed such that in case of damage the surplus fuel is drained off suitably.
- Route the lines without kinks and avoid tight bends.
- Route the lines with a continuous decline.
- The lines have to be protected against any kind of blockage e.g. by formation of ice.

ATTENTION

Pressure differences between intake pressure and pressure in the carburetor chambers may lead to engine malfunction due to incorrect fuel supply.

The float chamber venting lines have to be routed into a ram-air and vacuum free zone or into the GENUINE ROTAX® airbox, according to the requirements and release of BRP-Rotax. See also chapter "Carburetor". These lines must not be routed into the slip-stream. If the drainage lines of the airbox are connected with the drainage lines of the drip trays or the carburetors by a T-piece, these lines must not be routed down the fire-wall (drainage lines of the airbox separately are allowed).

BRP-Rotax
INSTALLATION MANUAL

CONNECTIONS FOR THROTTLE BOWDEN CABLE ACTUATION AND PERMISSIBLE LOAD

ATTENTION
The specified permissible loads must never be exceeded!

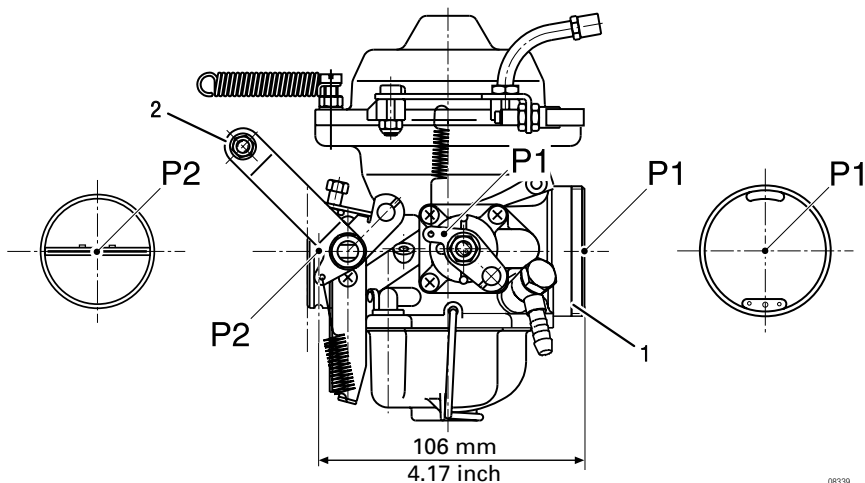

Figure 7.10: Connections Cable actuation

- 1 Connection for airbox or air filter 2 Connection for throttle actuation
P1 Centre position of carburetor socket P2 Point of reference

TECHNICAL DATA

See [Figure 7.10: Connections for Bowden cable actuation](#)

Coordinates P1 Centre position of carburetor socket (P1) of the respective carburetor:

Carburetor for	x-axis	y-axis	z-axis
Cylinder 1/3	-521 mm (20.52 in)	-180 mm (-7.1 in)	25 mm (0.988 in)
Cylinder 2/4	-553 mm (-21.77 in)	180 mm (7.1 in)	25 mm (0.988 in)

Reference point P2 Limit load on point of reference P2:

	Reference point P2
max. permissible forces (limit load) in x, y and z-axis	60 N (13.5 lbf)
max. permissible bending moments (limit load) in x, y and z-axis	4 Nm (35 in. lb)

BRP-Rotax INSTALLATION MANUAL

Connection for air filter or intake silencer

Outside diameter:	50 mm (2 in.)
Slip-on length:	12 mm (0.47 in.)

Connection for throttle actuation

Set screw	M5x12
Tightening torque	4 Nm (35 in lb) (suitable for 1.5 mm (0.06 in) steel wire or flexible wire)
Action travel	65 mm (2.56 in.)
Actuating force	min. 1.5 N (0.34 lbf) max. 8 N (1.79 lbf)
Limit load per carburetor	20 N (4.5 lbf)

NOTE

Throttle opens by spring.

Choke actuation

NOTE

The choke shaft is marked. This mark has to point towards cable engagement.

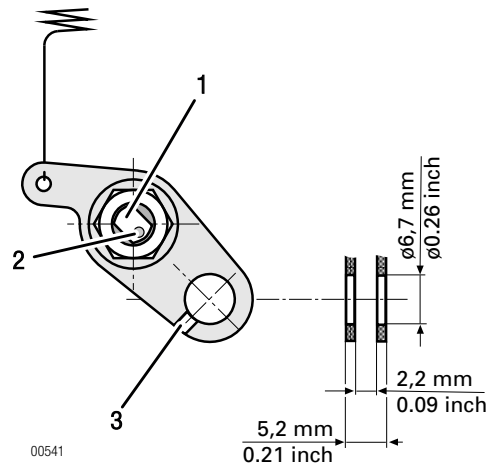

Figure 7.11: Choke actuation

- | | | | |
|---|------------------|---|---------|
| 1 | Choke shaft | 2 | Marking |
| 3 | Cable engagement | | |

BRP-Rotax INSTALLATION MANUAL

Connection for choke actuation

Clamping nipple:	6 (suitable for 1.5 mm (0.06 in) flexible wire or steel wire)
Action travel:	23 mm (0.91 in)
Actuating force:	min. 10 N (2.24 lbf) max. 45 N (10.11 lbf)
Limit load:	100 N (22.48 lbf)

REQUIREMENTS ON BOWDEN CABLE ACTUATION

⚠ WARNING

Non-compliance can result in serious injuries or death!

With throttle lever not connected the throttle valve will remain fully open. The starting position of the throttle valve is therefore full throttle! Therefore never start the engine without connecting the throttle lever first.

⚠ WARNING

Non-compliance can result in serious injuries or death!

The cable actuations being used must not be affected at all by vibrations emanating from the engine or the airframe.

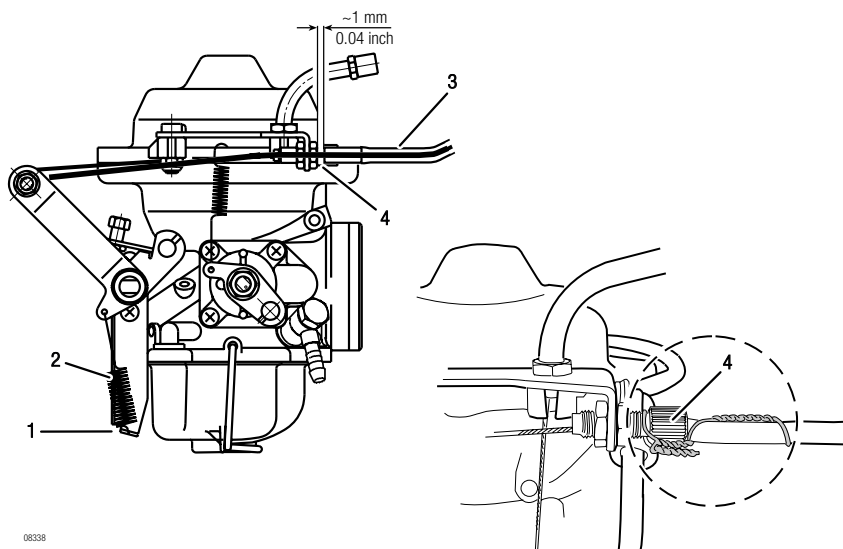

Figure 7.12: Bowden cable actuation

- | | | | |
|---|---------------|---|-------------------|
| 1 | Lever flap | 2 | Return spring |
| 3 | Cable sleeves | 4 | Adjustment screws |

BRP-Rotax INSTALLATION MANUAL

Bowden cable The two throttles have to be controlled by two separate Bowden cables working synchronously.
Adjust the cables to a free travel of 0.04 in.

⚠ WARNING

Non-compliance can result in serious injuries or death!

Use Bowden cable with minimized friction so that the spring on the throttle can open the throttle completely. Otherwise fit a stronger return spring or a cable with pull-push action would have to be used. Secure the Bowden cable sleeves in the adjustment screws (e.g. safety wire).

REQUIREMENTS ON THE THROTTLE LEVER

Mechanical stops Adjustable positive stops for idle- and full throttle position are of course required. These stops have to be designed such to render adjustability and to prevent overload of the idle stop on the carburetor.
The sketch depicts a feasible arrangement.

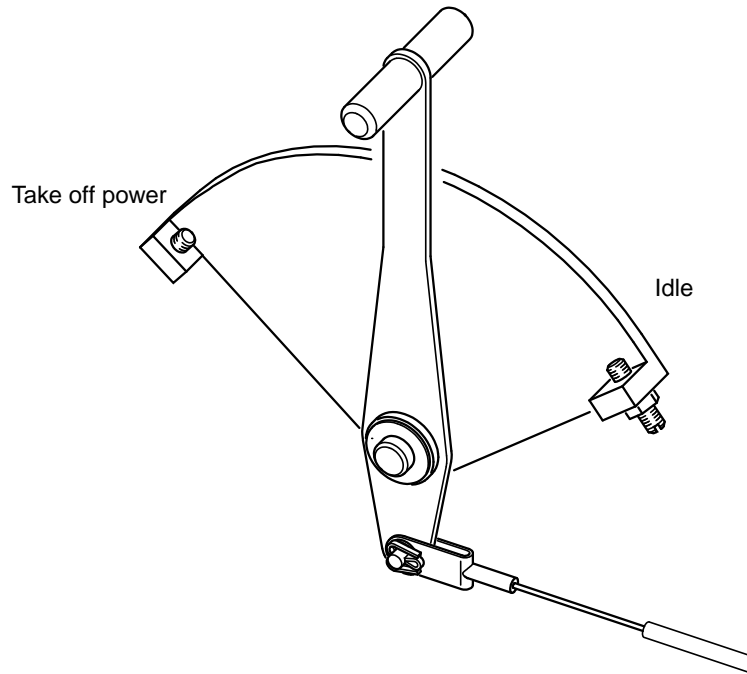

Figure 7.13: Throttle lever feasible arrangement

BRP-Rotax
INSTALLATION MANUAL

Chapter: 75-00-00
COOLING SYSTEM

TOPICS IN THIS CHAPTER

Interface overview	2
Installation overview	3
System limitations	3
Operating limits	4
Coolant types	5
Checking the efficiency of the cooling system	8
Determination of operating limits, Coolant and necessary modification on radiator installation for engine	12
Coolant hoses	14
Connecting size and position of connections	15
Requirements, permissible location and installation position	18
General notes on the cooling system	20
Coolant capacity	21
Mechanical interfaces	22
Overflow bottle from ROTAX® (optional available)	24
Air cooling interfaces	26

BRP-Rotax
INSTALLATION MANUAL

INTERFACE OVERVIEW

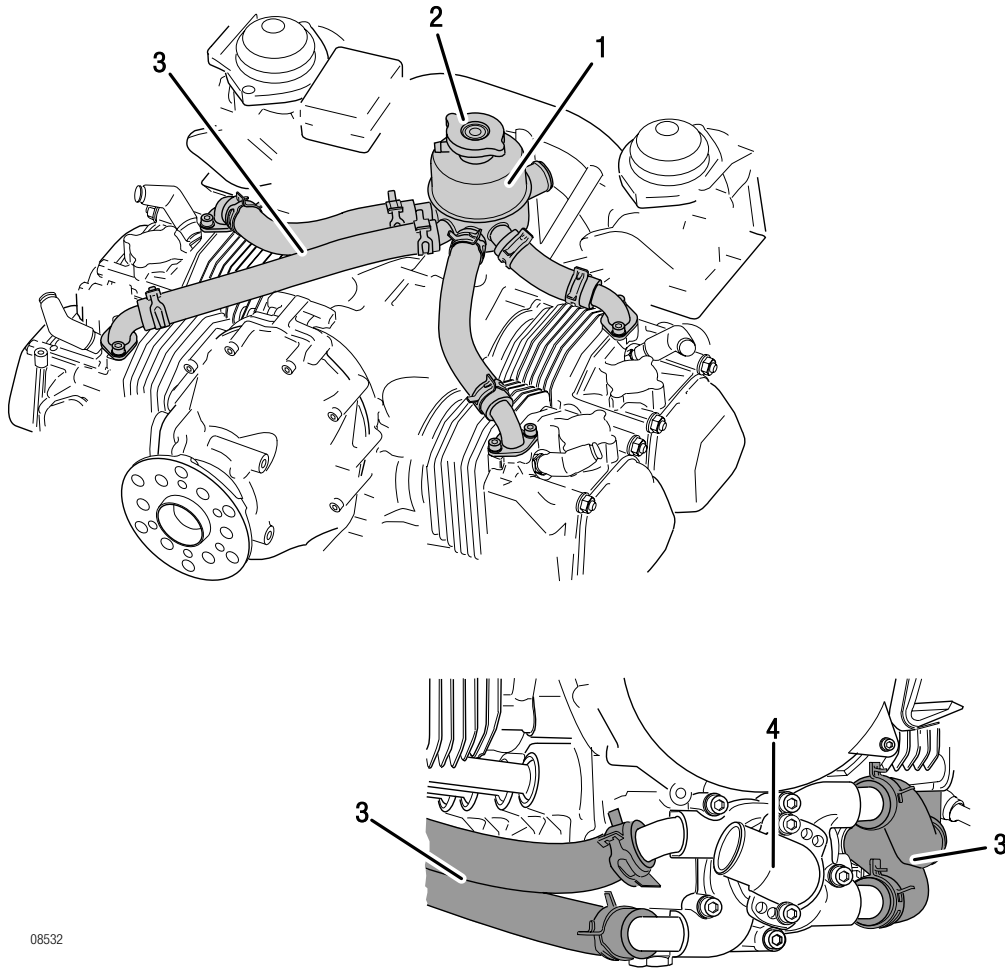

08532

Figure 8.1: Cooling system

- 1 Expansion tank
- 3 Coolant hose

- 2 Radiator cap
- 4 Water pump

BRP-Rotax INSTALLATION MANUAL

INSTALLATION OVERVIEW

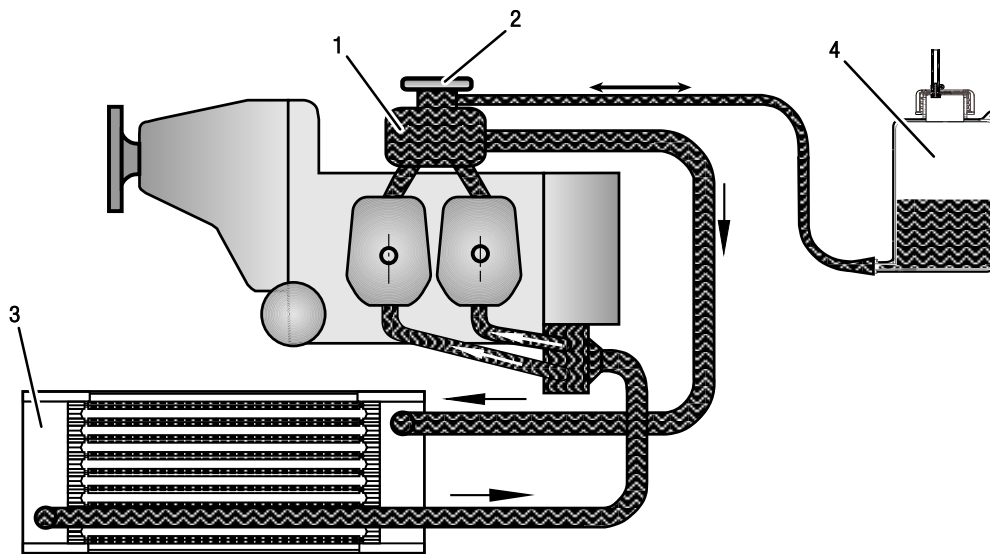

09152

Figure 8.2: Cooling system

1 Expansion tank

2 Pressure cap

3 Radiator

4 Overflow bottle

SYSTEM LIMITATIONS

Operating limits



Refer to latest issue of the Operators Manual .

⚠ WARNING

Non-compliance can result in serious injuries or death!

The cooling system must be designed so that the operating limits are not exceeded. To minimize flow resistance, use radiators that have both a parallel flow and have a low flow resistance. A prime example would be the GENUINE ROTAX® radiators. Be sure to use short hoses and pipelines.

Cooling

The engine cooling system is designed for liquid cooling of the cylinder heads and ram air cooling of the cylinders.

The cooling system of the cylinder heads is a closed circuit with an expansion tank and overflow bottle.

Coolant

The coolant flow is forced by a water pump, driven from the camshaft, from the radiator to the individual cylinder heads. The coolant flows from the top of the cylinder heads to the expansion tank. Since the standard location of the radiator is below engine level, the expansion tank located on top of the engine allows for coolant expansion.

BRP-Rotax

INSTALLATION MANUAL

Expansion tank	The expansion tank is closed with a pressure cap (with pressure relief valve and return valve). As the coolant heats up and expands, the pressure relief valve opens and the coolant flows via hose at atmospheric pressure to the transparent overflow bottle. As it cools down, the coolant is sucked back into the cooling circuit.
Shape, size and position	The shape, size and position of the radiator(s) depends mainly on the space available in the aircraft.
Measuring the coolant temp.	Readings are taken on measuring point of the hottest cylinder head, depending on engine installation. The temperature sensors are located in cylinder head 2 and 3.
Radiator	If a GENUINE ROTAX® radiator is being used, then an oil-water heat exchanger must not be present. The radiator is dimensioned to cater for the heat of the coolant and cannot cope with the additional heat generated by the oil system.

OPERATING LIMITS

General For operating limits see latest Operators Manual of the respective engine type.

⚠ WARNING

Non-compliance can result in serious injuries or death!

The cooling system must be designed so that operating temperatures will not exceed the maximum values.

“Boiling point of the coolant” Monitoring the cooling system is important for controlling engine cooling and to prevent knocking combustion within the operating limits. It is important that the coolant circuit is designed so that the coolant does not reach boiling point under any conditions. If the temperature exceeds the boiling point, the engine can quickly overheat due to loss of coolant.

NOTE

Permanent monitoring of coolant temperature is necessary.

The boiling point of the coolant is mainly influenced by:

- the type of coolant (not for Suffix -01)
- mixture ratio (percentage water rate)
- the system pressure (opening pressure of radiator cap)

Correlation between coolant temperature and cylinder head temperature

There is in principle a regular relationship between coolant temperature and cylinder head temperature. The coolant transfers some of the combustion heat to the radiator. Thus, the coolant temperature is usually lower than the cylinder head temperature. But the temperature difference between coolant and cylinder head is not constant and can vary with different engine installation (cowling or free installation, tractor or pusher, flight speed, etc.).

NOTE

The basic requirement for safe operation is that boiling of conventional coolant must be prevented. The boiling point of conventional coolant is 120 °C (248 °F) with a 50/50 mixture proportion and a system pressure of 1.2 bar (18 psi).

BRP-Rotax INSTALLATION MANUAL

COOLANT TYPES

Without Suffix -01 Permissible coolant types:

- Conventional coolant based on ethylene glycol
- Waterless coolant based on propylene glycol

ATTENTION

When selecting a suitable coolant, the information in Service Instruction SI-912-016, latest issue, must be observed.

Conventional coolant Conventional coolant is recommended as it commonly available and has a greater thermal heat transfer capability. Its limitation is its lower boiling point.

Waterless coolant Waterless coolant is recommended if the design of the aircraft can not maintain the coolant temperature limit 120 °C (248 °F).

Mixing ratio

ATTENTION

Obey the manufacturers instructions!

Description	Mixture ratio	
	Concentration	Water
Conventional coolant	50 %	50 %
Some conventional coolants are available pre-mixed by the manufacturer. In this case do not mix with water, instead follow the manufacturers instructions.		
Waterless coolant	100 %	0

Boiling point

- **Conventional coolant**
Conventional coolant with a rate of 50 % water cannot boil at a temperature below 120 °C (248 °F) at a pressure of 1.2 bar (18 psi). The max. coolant temperature limit is therefore 120 °C (248 °F).

NOTE

Permanent monitoring of cylinder head temperature (with Suffix -01: coolant temperature) is necessary.

- **Waterless coolant**
Waterless coolant has a very high boiling point that prevents coolant loss due to “boiling over“ (vapor loss), but not to prevent detonation, which can occur with cylinder head temperatures higher than 135 °C (275 °F) . It does not require pressure to maintain its boiling point. Due to a lower thermal conductivity the engine temperature will typically run about 5-10 °C (9- 18 °F) higher with waterless coolant.

BRP-Rotax INSTALLATION MANUAL

NOTE

*Permanent monitoring of cylinder head temperature is necessary.
Additional monitoring of the actual coolant temperature is possible but not necessary for waterless coolant.*

NOTE

When using EVANS NPGR, NPG+ or added pure ethylene glycol as a coolant, note that these fluids have a flammability rating 1 (classification LOW at a scale from 0 to 4). The mentioned coolants are complying according to their material safety data sheet with a flammability classification, which has only low danger and a low risk of flammability. To date, no cases in engine operation or flight operation, laboratory conditions or from the field were reported, which show unsafe conditions of ROTAX® aircraft engines in combination with the relevant coolants.

Marking

ATTENTION

The coolant to be used and its concentration (percentage water rate) must be correctly communicated to the owner. Waterless coolant must not mix with water, as otherwise it will lose the advantages of a high boiling point.

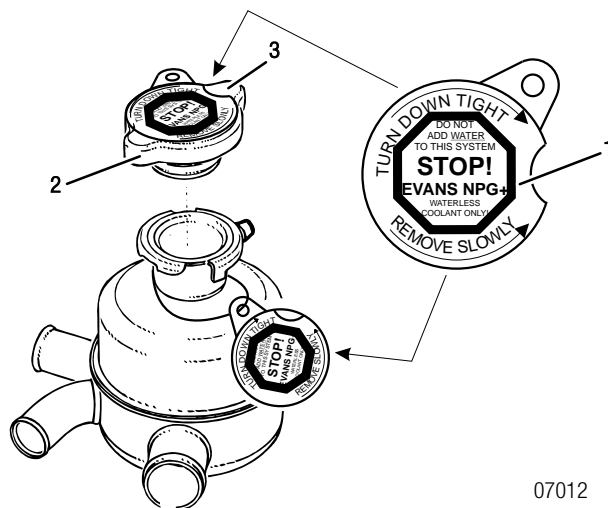

Figure 8.3: :Marking of the coolant

- 1 Warning sticker
- 2 Radiator cap
- 3 Opening pressure information of radiator cap

BRP-Rotax INSTALLATION MANUAL

Suffix -01

Permissible coolant types:

- Conventional coolant based on ethylene glycol

ATTENTION

Obey the latest edition of Service Instruction SI-912-016, for the selection of the correct operating media.

Conventional coolant is recommended as it commonly available and has a greater thermal heat transfer capability. Its limitation is its lower boiling point.

NOTE

Permanent monitoring of coolant temperature is necessary.

ATTENTION

Obey the manufacturers instructions!

Description	Mixing ratio	
	Concentrate	Water
Conventional coolant	50 %	50 %
Some conventional coolant is available pre-mixed by the manufacturer. In this case do not mix with water, instead follow the manufacturers instructions.		

Boiling point

Conventional coolant:

Conventional coolant with the rate of 50 % water cannot boil at a temperature below 120 °C (248 °F) at a pressure of 1.2 bar (18 psi). The max. coolant temperature limit is therefore 120 °C (248 °F).

NOTE

Permanent monitoring of coolant temperature is necessary.

Waterless coolant (cylinder head – new configuration)

ATTENTION

Waterless coolant is not authorized for ROTAX 912 Series with cylinder head – new configuration.

NOTE

Further all engines which have been equipped with new cylinder heads as spare part or during engine repair/general overhaul since March 1st, 2013 are also affected.

BRP-Rotax INSTALLATION MANUAL

CHECKING THE EFFICIENCY OF THE COOLING SYSTEM

The maximum coolant temperature must be determined in order to check the efficiency of the cooling system.

Suffix -01

Measurement of coolant temperature

There are two temperature sensors on the cylinder 2 and 3 for measuring the coolant temperature. During flight test the place with the highest coolant temperature must be found, this can vary with different engine installation (cowling or free installation, tractor or pusher, flight speed etc.)

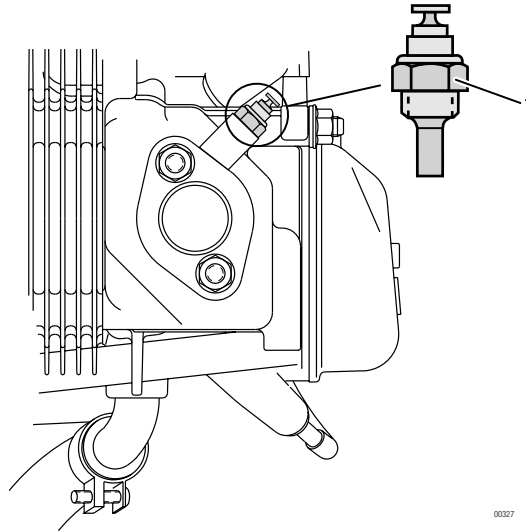

Figure 8.4: Coolant temperature sensor

1 Coolant temperature sensor

NOTE

At engines with cylinder heads of the new configuration, the cooling system must be designed so that the operating limits are not exceeded. A determination of the dependency on coolant temperature and cylinder head temperature is not necessary any more.

without Suffix -01

Cylinder head temperature

There are two temperature sensors (1) on the cylinder 2 and 3 for measuring the cylinder head temperature. During flight test the place with the highest cylinder head temperature must be found, this can vary with different engine installation (cowling or free installation, tractor or pusher, etc.).

BRP-Rotax INSTALLATION MANUAL

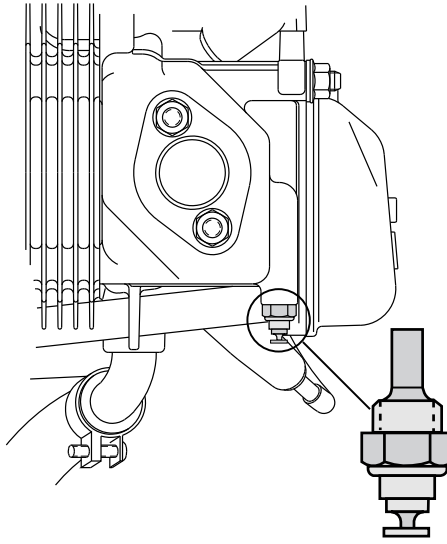

Figure 8.5: Cylinder head temperature sensor (without Suffix -01)

Coolant outlet temperature

⚠ WARNING

Non-compliance can result in serious injuries or death!
Do not restrict the coolant flow with the sensor.

ATTENTION

It is possible to record a false measurement when measuring fluid temperatures.
If fluid volume is lost and the sensor is not fully submerged in the liquid, the indicating instrument could incorrectly display a lower temperature, by measuring the air temperature instead of the coolant temperature.

The measuring of the coolant exit temperature is performed using a separate sensor, which has to be installed in the line between expansion tank and radiator inlet.

BRP-Rotax INSTALLATION MANUAL

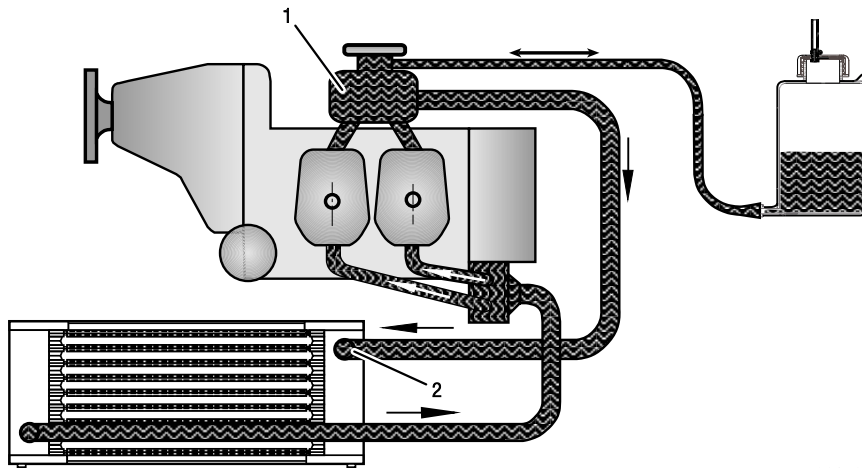

09152

Figure 8.6: Measuring of the coolant exit temperature

1 Expansion tank

2 Radiator inlet

Installation

The sensor may be installed in a "TEE" inline with the fluid hose or the expansion tank may be modified to attach the sensor (not supplied by BRP-Rotax).

Cylinder wall temperature

Max. permitted cylinder wall temperature on hottest cylinder is 200 °C (392 °F). See the following figure.

NOTE

If this temperature is exceeded, appropriate measures (e.g. cooling air ducts, modifications to cowling, etc.) must be taken to bring it within limits again.

BRP-Rotax INSTALLATION MANUAL

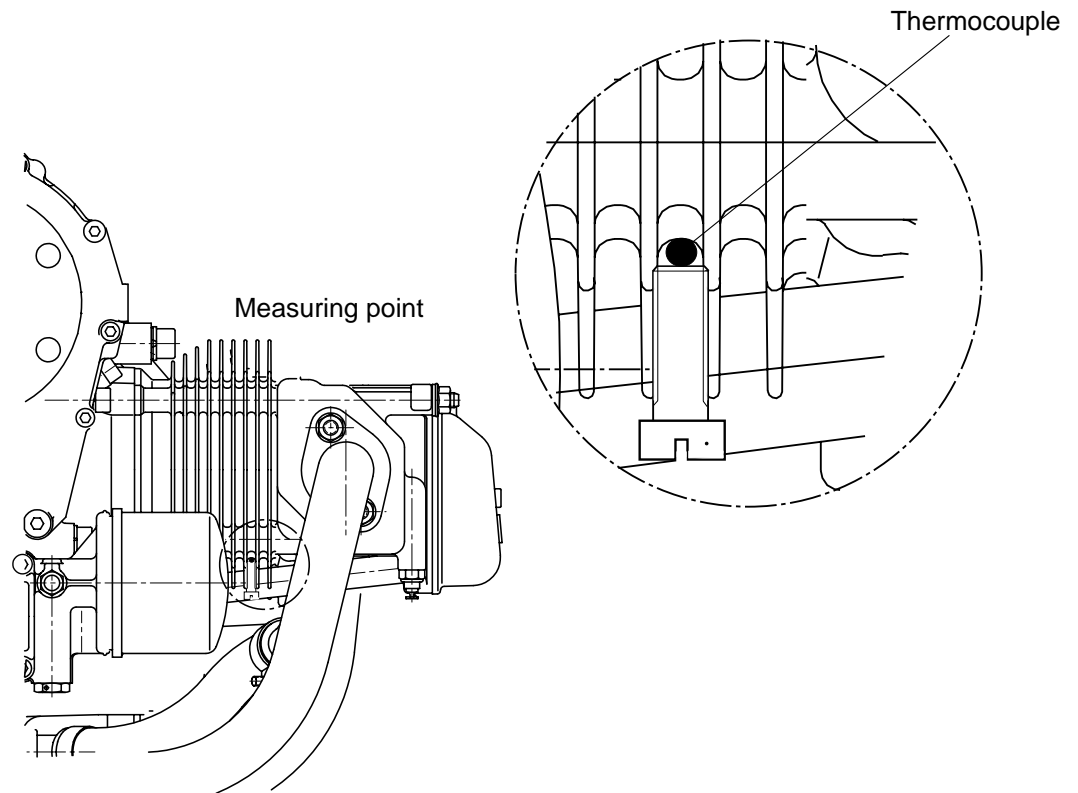

Figure 8.7: Measuring point

Pressure test

To ensure the System has no leakage, remove the pressure cap from the expansion tank. Then attach the pressure tester and pump the system until the pressure manometer shows 1.2 bar (18 psi). After min. 1 minute, there should be still 1.2 bar (18 psi) pressure in the system.

- Check the efficiency of the coolant radiator and its proper sealing between cowling and radiator.
- Check the proper flow between expansion tank and overflow bottle.
- Ensure that no ram air is induced onto the overflow bottle vent line.
- Check efficiency of air duct (if installed) and proper air flow through the duct and around cylinders.
- Consider cold (winter) and hot (summer) conditions in ground and flight testing.
- Check proper dampening of the water radiator and stressless installation and proper sealing.

BRP-Rotax INSTALLATION MANUAL

DETERMINATION OF OPERATING LIMITS, COOLANT AND NECESSARY MODIFICATION ON RADIATOR INSTALLATION FOR ENGINE

Maximum values With Suffix -01: Not relevant.

Maximum values Without Suffix -01.

Depending on the achieved MAX. = maximum values of the cylinder head temperature and the coolant temperature (see latest Operators Manual) following action are necessary:

Conventional coolant		
Coolant temperature	Cylinder head temperature	Action
less than MAX.	less than MAX.	Both values are below operating limit. It is necessary to monitoring constantly cylinder head temperature and coolant exit temperature.
more than MAX.	less than MAX.	Cooling capacity too low. Check of the installation necessary.
less than MAX.	more than MAX.	
more than MAX.	more than MAX.	

Waterless coolant		
Coolant temperature	Cylinder head temperature	Action
less than MAX.	less than MAX.	Maximum cylinder head temperature is below operating limits. Operating with waterless coolant, is permissible without modification to the installation.
more than MAX.	less than MAX.	
less than MAX.	more than MAX.	Cooling capacity too low. Check of the installation necessary.
more than MAX.	more than MAX.	

NOTE

For detection of possible indication error an additional monitoring of the cylinder head temperature is necessary which shows an exceeding in case of coolant loss.

BRP-Rotax INSTALLATION MANUAL

Flight test

The aircraft manufacturer has the option of converting the coolant temperature and the cylinder head temperature to an aircraft specific cylinder head temperature. This is possible by calculating the difference between the head material and the coolant temperature. Refer to the [flight test example](#) that follows.

Once the calculation is made and the indicating instrument re-labelled it is acceptable to use the cylinder head temperature as the primary cockpit display instead of installing a sensor in the coolant flow.

The measurement is based on the maximum coolant temperature and cylinder head temperature (see operating limits of the latest Operators Manual) according to the current requirement.

ATTENTION

In no case a cylinder head temperature higher than the limit (see table of maximum values) can be defined because detonation could not be sufficiently prevented.

Flight test EXAMPLE

Calculated values

(Maximum values found for coolant temperature and cylinder head temperature. Refer to the current specification of the FAA and/or EASA)

Coolant temperature	102 °C (216 °F)
Cylinder head temperature	110 °C (230 °F)
= Difference cylinder head and coolant temperature	8 °C (14 °F)

The cylinder head temperature is 8 °C (14 °F) higher than the coolant temperature.

thus

Coolant temperature limit	120 °C (248 °F)
+ Difference cylinder head and coolant temperature	8 °C (14 °F)
= Total	128 °C (262 °F)

The highest cylinder head temperature permitted in this example is 128 °C (262 °F), so that the max. coolant temperature is kept.

With this special application, safe operation of the engine that prevents boiling of the coolant is possible up to a cylinder head temperature of 128 °C (262 °F).

ATTENTION

This cylinder head temperature with the limit found for this type must be displayed constantly in the cockpit. The indicating instrument and the Manuals must be changed to cylinder head temperature.

ATTENTION

The design of the radiator installation must be changed (example: cowl modifications), if the operating temperature exceeds the specified limits.

BRP-Rotax INSTALLATION MANUAL

COOLANT HOSES

ATTENTION

Hoses exposed to direct heat radiation from the exhaust system, must be suitably protected with heat-resistant protection covers, for example.

Aluminium tubes with an inner diameter of 25 mm (0.98 in) can be used instead of longer hoses. These must have a bulge / bead in order to prevent coolant hoses working loose.

NOTE

Note, the addition of an aluminium tube will double the number of hose clamps required!

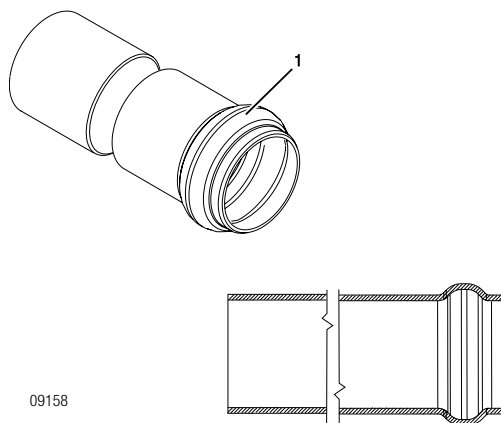

Figure 8.8: Aluminium tube

1 Bulge

Temperature resistance	min. 125 °C (257 °F)
Pressure durability	min. 5 bar (72 psi)
Inner diameter	25 mm (1")
Bending radius	min. 175 mm (6.89 in.) (except moulded hoses)
Material	100 % resistant to glycol, antifreeze, ozone

Hose from expansion tank to the overflow bottle

⚠ WARNING

Non-compliance can result in serious injuries or death!
A soft walled hose is not suitable as it can collapse and cause cooling system failure.

BRP-Rotax INSTALLATION MANUAL

- The hose from the expansion tank to the overflow bottle must be rated for vacuum/suction for min. 125 °C (257 °F), e.g. it must be strong enough to withstand high temperatures and vacuum/suction during the cooling down period.
- The aircraft manufacturer must give the possibility to the pilots to check the coolant level in the expansion tank. Also it is necessary to inform the pilots about the daily inspection of the coolant level in the aircraft manufacturers operators (pilots) manual or an adequate link to the Operators Manual
- It is recommended that adequate measures are taken for carrying out these inspections, e.g. a flap or panel on the cowling or a warning instrument in the cockpit for low coolant level.

CONNECTING SIZE AND POSITION OF CONNECTIONS

The hoses must be fixed with appropriate clips to prevent loss, e.g. with spring type hose clamps, such as those used for the coolant hoses between the water pump and cylinder. Clamps of this type have performed well in the field.

To radiator	Outside diameter	25 mm (1")
	Slip-on length	max. 22 mm (7/8")
To overflow bottle	Outside diameter	8 mm (3/8")
	Slip-on length	max. 15 mm (9/16")
Water inlet elbow	Outside diameter	27 mm (1 1/16")
	Slip-on length	max. 19 mm (3/4")

BRP-Rotax INSTALLATION MANUAL

Connecting dimension

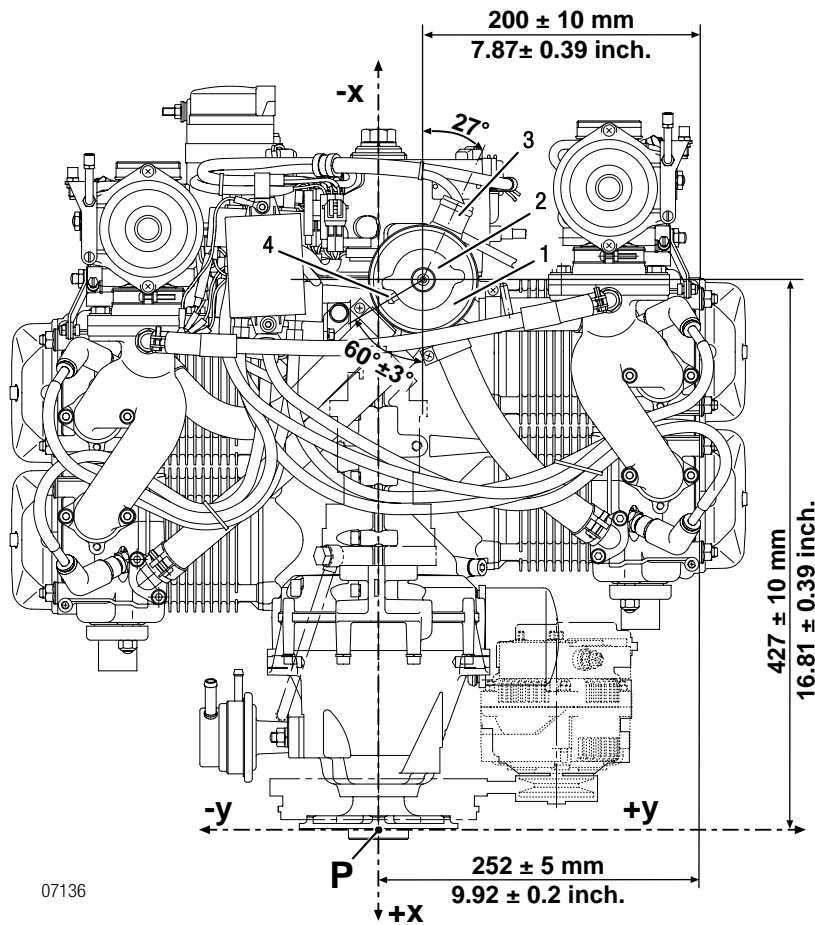

Figure 8.9: Connecting dimension

- | | | | |
|---|----------------------------|---|-----------------------------------|
| 1 | Expansion tank | 2 | Radiator cap |
| 3 | Connection to the radiator | 4 | Connection to the overflow bottle |

Water inlet elbow

ATTENTION

Prevent leakage!

Utilize the full slip-on length for all connections. Secure hoses with suitable clamps or crimp connection.

Choose between six possible installation positions of water inlet elbow appropriate to specific installation (see [Fig. Connecting dimension](#)).

Use two M6x20 Allen screws and lock washers to attach the water inlet elbow. Tighten screws to 10 Nm (90 in lb).

BRP-Rotax INSTALLATION MANUAL

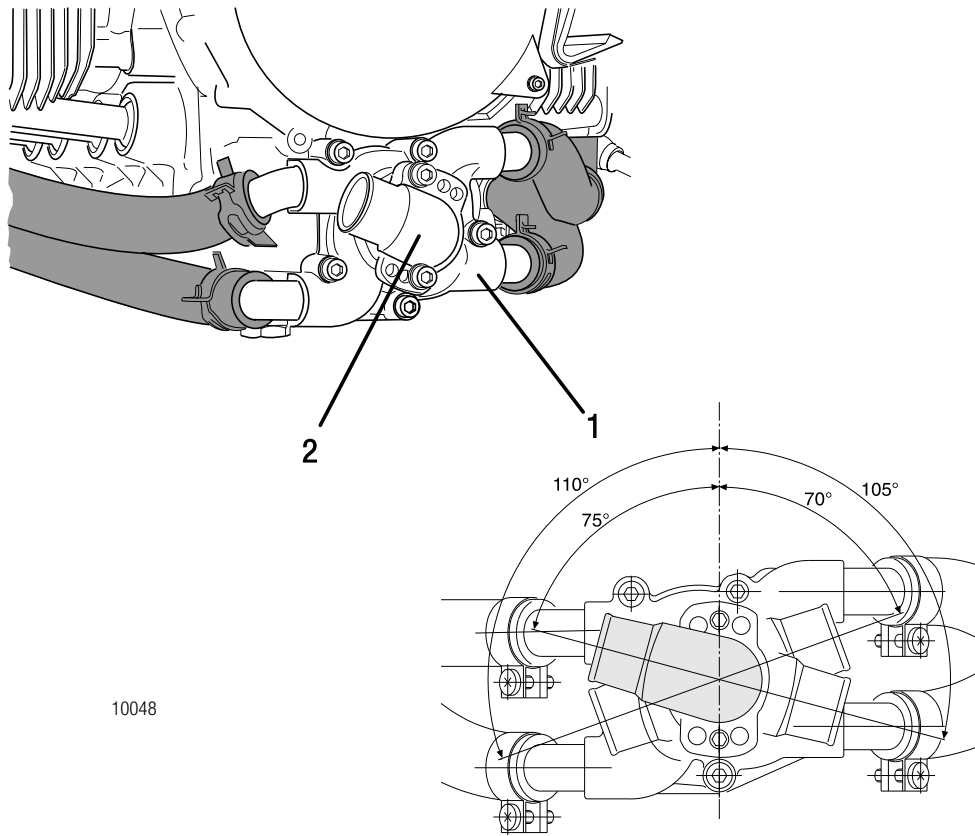

Figure 8.10: Water inlet elbow

1 *Water pump housing*

2 *Water inlet elbow*

BRP-Rotax INSTALLATION MANUAL

REQUIREMENTS, PERMISSIBLE LOCATION AND INSTALLATION POSITION

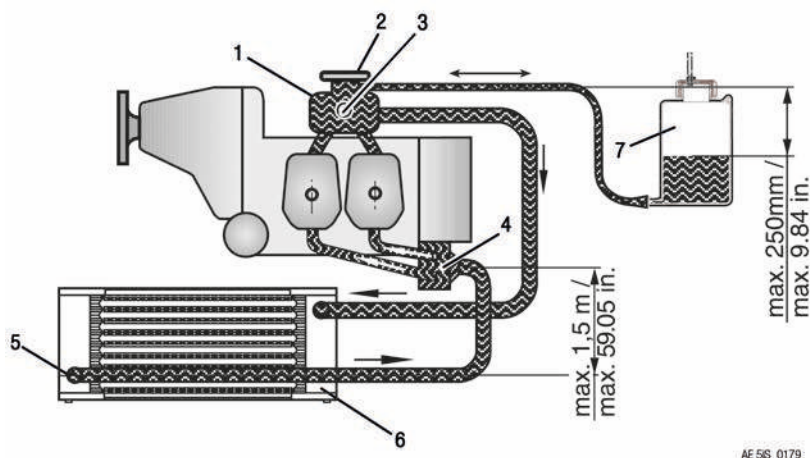

Figure 8.11: Permissible location

- | | | | |
|---|-------------------|---|--------------|
| 1 | Expansion tank | 2 | Pressure cap |
| 3 | Fluid level glass | 4 | Water pump |
| 5 | Radiator outlet | 6 | Radiator |
| 7 | Overflow bottle | | |

Radiator

⚠ WARNING

Non-compliance can result in serious injuries or death!

The components must be designed and installed such that the permissible operating temperatures are maintained and the max. values are not exceeded. This must also apply to "Hot day conditions"!

ATTENTION

If required, the radiator outlet may be located max. 1.5 m (4.92 ft.) underneath the inlet elbow of the water pump and no higher than the expansion tank.

Expansion tank location

To ensure proper operation of the cooling system, the expansion tank with pressure cap in the main operating systems must be installed on the highest point of the cooling circuit.

NOTE

The expansion tank is fitted on top of the engine in standard configuration.

Overflow bottle

The system also needs an overflow bottle in which surplus coolant is collected and returned to the coolant circuit during the cooling down period.

BRP-Rotax INSTALLATION MANUAL

ATTENTION

Ensure proper operation of the cooling system.
The suction height between overflow bottle and expansion tank must not exceed 250 mm (10 in.).

NOTE

For proper operation ensure that the hose to the overflow bottle is as short as possible.

Overflow bottle requirements

See SB-912-039 "Modification of the overflow bottle", latest issue.

- Transparent material
- Temperature resistant from -40 °C to +130 °C (-40 °F to 266 °F)
- 100 % resistant to glycol and suitable for all other antifreeze agents
- Volume approx. 0.5 l (0.13 US gal)
- With vent diameter at least 2.5 mm (0.1 in)
- Label about indicating function and content

Capacity overflow bottle

⚠ WARNING

Non-compliance can result in serious injuries or death!
The overflow bottle must never be empty, otherwise air will be sucked into the cooling circuit; this can have a negative effect on the safe operation of the engine.

Installation overflow bottle

ATTENTION

Emerging coolant can be flammable under certain conditions.
The overflow bottle and its supply and discharge must not be installed close to the exhaust system.

BRP-Rotax
INSTALLATION MANUAL

GENERAL NOTES ON THE COOLING SYSTEM

⚠ WARNING

Non-compliance can result in serious injuries or death!

The furnishing of proof in accordance to the latest FAR and EASA, has to be conducted by the aircraft manufacturer.

Essential parts of the cooling system, such as radiator, etc., are available for this engine from BRP-Rotax.

ATTENTION

Risk of chafing, wear , loss of coolant.

Ensure that no contact with hoses or hose clamps of the engine is given (risk of chafing, wear, loss of coolant) at the installation of external components (governor, vacuum pump).

Radiator

ATTENTION

The size and type of radiator should be adequate to transfer thermal energy of approx. 25 kW (23.7 BTU/s) (for ROTAX 912 A/F/UL) or approx. 28 kW (26.5 BTU/ s) (for ROTAX 912 S/ULS) at take-off power.

In an installation as depicted with the radiator in a higher position than the standard supplied expansion tank, a water accumulator has to be fitted instead of the expansion tank. Additionally a suitable expansion tank has to be installed at the highest point of the cooling circuit.

NOTE

Experience has shown that with good airflow, a radiator with an area of 500 cm² (77.5 in²) is required for trouble free operation.

BRP-Rotax INSTALLATION MANUAL

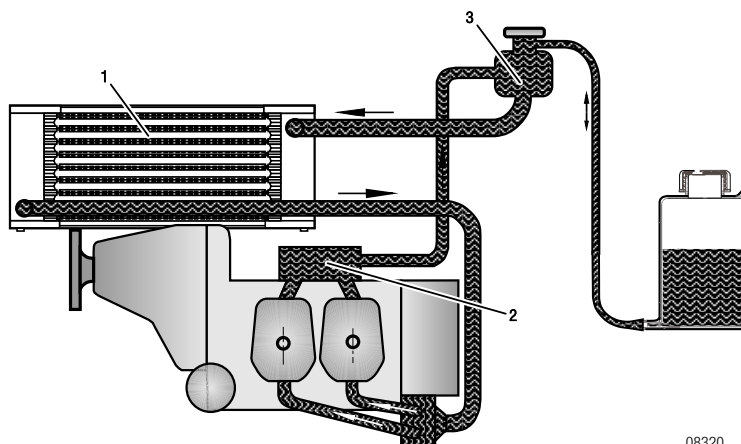

08320

Figure 8.12: Radiator

- | | |
|---|----------------------------|
| <p>1 Radiator</p> <p>3 Expansion tank</p> | <p>2 Water accumulator</p> |
|---|----------------------------|

- Flow rate** The flow rate in the coolant circuit is approx. 60 l/min (15.85 US gal/min.) at 5800 rpm. At full throttle, an approximate value of around 0.75 m³/s (28.59 cu.ft/sec) can be assumed for the required cooling air flow.
- Flow resistance** The flow resistance of the coolant in the optional ROTAX® radiator is correctly adjusted for the cooling system. If using other radiators, check the flow rate and cooling capacity.
- Installation of the radiator** No provision has been made for attachment of the radiator(s) on the engine (rubber mounts are recommended).

ATTENTION

If a GENUINE ROTAX® radiator is not being installed, ensure sufficient cooling capacity.

The radiator must be installed without distortion or stress and be free of vibrations.

COOLANT CAPACITY

4 cylinder heads	560 cm ³ (0.020 cu.ft) (without Suffix -01)
	400 cm ³ (0.016 cu.ft) (with Suffix -01)
Coolant pump	100 cm ³ (0.004 cu.ft)
Expansion tank	250 cm ³ (0.009 cu.ft)
Overflow bottle	approx. 0.5 l (0.13 US gal)
2 m coolant hose (InnerØ 18 mm)	500 cm ³ (0.018 cu.ft)
Total coolant quantity for engine	approx. 1.5 l (0.4 US gal)

BRP-Rotax
INSTALLATION MANUAL

MECHANICAL INTERFACES

Coolant radiator

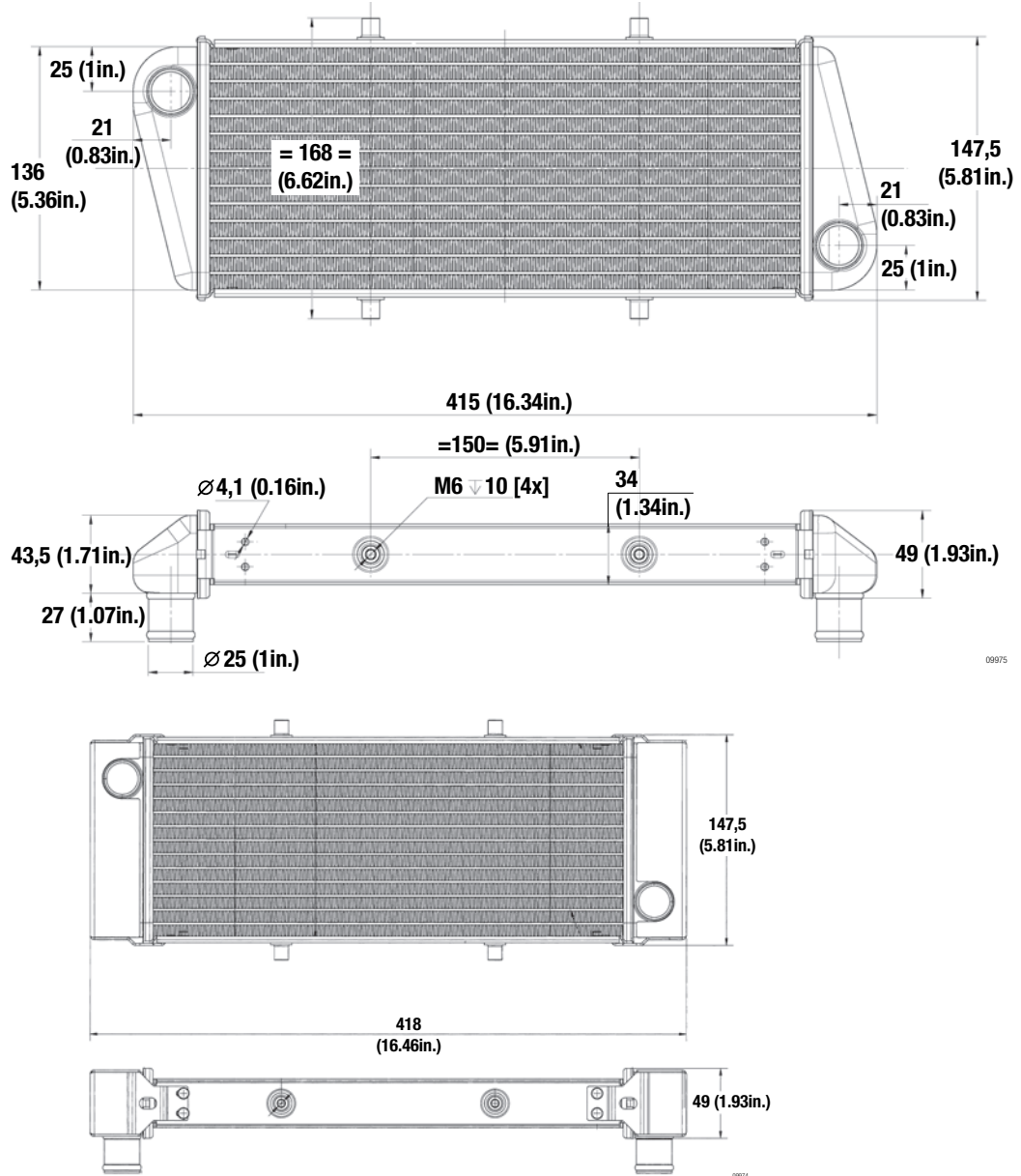

Figure 8.13: Coolant radiator: Connection and dimensions

To attach the coolant radiator within the airframe design four suitable fixation points are available and M6 screws must be used.

BRP-Rotax
INSTALLATION MANUAL

ATTENTION

Make sure proper dampening of the 4 fixation points and assure stress free installation on these 4 fixation points.

BRP-Rotax

INSTALLATION MANUAL

OVERFLOW BOTTLE FROM ROTAX® (OPTIONAL AVAILABLE)

Retrofitting

If the optional ROTAX® overflow bottle is used, the hose from the expansion tank to the overflow bottle system must be provided by manufacturer (OEM).

To vent coolant steam from the overflow bottle in case of overheating, the plastic cap can be retrofitted with a hose nipple and hose.

The hose from the expansion tank must be routed so that coolant cannot come in contact with the hot exhaust system.

The vent hose must be routed in a continuous decline or furnished with a drain bore at its lowest point to drain any condensation.

The vent hose must be protected from any kind of ice formation from condensation, e.g.

- insulation protection or
- routing in a hose with hot air flow and
- furnishing the line with a bypass opening before the cowling outlet.

Attaching hose nipple

1. Unscrew the cap from the overflow bottle.
2. Bore out the existing vent hole.
From dia. 2.5 mm (0.10 in) to dia. 6 mm (0.236 in).
3. Apply LOCTITE 603 to the threads of the hose nipple.
4. Insert hose nipple with the thread first into the vent hole.
5. Fix M6 hex. nut onto the hose nipple.
Tightening torque 5 Nm (3.69 lbft).
6. Screw the cap onto the overflow bottle.

BRP-Rotax INSTALLATION MANUAL

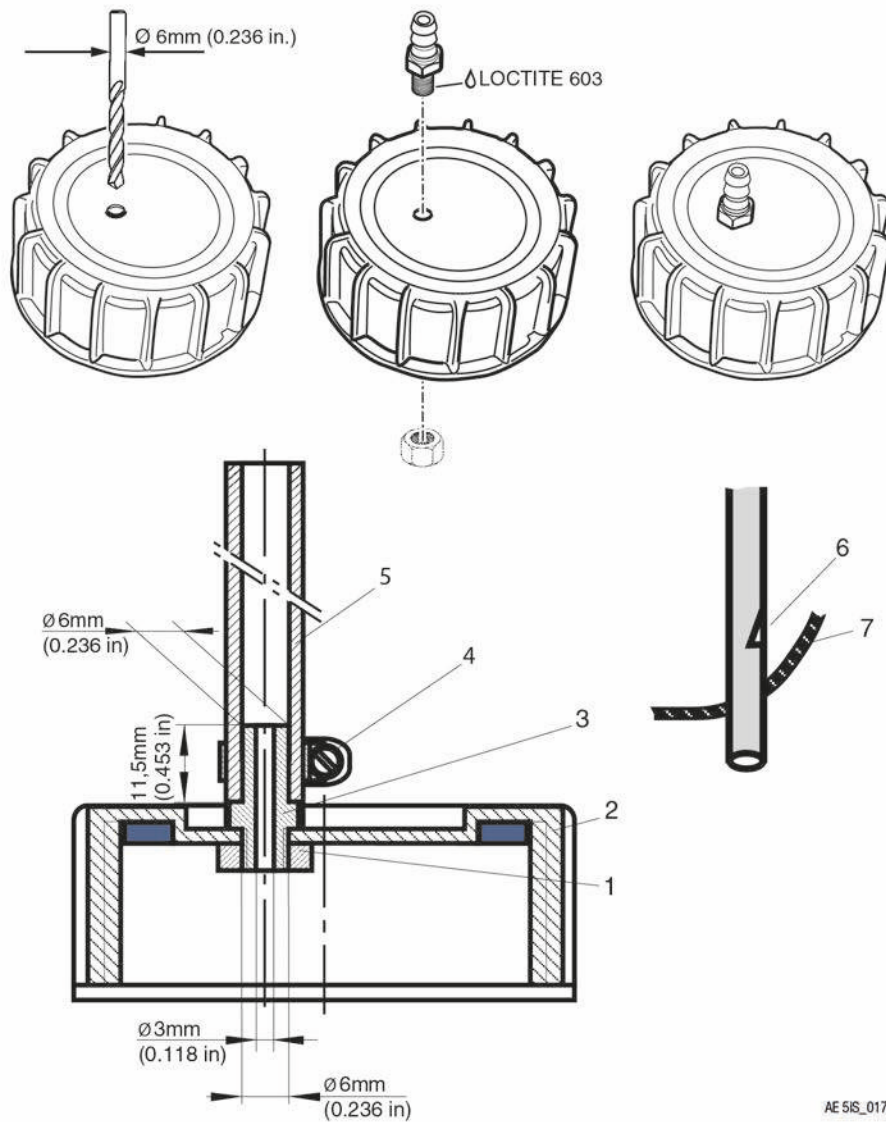

Figure 8.14: Attaching hose nipple

- | | |
|---|--|
| <p>1 M6 hex. nut</p> <p>3 Hose nipple</p> <p>5 Vent hose</p> <p>7 Cowling</p> | <p>2 Cap</p> <p>4 Hose clamp</p> <p>6 Bypass opening</p> |
|---|--|

BRP-Rotax
INSTALLATION MANUAL

AIR COOLING INTERFACES

Position	x-axis	y-axis	z-axis
P1	- 300 mm (- 11.81 in.)	- 30 mm (- 1.18 in.)	- 14 mm (- 0.55 in.)

Attachment points	
Max. permissible force (safe load) in (N) on x, y and z axis	2000 N (449.62 lbf)
Max. permissible bending moment (safe load) in (Nm) in x, y and z axis	50 Nm (36.89 ft. lb)
Min. length of thread (mm)	15 mm (0.59 in.)

NOTE

The stated maximum permissible loads (per screw) are valid only if using the minimum specified thread length, and must never be exceeded. Thread height 18 mm (0.71 in.).

Cooling air duct

For front installation in a closed fuselage, ducting of cooling air to the cylinders is recommended. This removes the need for costly horizontal partitioning (baffles).

NOTE

It also means that the engine remains completely on the warm side of the engine compartment and is very easy to access. In special cases a separate cold air supply to the air filters must be provided. BRP-ROTAX has developed a non-certified cooling air duct especially for this application.

NOTE

In some special cases (entirely closed cowling) a separate cold air supply to the induction air filter should be provided.

Following recommendations should assist the aircraft or fuselage manufacturer in selecting suitable cooling air ducts:

Specification	Description
Cooling capacity	The cooling air duct must be designed so, that it transfers thermal energy of approx. 6 kW (5.7 BTU/s) at take-off performance.
Cross section of air duct	Cross section of the air duct min. 100 cm ² (15.50 in ²).
Material	Glass fibre reinforced plastic or heat and fire resistant material.
Attachment options	Friction-fit on engine block and mounting above the cylinder and the crankcase.

BRP-Rotax
INSTALLATION MANUAL

NOTE

If friction-fit attachment is not sufficient, additional attachment is possible using two M8 threaded lugs on the top of the engine block.

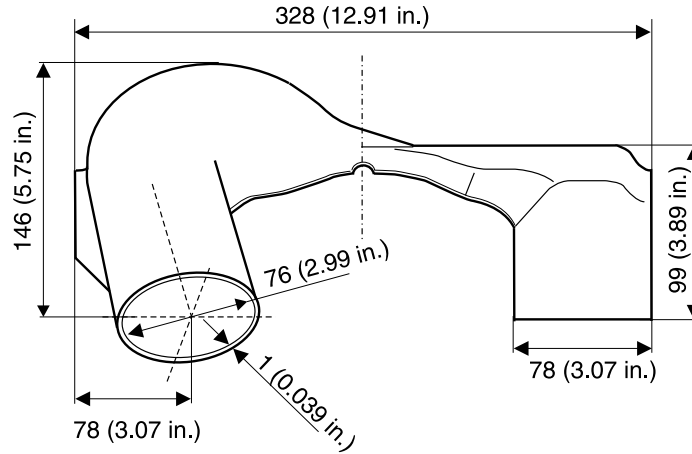

Figure 8.15: Cooling air duct for tractor

BRP-Rotax
INSTALLATION MANUAL

INTENTIONALLY LEFT
BLANK

BRP-Rotax
INSTALLATION MANUAL

Chapter: 76-00-00
ENGINE CONTROLS

TOPICS IN THIS CHAPTER

Mechanical interfaces	2
Sensor for cylinder head temperature	2
Sensor for coolant temperature (Suffix -01)	3
Sensor for oil temperature	5
Oil pressure sensor	7
Mechanical rev counter (tach driver) (optional).....	10
Monitoring of the intake manifold pressure	11
Air temperature in the airbox (optional)	13

BRP-Rotax
INSTALLATION MANUAL

MECHANICAL INTERFACES

ATTENTION

Obey the manufacturers instructions!

These connections to be established in accordance to certification and/or national specifications.

⚠ WARNING

Non-compliance can result in serious injuries or death!

The furnishing of proof in accordance to the latest FAR and EASA, has to be conducted by the aircraft manufacturer.

For notes regarding the electric rev counter consult the [Chapter 24-00-00 section Connection of the electric rev counter](#).

SENSOR FOR CYLINDER HEAD TEMPERATURE

Depending on the cylinder head design (old or new version), there are different methods of measurement with either cylinder head temperature sensor (without Suffix -01) or coolant temperature sensor (Suffix -01).

Graph of sensor resistance over temperature

ATTENTION

The graph resistance over temperature has been determined and is effective at the following conditions only:

Ambient temperature: 20 °C (68 °F)

Tolerance: max. ± 10%

BRP-Rotax INSTALLATION MANUAL

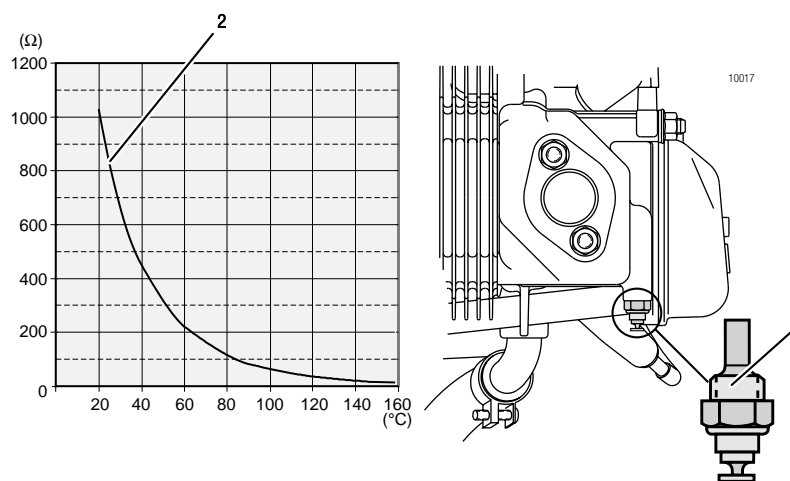

Figure 9.1: Cylinder head temperature (without Suffix -01)

- 1 Sensor for cylinder head temperature 2 Graph resistance over temperature

Technical Data

The temperature sensor is directly fitted into cylinder head i.e. a direct temperature reading of the cylinder head material is taken.

Location In the cylinder head of the cylinder 2 and 3

Connection Spade terminal 6.3 x 0.8 DIN 46247

Grounding Via engine block

Position

Bottom of the cylinder head

	x-axis [mm (in)]	y-axis [mm (in)]	z-axis [mm (in)]
2	-200 (-7.88)	241 (9.49)	-157 (-6.18)
3	-387 (-15.24)	-241 (-9.49)	-157 (-6.18)

SENSOR FOR COOLANT TEMPERATURE (SUFFIX -01)

Depending on the cylinder head design (old or new version), there are different methods of measurement with either cylinder head temperature sensor (without Suffix -01) or coolant temperature sensor (Suffix -01).

Graph of sensor resistance over temperature

BRP-Rotax INSTALLATION MANUAL

ATTENTION

The graph resistance over temperature has been determined and is effective at the following conditions only:

Ambient temperature: 20 °C (68 °F)

Tolerance: max. ± 10%

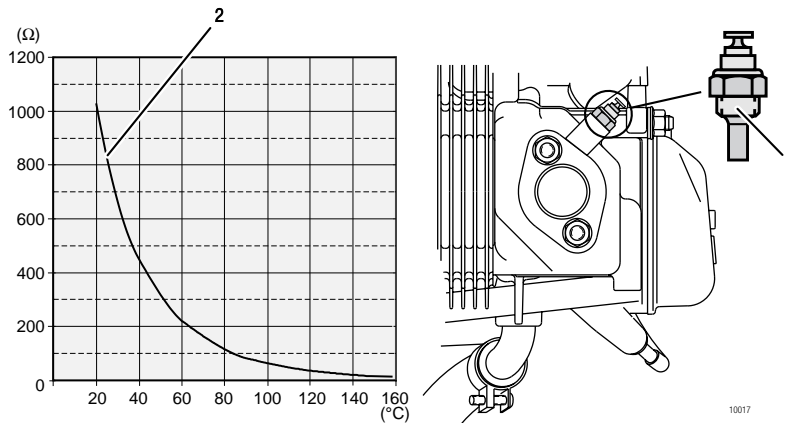

Figure 9.2: Coolant temperature sensor (Suffix -01)

1 Coolant temperature sensor

2 Graph resistance temperature

Technical data

The temperature sensor is directly fitted into cylinder head i.e. a direct temperature reading of the coolant is taken.

Location In the cylinder head of the cylinder 2 and 3

Connection Spade terminal 6.3 x 0.8 DIN 46247

Grounding Via engine block

Position

Top of cylinder head

	x-axis [mm (in)]	y-axis [mm (in)]	z-axis [mm (in)]
2	26.0 (1.02)	225.9 (8.90)	44.4 (1.74)
3	-173.0 (-6.81)	-225.9 (-8.90)	44.4 (1.74)

BRP-Rotax INSTALLATION MANUAL

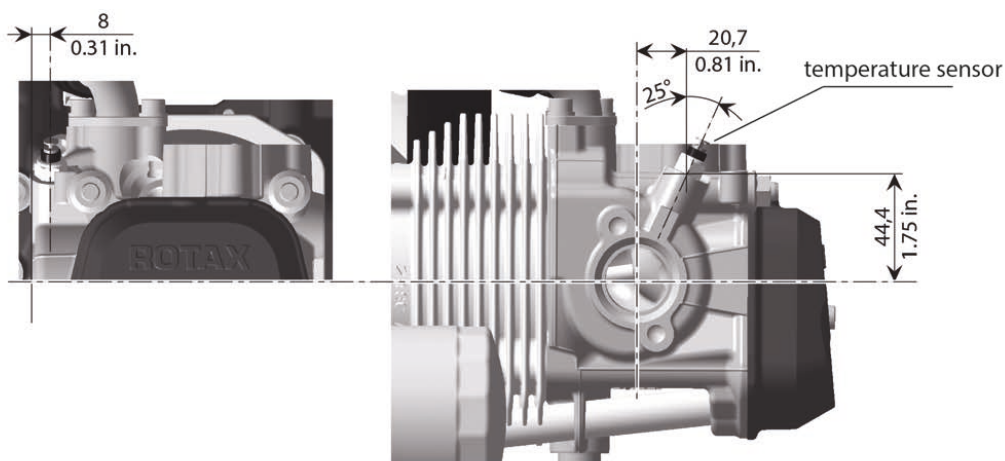

Figure 9.3: Position Temperature sensor

SENSOR FOR OIL TEMPERATURE

⚠ WARNING

Non-compliance can result in serious injuries or death!

The furnishing of proof in accordance to the latest FAR and EASA, has to be conducted by the aircraft manufacturer.

Graph of sensor
resistance over
temperature:

ATTENTION

The graph resistance over temperature has been determined and is effective at the following conditions only:

Ambient temperature: 20 °C (68 °F)

Tolerance: max. ± 10%

BRP-Rotax INSTALLATION MANUAL

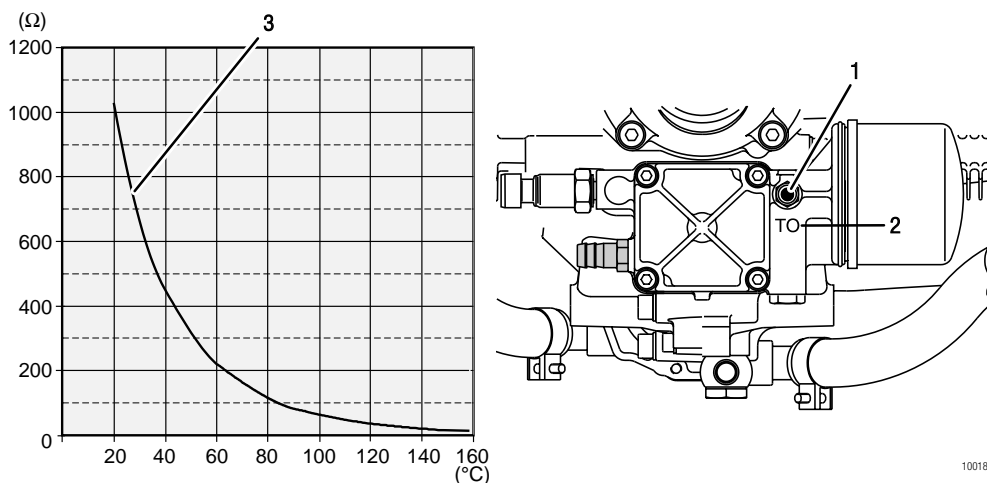

Figure 9.4: Sensor for oil temperature

- 1 Sensor for oil temperature
- 2 TO marking (Temperature Oil)
- 3 Graph resistance over temperature

NOTE

BRP-Rotax offers a non-certified temperature indicating instrument.
Refer to Illustrated Parts Catalog, latest issue.

Marking

Marked with "TO" (Temperature Oil) on oil pump flange.

ATTENTION

To avoid any mix-up with indication wiring, mark this particular cable also with "TO".

Position

	x-axis [mm (in)]	y-axis [mm (in)]	z-axis [mm (in)]
Point of support	-115 (-4.53)	46 (1.81)	-150 (-5.92)

Technical Data

- Location** Oil pump housing
- Connection for sensor wiring** Spade terminal 6.3x0.8 DIN 46247
- Grounding** Via engine block

BRP-Rotax INSTALLATION MANUAL

OIL PRESSURE SENSOR

⚠ WARNING

Non-compliance can result in serious injuries or death!
The furnishing of proof in accordance to the latest FAR and EASA, has to be conducted by the aircraft manufacturer.

NOTE

Due to a configuration of the electric oil pressure sensor (absolute type) are already displayed on the ground approx. 0.2 bar (3 psi) depending on the elevation and ambient pressure).

See also SI-912-030 "Oil pressure sensors for ROTAX® Engine Type 912 and 914 (Series), current issue.

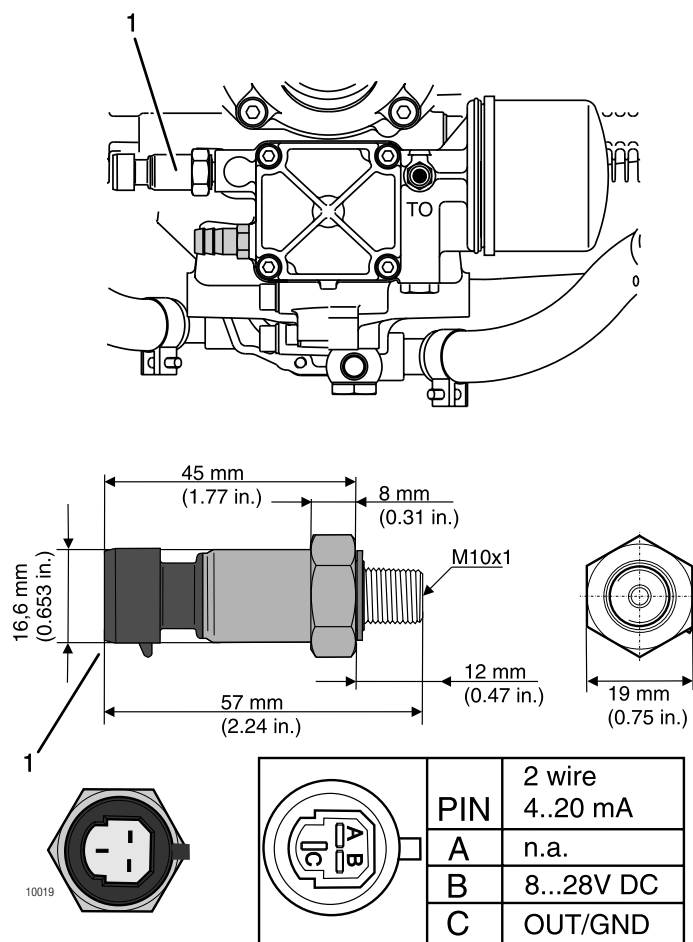

Figure 9.5: Oil pressure sensor

1 Oil pressure sensor

BRP-Rotax

INSTALLATION MANUAL

Technical Data

Location	Oil pump housing
Wire gauge	Standard wire 0.5 mm ² (AWG 20)
Cable length	3 m (118 in.)
Operating temperature range	min. -40 °C (-40 °F) max. +125 °C (+257 °F)
Grounding	Via engine block/airframe ground
Tightening torque	15 Nm (68 in lb) and LOCTITE 243

Output signal

In contrary to the oil pressure sensor offered up to now, which was providing the signal on the basis of a sensor resistance variation, the new oil pressure sensor operates on basis of a current variation. This has to be taken into account for the selection of the appropriate cockpit instrument.

As the instruments need a separate power supply and a different design for the electrical oil pressure sensor, the resistance type instrument (type VDO), which was supplied by BRP-Rotax up to now, is not suitable anymore. Suitable instruments are offered by various instrument manufacturers (e.g. ROAD or Aviasport).

Wiring connections for instrument

The oil pressure sensor is equipped with a connector. As output signal the 2-wire version (4 to 20 mA) is available.

- **Oil pressure sensor PIN A** (connector housing PIN 1) is not connected and has no function.
- **Oil pressure sensor PIN B** (connector housing PIN 2) has to be connected to the positive bus via a fuse or circuit breaker (the Red lead from the current oil pressure sensor).
- **Oil pressure sensor PIN C** (connector housing PIN 3) has to be connected directly to the indicating instrument.

For connection to the indicating instrument a connector set part no. 881302 or oil pressure sensor wire assy. part no. 864250 is available. The connection cable and connector is attached to the engine .

NOTE

The sensor cable can be modified in its length according to the installation situation, e.g. shortened or extended. For extension an appropriate cable (Ölflex®Heat 260 MC 2x 0.5 mm² (AWG 20) or equivalent) can be used. A resistance cable or similar is not necessary.

NOTE

See also the relevant instructions of the instrument supplier/aircraft manufacturer for correct connection and wiring.

BRP-Rotax INSTALLATION MANUAL

Graph current over pressure

ATTENTION

The graph current over pressure has been determined and is effective at the following conditions only:

Ambient temperature: 20 °C (68 °F)

Tolerance: max. \pm 3%

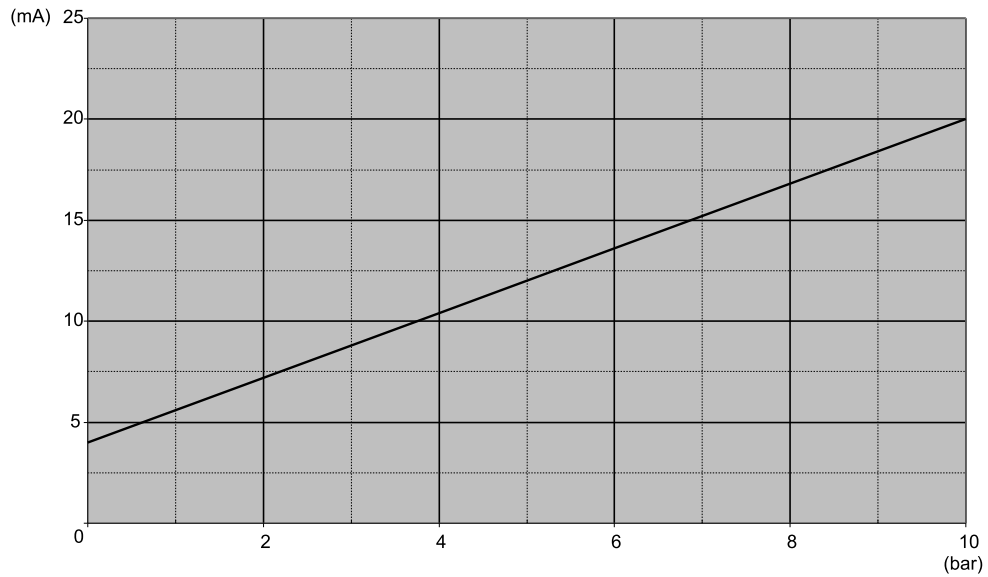

Figure 9.6: Graph current over pressure

BRP-Rotax INSTALLATION MANUAL

MECHANICAL REV COUNTER (TACH DRIVER) (OPTIONAL)

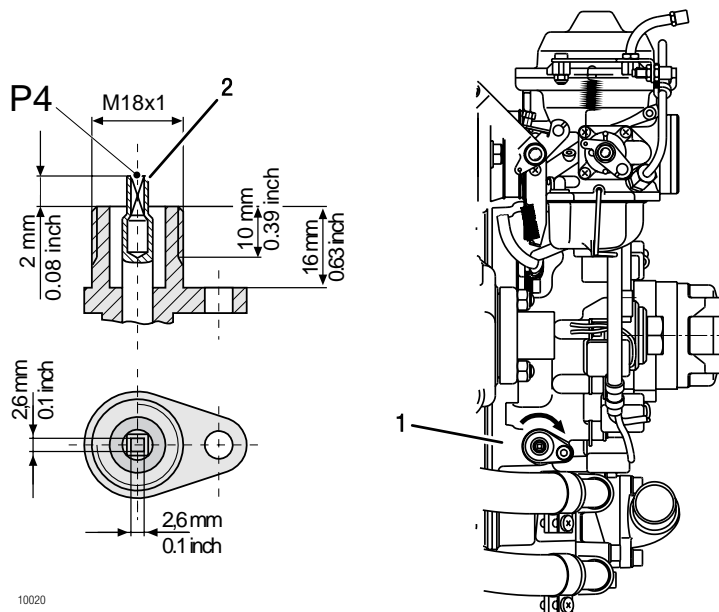

Figure 9.7: Mechanical rev counter

1 Ignition housing

2 Rev counter shaft

Technical Data

Location	Ignition housing
Direction of rotation of the rev counter shaft	Right (Clockwise)
Reduction ratio	i= 4 i.e. 1/4 of engine speed
Installation dimensions	See Figure 9.7: Mechanical rev counter

Position

	x-axis [mm (in)]	y-axis [mm (in)]	z-axis [mm (in)]
Point of engagement P4	-465 (-18.31)	87 (3.43)	-160 (-6.3)

BRP-Rotax
INSTALLATION MANUAL

MONITORING OF THE INTAKE MANIFOLD PRESSURE

ATTENTION

Prevent leakage!

Utilize the full slip-on length for all connections. Secure hoses with suitable clamps or crimp connection.

**Connection
nipple**

Connecting nipple (1) to measure manifold pressure:

Outside diameter: 6 mm (1/4")

Slip-on length: max. 17 mm (11/16")

ATTENTION

Protective coverings are only for use during transport and engine installation.

If connection for pressure reading is not employed it has to be suitably plugged. New style compensating tubes have this connection plugged by a screw M3.5x6.

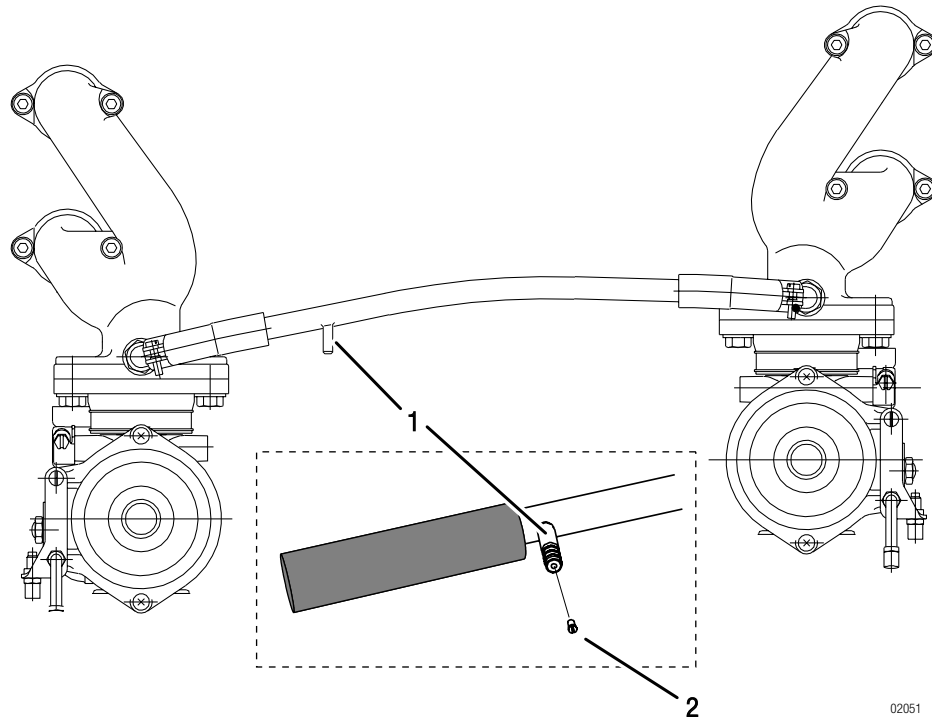

Figure 9.8: Monitoring of the intake manifold pressure

1 Connection nipple

2 Screw M3.5x6

BRP-Rotax
INSTALLATION MANUAL

ATTENTION

Flawless operation of the indicating instrument requires the installations of a water trap between engine and instrument for the fuel condensate.

⚠ WARNING

Non-compliance can result in serious injuries or death!
The furnishing of proof in accordance to the latest FAR and EASA, has to be conducted by the aircraft manufacturer.

BRP-Rotax
INSTALLATION MANUAL

AIR TEMPERATURE IN THE AIRBOX (OPTIONAL)

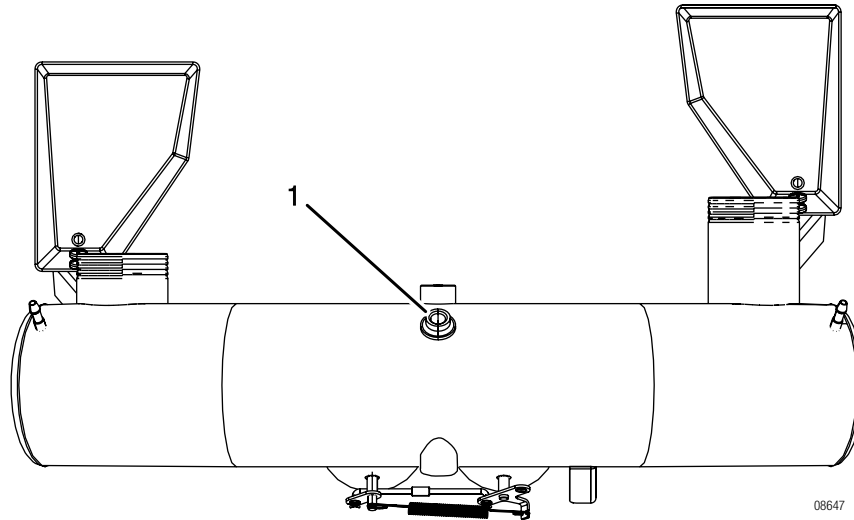

Figure 9.9: Airbox plug screw

1 Plug screw

Plug screw

To take air temperature readings in the airbox a connection is provided. This connection is closed on the standard engine by a plug screw.

Thread: M6

Thread length: ca. 9 mm (3/8")

BRP-Rotax
INSTALLATION MANUAL

INTENTIONALLY LEFT
BLANK

BRP-Rotax
INSTALLATION MANUAL

Chapter: 78-00-00
EXHAUST SYSTEM

TOPICS IN THIS CHAPTER

Interface overview2

General notes on the exhaust system.....3

Select a suitable exhaust system3

System limitations5

Attaching the exhaust system7

Reading of EGT temperature9

Data for optional components of exhaust system 10

BRP-Rotax
INSTALLATION MANUAL

INTERFACE OVERVIEW

⚠ WARNING

RISK OF FIRE! Non-compliance can result in serious injuries or death!
Connect drainage lines well, otherwise emerging fuel from a possible leakage could drip onto the exhaust system.

ATTENTION

The exhaust system must be designed by the aircraft or fuselage manufacturer such that the permissible loads and bending moments on the points of attachment are not exceeded. The exhaust system may require additional support.

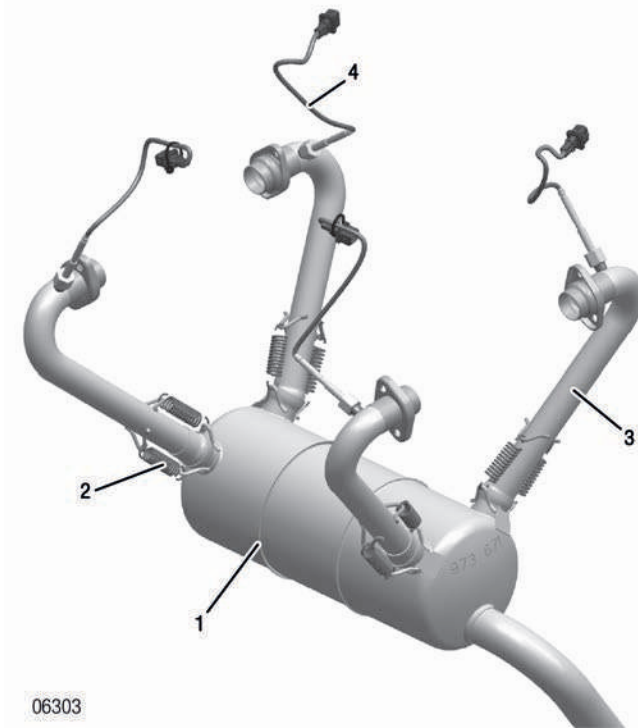

Figure 10.1: Exhaust system, TYPICAL

- | | | | |
|---|--------------|---|----------------------------------|
| 1 | Muffler | 2 | Tension spring |
| 3 | Exhaust tube | 4 | EGT temperature sensor (TYPICAL) |

BRP-Rotax INSTALLATION MANUAL

GENERAL NOTES ON THE EXHAUST SYSTEM

An exhaust system especially designed for universal application has been developed by BRP-Rotax. Certification according to the latest regulations, such as FAR or EASA, must be conducted by the aircraft manufacturer.

⚠ WARNING

Non-compliance can result in serious injuries or death!

The furnishing of proof in accordance to the latest FAR and EASA, has to be conducted by the aircraft manufacturer.

ATTENTION

Damage of the exhaust system possible.

Vibrations due to improper installation and maintenance is the most common reason for damage of the exhaust system.

SELECT A SUITABLE EXHAUST SYSTEM

The following recommendations should help the aircraft or fuselage manufacturer to select a suitable exhaust system.

Damping element The ideal is a common transversal damping element serving all 4 cylinders, positioned under the engine.

NOTE

Equal length of pipes from the cylinder to damping element is recommended for better tuning.

Distribution of the exhaust system Distribution of the exhaust system into 2 separate systems is not recommended. Individual mufflers on either side cause power loss and increased engine noise.

Exhaust flange During assembly, ensure that the flange is parallel to the cylinder head flange and is not protruding.

NOTE

Tighten the exhaust flange evenly and in parallel. There must be a gap of the same size all the way round.

Oil filter There must be a clearance of at least 20 mm (0.79 in.) between the exhaust pipe and the oil filter to allow the oil filter to be fitted and removed without having to slacken off the exhaust system. If a heat shield is fitted, this will also have to be taken into consideration.

ATTENTION

The exhaust system must not adversely affect the operation or replacement of the oil filter.

BRP-Rotax INSTALLATION MANUAL

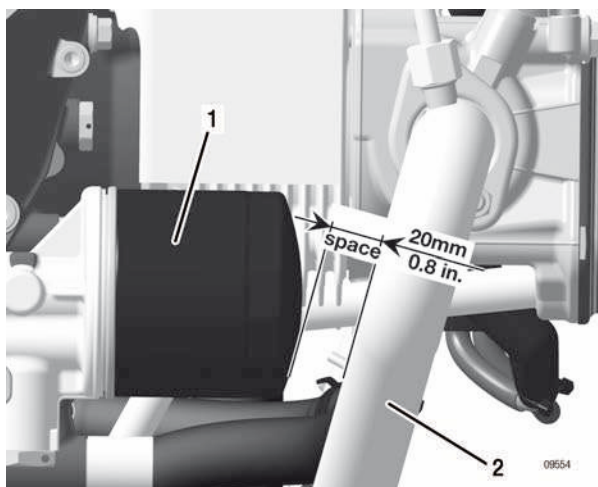

Figure 10.2: Oil filter

1 Oil filter

2 Exhaust manifold

Ball joints

The 4 ball joints must be used to avoid damage due to vibration.

The ball joints should be greased with heat resistant lubricant (ie.: LOCTITE ANTI SEIZE) to avoid jams and locks of the ball joint

Vibration

Springs to be secured with safety wire to prevent FOD!

NOTE

Appropriate to the installation a vibration damping support for the exhaust system has to be provided on the aircraft manufacturers side.

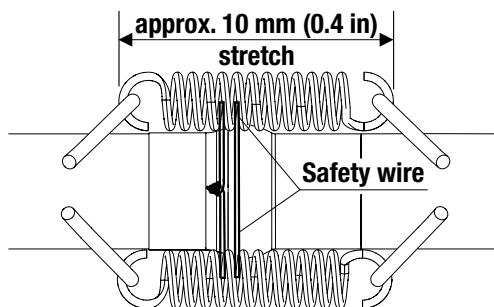

08326

Figure 10.3: Graphic exhaust spring

The sketch illustrates a possibility how to interconnect the exhaust springs to prevent the vibration of these springs and thus premature wear. It is also recommended to apply the high heat silicone for additional damping of vibrations.

BRP-Rotax
INSTALLATION MANUAL

SYSTEM LIMITATIONS

⚠ WARNING

Non-compliance can result in serious injuries or death!

The exhaust system must be designed and built so that the permissible operating temperatures are maintained and the max. exhaust gas temperatures are not exceeded.

ATTENTION

Because of the high temperatures, provide suitable protection against accidental contact.

Install heat shields in required areas (fuel, oil, coolant hoses or tubes) and/or on the electronic components.

ATTENTION

Secure exhaust system by suitable means according to installation requirements (Lockwire, heat-resistant silicone to dampen the exhaust spring etc.).

ATTENTION

The performance specifications relate to ISA (15 °C) (59 °F) conditions and are only achieved if the engine is equipped with an unmodified GENUINE ROTAX exhaust system and airbox.

Operating limits



Refer to latest issue of the Operators Manual .

Technical data

Average radius of exhaust manifold:	at least 40 mm (1.57 in.)
Inner diameter of manifold pipe:	28 mm (1.10 in.)
Damping volume:	approx. 5 l (1.32 US gal)
Back pressure at maximum power:	max. 0.2 bar (2.9 psi) measured in each case approx. 100 mm (3.94 in.) beyond the end of the exhaust flange

If GENUINE ROTAX® exhaust is not in use

The four supplied exhaust sockets with exhaust flange and lock nuts must be used.

Exhaust sockets material:	X6CrNiMoTi 17 12 2 (DIN 1.4571)
Tightening torque of M8 lock nuts:	15 Nm (133 in.lb.)

BRP-Rotax INSTALLATION MANUAL

NOTE

The exhaust flange must not touch the cylinder head.

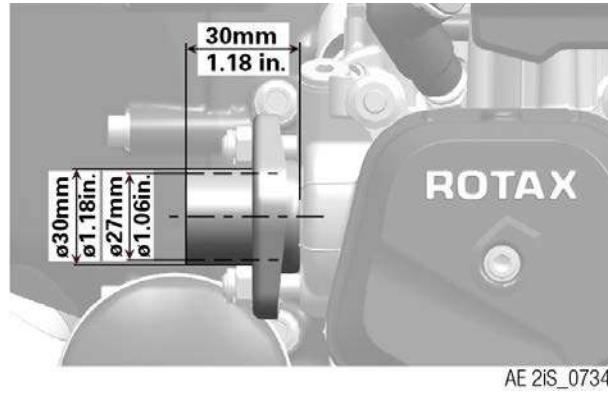

Figure 10.4: Exhaust sockets

BRP-Rotax
INSTALLATION MANUAL

ATTACHING THE EXHAUST SYSTEM

The shape and configuration of the exhaust system is essentially determined by the free space available in the aircraft.

Two M8x23 studs are provided on each cylinder for attaching the exhaust system.

Location of the studs

NOTE

All distances are given in relation to the reference coordinate system (P).

Location	Coordinates		
	x-axis [mm/in]	y-axis[mm/in]	z-axis[mm/in]
Cylinder 1	-160/-6.3	-196/-7.72	-68/-2.68
	-160/-6.3	-212/-8.35	-113/-4.45
Cylinder 2	-192/-7.56	196/7.72	-68/-2.68
	-192/-7.56	212/8.35	-113/-4.45
Cylinder 3	-408/-16.06	-196/-7.72	-68/-2.68
	-408/-16.06	-212/-8.35	-113/-4.45
Cylinder 4	-438/-17.24	196/7.72	-68/-2.68
	-438/-17.24	212/8.35	-113/-4.45

	Attachment points
Max. permissible forces (safe load) in (N/lbforce) on x, y and z axis	1000/224.81
Max. permissible bending moment (safe load) in (Nm/ft.lb) on x, y and z axis	40/30

BRP-Rotax INSTALLATION MANUAL

Graphic

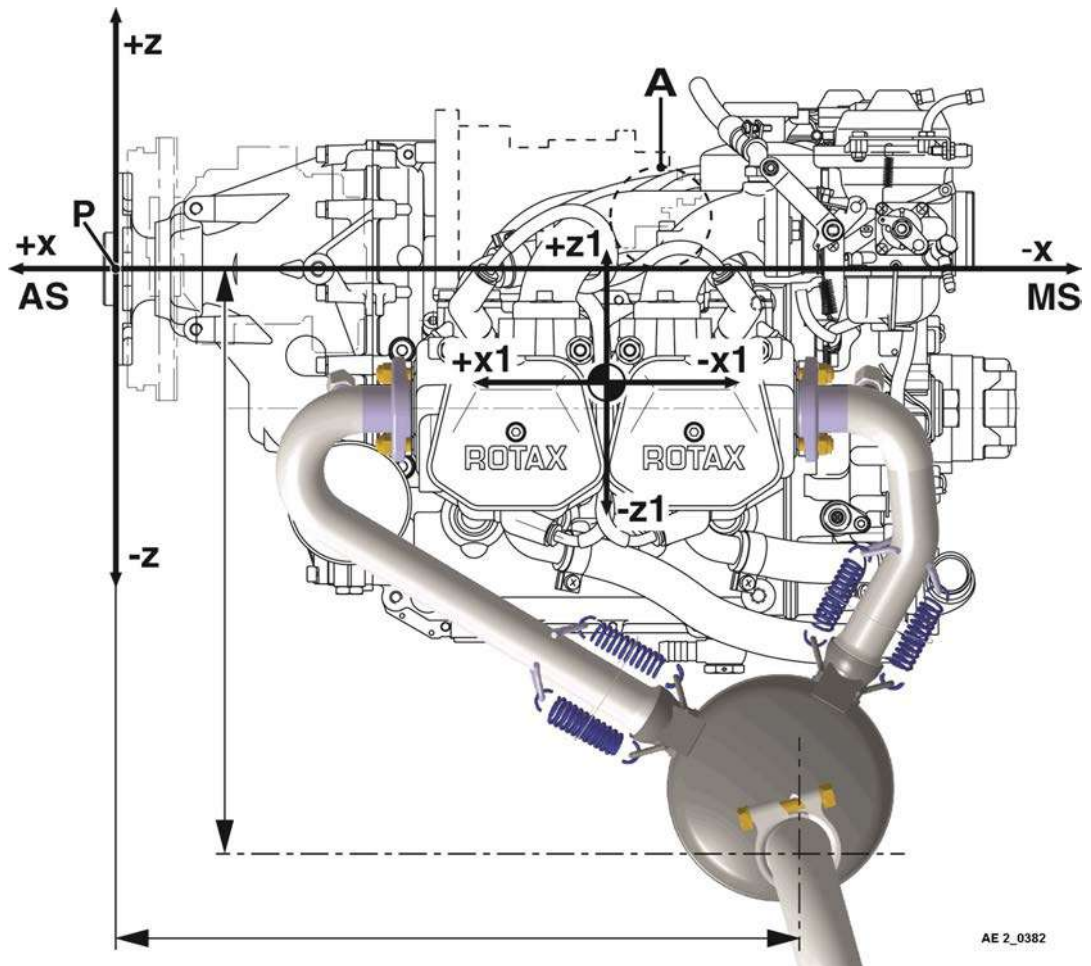

Figure 10.5: Exhaust system assy.

BRP-Rotax
INSTALLATION MANUAL

READING OF EGT TEMPERATURE

Reading

The exhaust gas temperatures (EGT) have to be measured at the initial engine installation in an aircraft and must be verified in the course of test flights.
Readings of EGT taken approx. 100 mm (3.93 in) from exhaust flange connections.

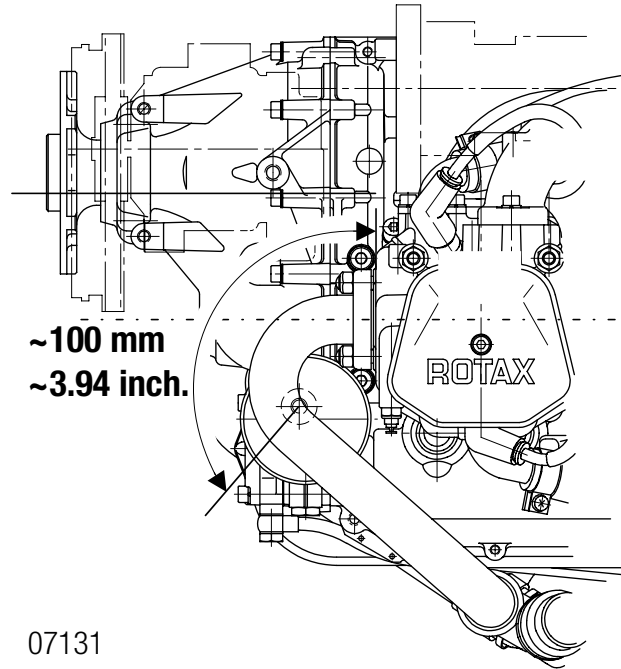

Figure 10.6: Readings of EGT

Operating limit

Exhaust gas temperature (EGT): (both ignition circuits active).
See the current 912 Series Operators Manual.

BRP-Rotax
INSTALLATION MANUAL

DATA FOR OPTIONAL COMPONENTS OF EXHAUST SYSTEM

Weight See [Chapter 72-00-00 section Weight](#).

Exhaust elbow Material: X 15 CrNiSi20-12 (DIN 1.4828) (309 stainless steel)
Material strength: $a = 1.5 \text{ mm}$ (0.06 in.).

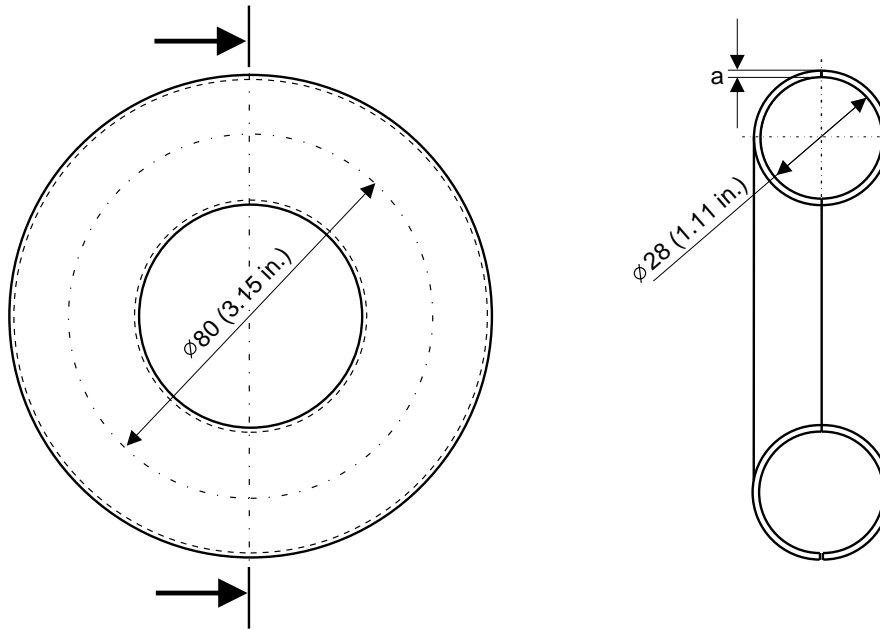

Figure 10.7: Exhaust elbow

BRP-Rotax INSTALLATION MANUAL

Muffler

Material: X 6CrNiTi 189 (DIN 1.4541) (321stainless steel)
Material strength: $a = 1 \text{ mm}$ (0.04 in.)

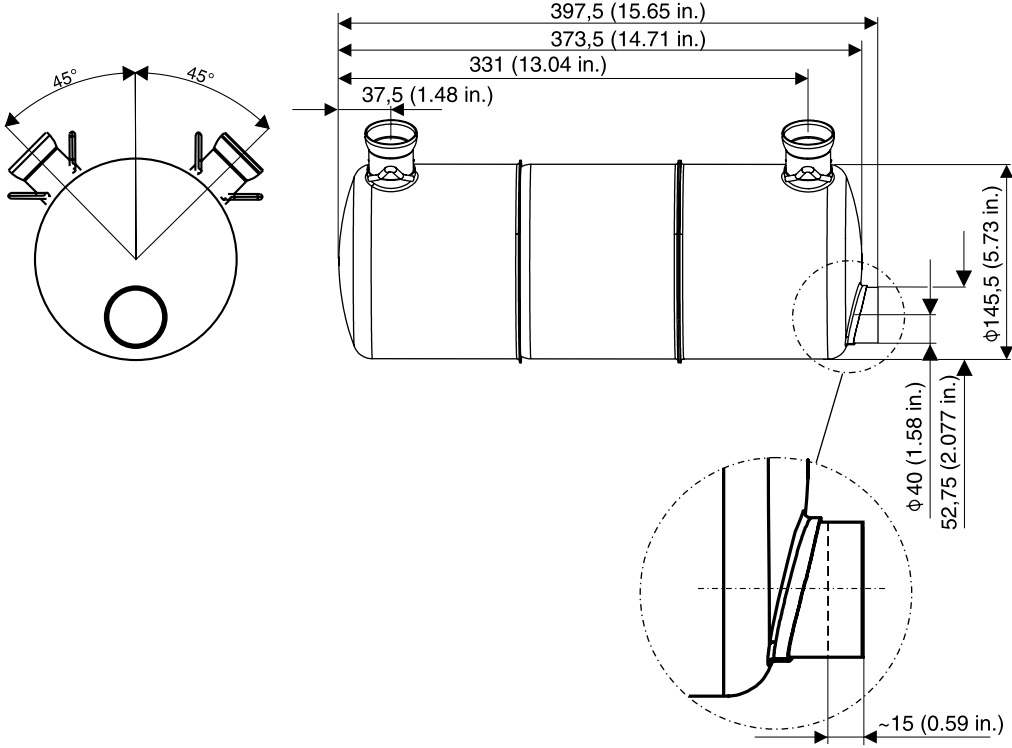

Figure 10.8: Muffler

BRP-Rotax INSTALLATION MANUAL

Tailpipe

Material: X 5CrNi 189 (DIN 1.4301) (304 stainless steel)
Material strength: $a = 1 \text{ mm}$ (0.04 in.)

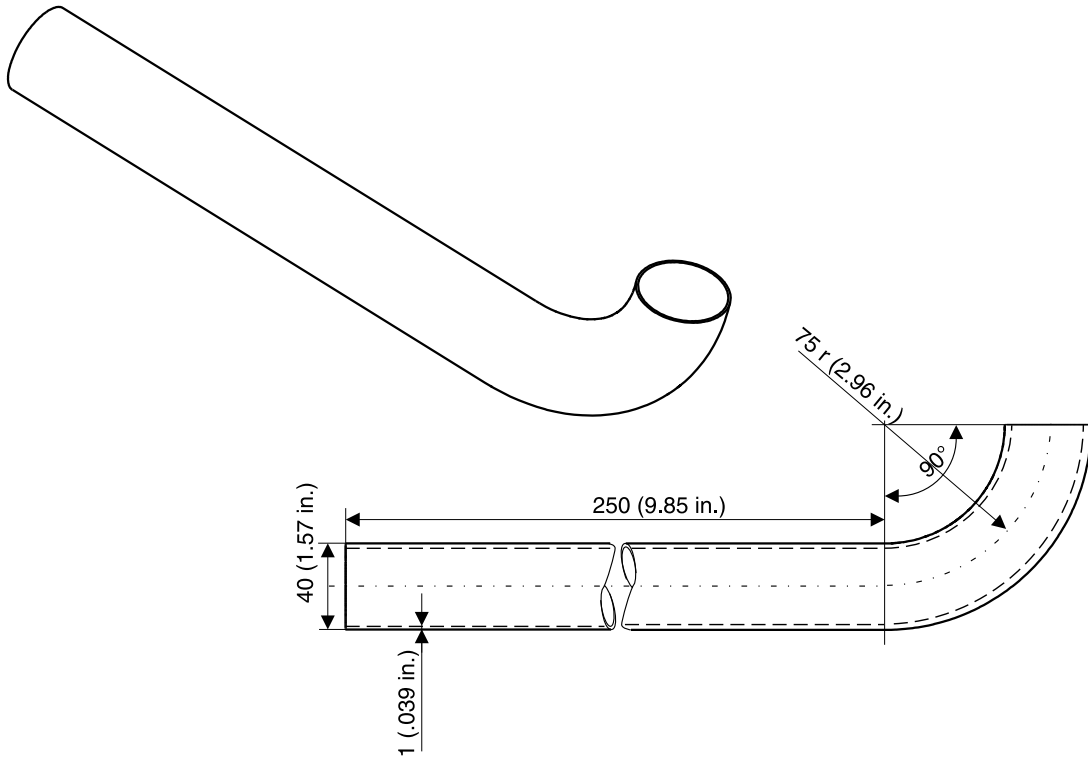

Figure 10.9: Tailpipe

Ball joint (male)

Material: X 15CrNiSi 20, 12 (DIN 1.4301) (304 stainless steel)
Material strength: $a = 1 \text{ mm}$ (0.04 in.)

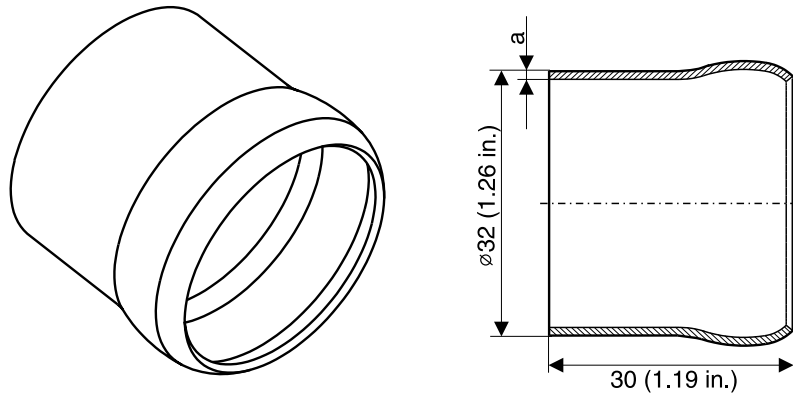

Figure 10.10: Ball joint (male)

BRP-Rotax INSTALLATION MANUAL

Exhaust pipe

Material: X 15CrNiSi 20, 12 (DIN 1.4301) (304 stainless steel)
Material strength: $a = 1 \text{ mm}$ (0.04 in.)

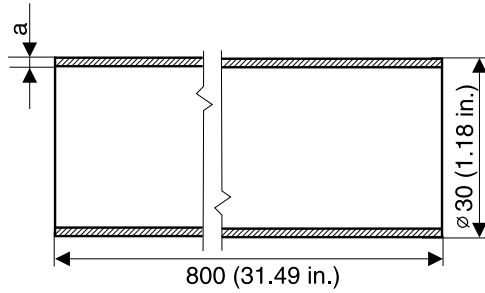
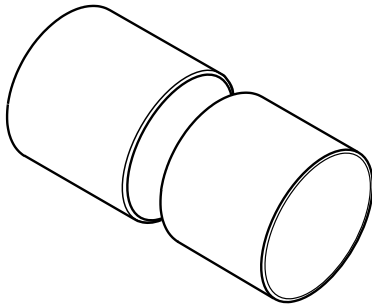

Figure 10.11: Exhaust pipe

BRP-Rotax
INSTALLATION MANUAL

INTENTIONALLY LEFT
BLANK

BRP-Rotax
INSTALLATION MANUAL

Chapter: 79-00-00
LUBRICATION SYSTEM

TOPICS IN THIS CHAPTER

Installation overview	2
System description	3
Limits of operation	5
Low ambient temperature	6
Validation of installation	7
Crankcase pressure measurement	7
Measuring of the vacuum	9
Oil hose requirements	11
Venting line requirements.....	12
Main oil pump (Oil circuit, engine)	13
Oil inlet	13
Oil return.....	15
Oil tank	17
Connections for oil circuit (engine)	19
Permissible position and location	19
Capacity	21
Oil radiator (optional)	22
Permissible position and location	22
Variants of connectors	23
Replenishing and purging of the oil system	24
Checking the hydraulic valve tappet for correct purging	27

BRP-Rotax
INSTALLATION MANUAL

INSTALLATION OVERVIEW

The ROTAX® 912 Series is fitted with a dry sump forced lubrication system with a main oil pump with integrated pressure regulator and oil pressure sensor.

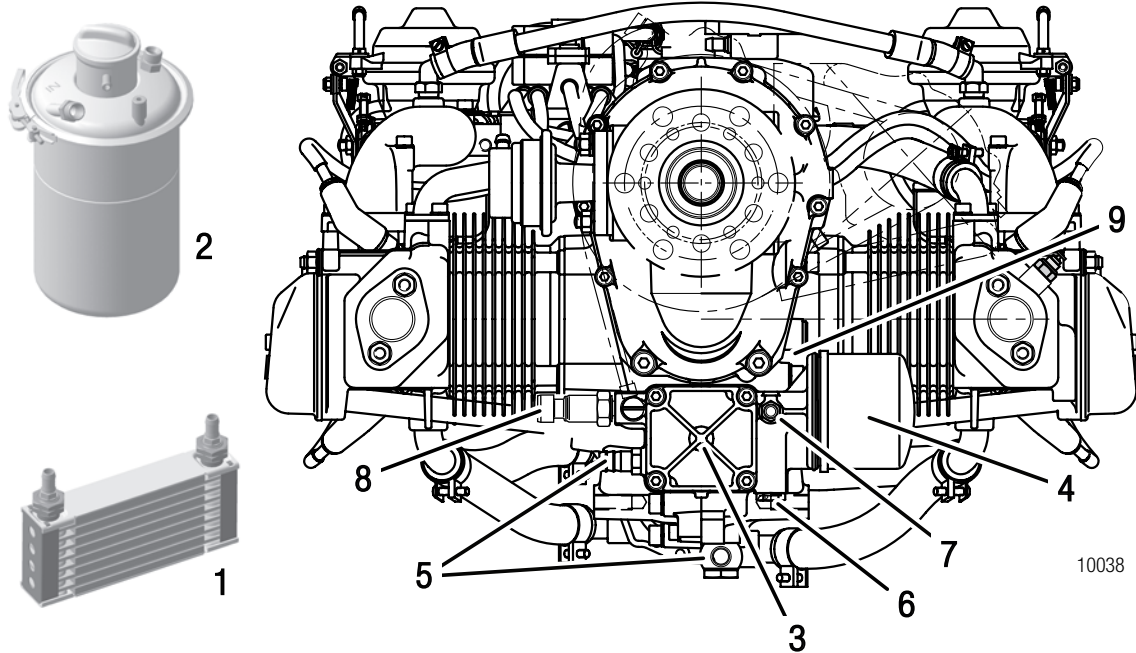

Figure 11.1: Overview

- | | | | |
|---|------------------------|---|---------------------|
| 1 | Oil radiator | 2 | Oil tank |
| 3 | Oil pump | 4 | Oil filter |
| 5 | Oil inlet, Oil outlet | 6 | Plug screw |
| 7 | Oil temperature sensor | 8 | Oil pressure sensor |
| 9 | Magnetic drain plug | | |

BRP-Rotax
INSTALLATION MANUAL

SYSTEM DESCRIPTION

⚠ WARNING

Non-compliance can result in serious injuries or death!
The lubrication system must be designed such that the permissible operating temperatures and maximum values are not exceeded.

NOTE

The oil pumps are driven by the camshaft.

NOTE

The oil circuit is vented to atmosphere via a nipple in the neck of the oil tank.

For the completion of the lubrication system only the following connections need to be established:

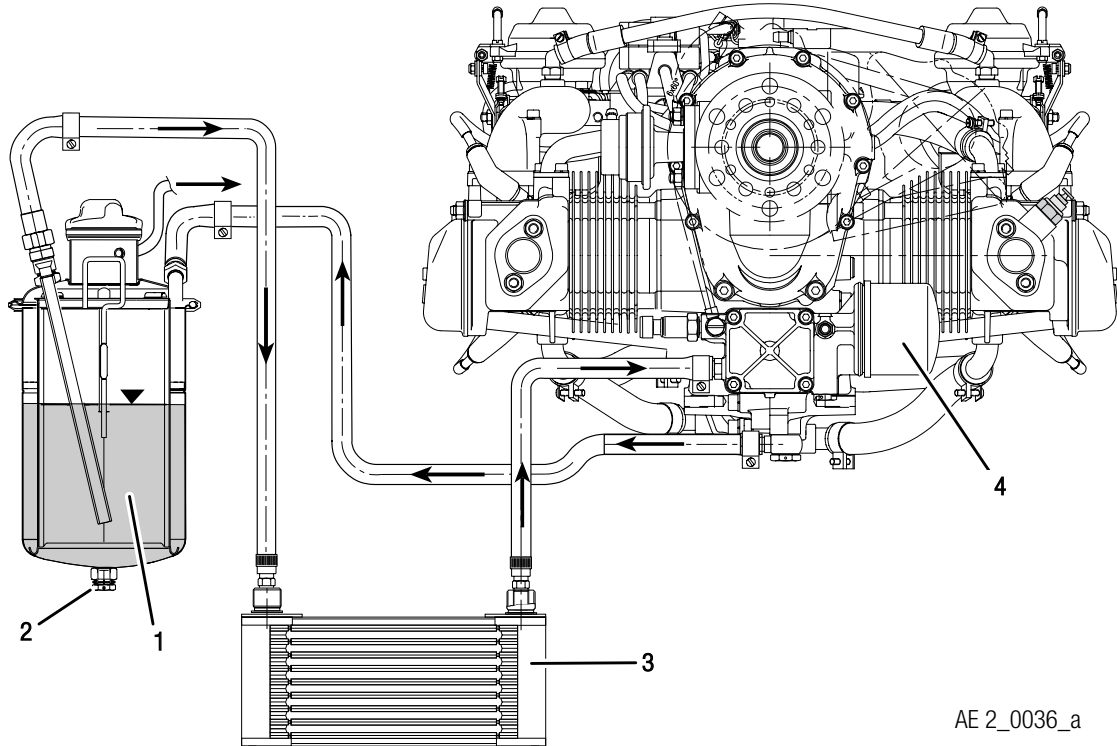

Figure 11.2: Lubrication system

- | | |
|--------------|-------------------|
| 1 Oil tank | 2 Oil drain screw |
| 3 Oil filter | 4 Oil cooler |

BRP-Rotax INSTALLATION MANUAL

Connections

WARNING

Non-compliance can result in serious injuries or death!

The furnishing of proof in accordance to the latest FAR and EASA, has to be conducted by the aircraft manufacturer.

Only the following connections need to be established to complete the lubrication system (oil system).

Oil circuit, engine (main oil pump):

- Oil tank (outlet) to oil cooler
- Oil cooler to oil pump (inlet)
- Oil return to oil tank (inlet)
- Oil tank vent hose to atmosphere

NOTE

An oil tank is included with the standard engine version. No provision has been made for attachment of an oil cooler onto the engine.

BRP-Rotax
INSTALLATION MANUAL

LIMITS OF OPERATION

⚠ WARNING

Non-compliance can result in serious injuries or death!

The lubrication system must be designed such that the permissible operating temperatures and maximum values are not exceeded.

Oil pressure limit See latest Operators Manual, section 2.1 Operating limits.

Oil temperature limit See latest Operators Manual, section 2.1 Operating limits.

BRP-Rotax
INSTALLATION MANUAL

LOW AMBIENT TEMPERATURE

⚠ WARNING

Non-compliance can result in serious injuries or death!

At operation below normal operating temperature, formation of condensate in the oil system might negatively affect oil quality and may lead to corrosion.

Low temperature NOTE

When operating at low temperatures, installation of an oil thermostat, parallel to the oil cooler is recommended.

⚠ WARNING

Non-compliance can result in serious injuries or death!

If an oil thermostat is being used and the ambient temperature is low, there is a possibility that the oil may congeal briefly when in a steep descent flight. Pay extra attention to the oil pressure and oil temperature during these abnormal conditions. If necessary, revert to a cruising or climb situation..

Advantages of oil thermostat:

- safe oil pressure after cold start
- prevention of fuel and water accumulation in the oil



See the Service Letter SL-912-011 "Use of an oil thermostat", current issue.

BRP-Rotax INSTALLATION MANUAL

VALIDATION OF INSTALLATION

General

The validation procedures described in this chapter do not claim to be complete. The correct execution and compliance with all given system limitations and interface descriptions as well as with standards and norms given by authorities must be proven by the aircraft manufacturer.

NOTE

The required pressure gauges and connection parts are not scope of supply.

NOTE

Obey the pressure requirements on interfaces as specified, see crankcase pressure and vacuum measurement.

CRANKCASE PRESSURE MEASUREMENT

Measurement of the mean crankcase pressure at full throttle, this ensures correct oil return from crankcase (blow-by gas).

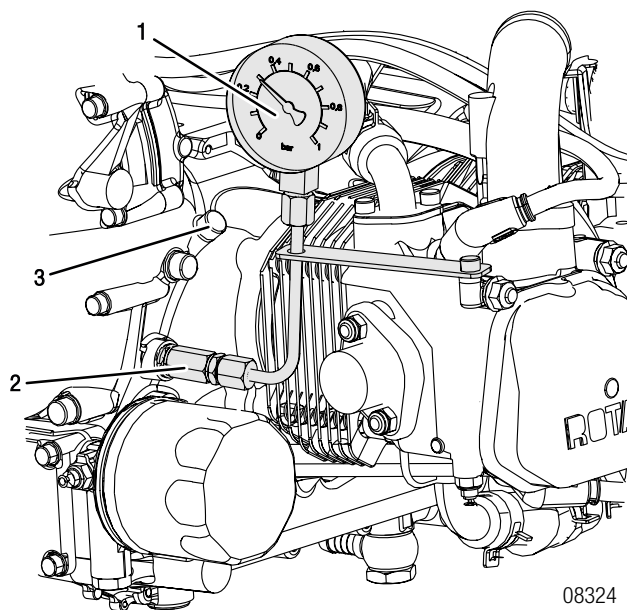

Figure 11.3: Measurement of crankcase pressure

- 1 Pressure indicator
- 2 Magnetic plug (position for adapter)
- 3 Allen screw M8x20 (position for crankshaft locking screw)

ATTENTION

Leakage may occur!

Always use a new sealing ring with Allen screw M8 (position for crankshaft locking screw).

BRP-Rotax

INSTALLATION MANUAL

ATTENTION

Do not remove the magnetic plug for prolonged periods and do not use the measurement equipment during flight operations.

A pressure sensor (pressure gauge with liquid damping) can be fitted instead of the magnetic plug or the crankshaft locking screw. The magnetic plug or the crankshaft locking screw is removed and the pressure sensor is fitted.

Magnetic plug

The thread for the magnetic plug must be M12x1.5 (metric).

Pressure values

The pressure in the crankcase at (full throttle) must not exceed the prevailing ambient pressure by more than 0.6 bar (8.7 psi) at 130 °C (266 °F) oil temperature.

⚠ WARNING

Non-compliance can result in serious injuries or death!

If the readings exceed the pressure limits, then the flow resistance in the oil return line from oil sump to oil tank is too high in the current engine installation (contamination, restrictions of cross-section, etc.). This condition is unsafe and must be rectified immediately.

If crankcase pressure and measuring pressure of the vacuum readings and all operational data (flight attitude, temperatures, etc.) are within the specified limits, then it can be assumed that the oil circuit is working correctly.

BRP-Rotax INSTALLATION MANUAL

MEASURING OF THE VACUUM

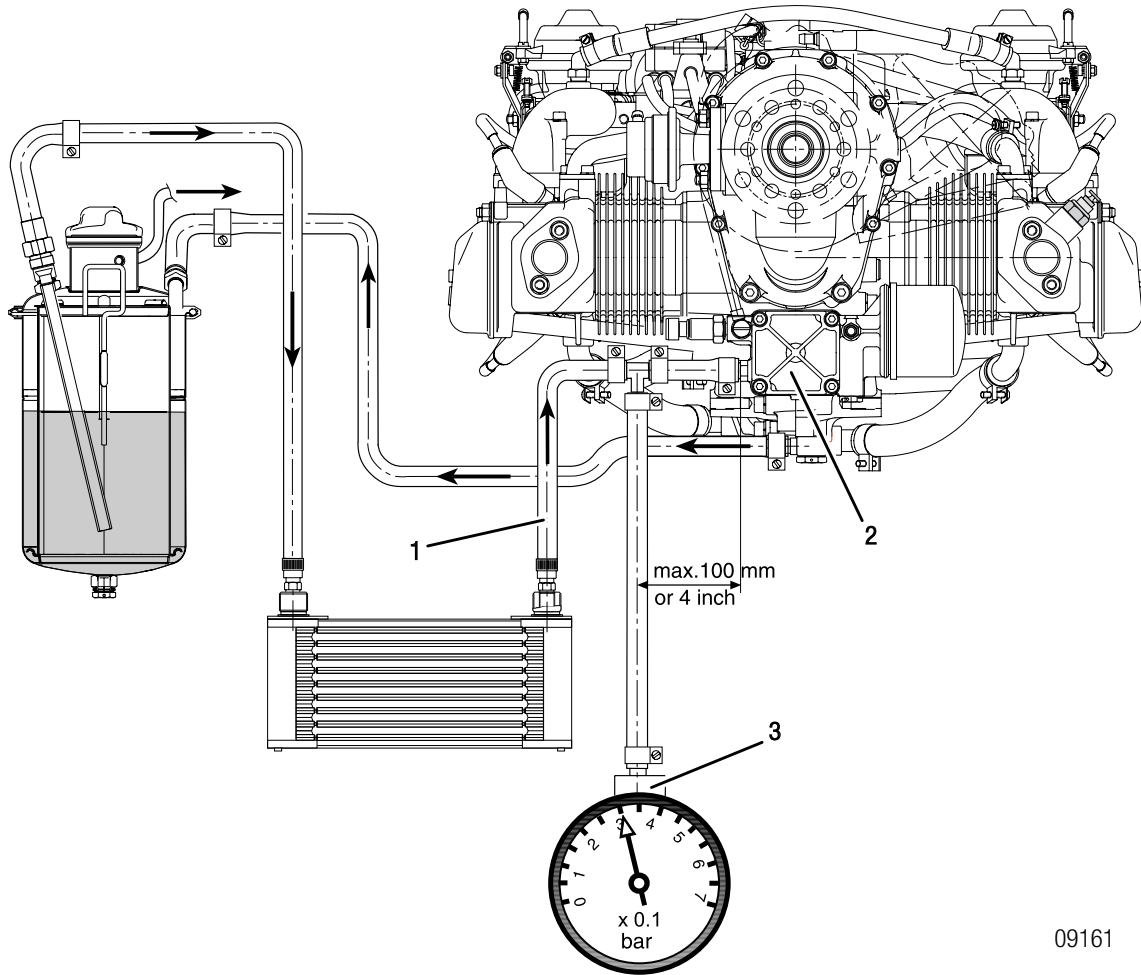

09161

Figure 11.4: Measuring of the vacuum

- 1 Suction oil hose
- 2 Oil pump
- 3 Pressure gauge with liquid damping for vacuum

Measure the vacuum in the suction oil hose- from the oil tank via the oil cooler to the engine oil pump - at a distance of max. 100 mm (4 in.) from the oil pump suction connector.

I Full throttle

At full throttle (take-off rpm) the max. negative pressure must not exceed 0.3 bar (4.35 psi) at 130 °C (266 °F).

BRP-Rotax
INSTALLATION MANUAL

⚠ WARNING

Non-compliance can result in serious injuries or death!

The vacuum must be verified over the complete engine operation range. If the oil is cold, the flow resistance increases, which means that not enough oil will flow on the suction side.

BRP-Rotax
INSTALLATION MANUAL

OIL HOSE REQUIREMENTS

**Main oil pump
(Oil circuit,
engine)**

At negative pressure of -500 mbar (-7.25 psi) and a oil temperature of 150 °C (302 °F) the oil lines must not collapse.

A minimum inner diameter of at least 10 mm (0.39 in.) should be used.

NOTE

Obey the pressure requirements on interfaces as specified, see crankcase pressure and vacuum measurement.

BRP-Rotax INSTALLATION MANUAL

VENTING LINE REQUIREMENTS

Oil tank venting line

Following points should be considered when installing the oil tank venting line:

- Route the line without kinks and avoid sharp bends
- Route the venting line in a continuous decline. Otherwise a drain bore at the lowest point should be foreseen to drain any condensate.

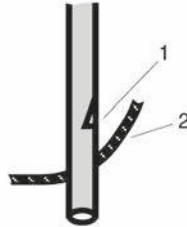

AE 516_0177

Figure 11.5: Bypass opening

1 Bypass opening 2 Cowling

NOTE

Water is a by-product of the combustion of fuel. Most of this water will dissipate from the combustion chamber with the exhaust gases. A small amount will reach the crankcase and must be disposed of through a venting line.

The venting line must be protected from any kind of ice formation for condensation by using e.g. isolation protection or a routing in a hose with hot air flow. Additionally a bypass opening should be foreseen before the cowling outlet.

BRP-Rotax
INSTALLATION MANUAL

MAIN OIL PUMP (OIL CIRCUIT, ENGINE)

ATTENTION

Leakage may occur!

Utilize the full slip-on length for all connections. Secure hoses with suitable screw clamps or crimp connections.

ATTENTION

Possible leakage.

Check that the connections for the oil feed and return lines are correct.

OIL INLET

Depending on engine configuration, the oil feed line connectors may vary.

- 912 A/F/S: Thread M18 or optional UNF-thread (AN-8)
- 912 UL/ULS: Inlet nipple or optional M18 or UNF-thread (AN-8)

Option 1

Thread: M18x1,5x11
Tightening torque of inlet line: 25 Nm (18.5 ft.lb)

NOTE

Suitable for use of a swivel joint.

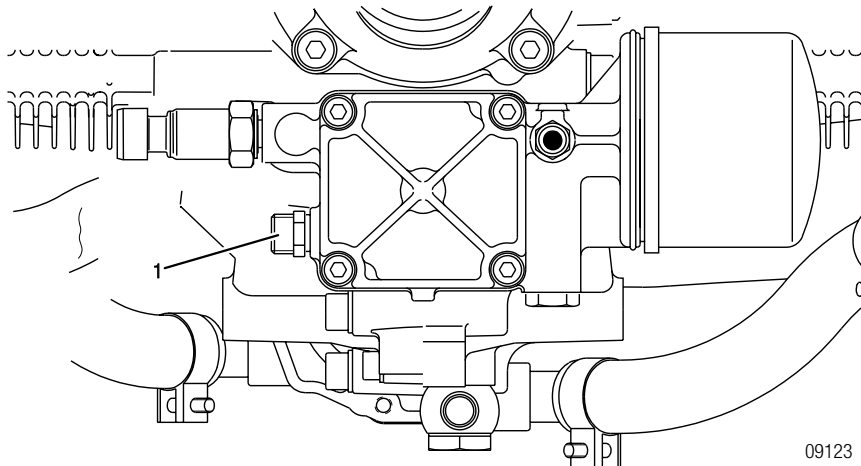

Figure 11.6: Connection, option 1

1 Oil pump (inlet)

BRP-Rotax INSTALLATION MANUAL

Option 2

Inlet nipple outside dia: 13.2 mm (0.52 in)

Slip-on length: max. 21 mm (0.83 in)

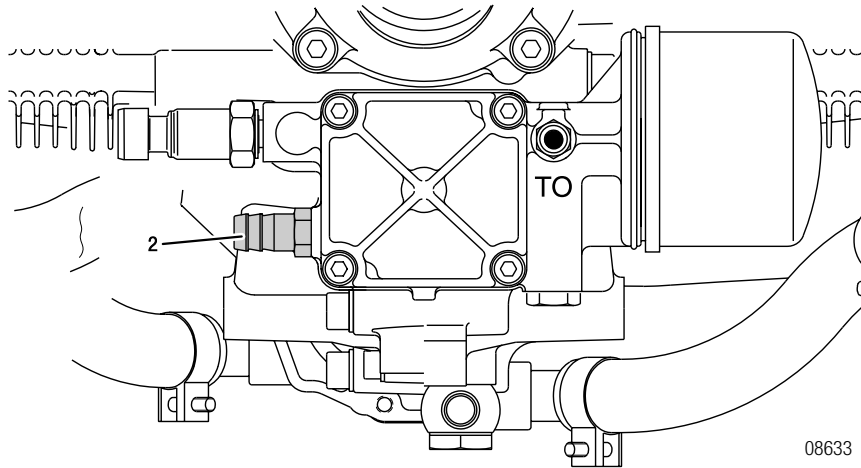

Figure 11.7: Connection, option 2

2 Inlet nipple

Option 3

Thread: 3/4-16 UNF (AN-8)

Tightening torque of inlet line: 25 Nm 25 Nm (18.5 ft.lb)

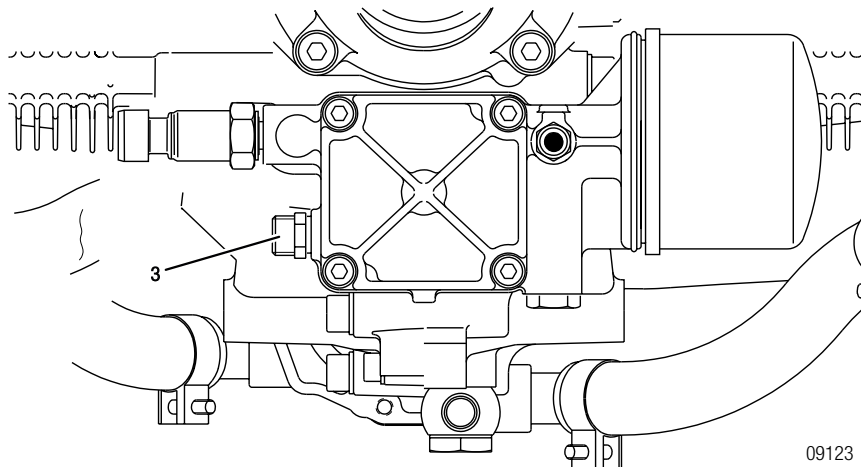

Figure 11.8: Connection, option 3

3 Oil pump (inlet)

BRP-Rotax INSTALLATION MANUAL

OIL RETURN

ATTENTION

The engine design is for a conventional, non-aerobatic, tractor or pusher configuration with the oil return port in the optimum position. Assuming these points are taken into consideration, the engine will be properly lubricated in all normal flight profiles. Aircraft that are not conventional (e.g. airships, gyrocopters, dive brake equipped aircraft, etc.) that require engine load at steep inclination angles may have special lubrication requirements.

Select the appropriate connection for the oil return line according to the propeller configuration and oil system layout.

- Position 1 for tractor configuration.
- Position 2 for pusher configuration.

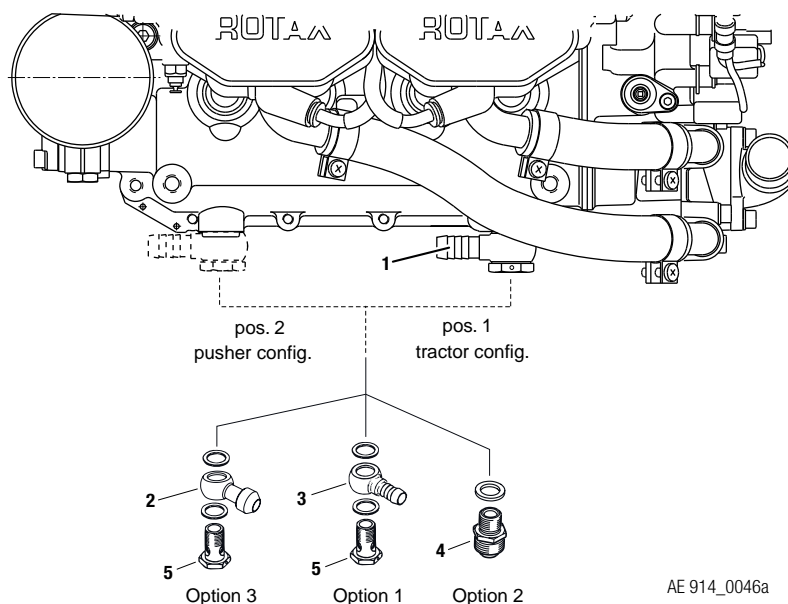

AE 914_0046a

Figure 11.9: Connection oil return, typical

- | | |
|-------------------------|--------------------------------------|
| 1 Slip-on connection | 2 Hose nipple with 3/4-16 UNF (AN-8) |
| 3 Hose nipple 10 | 4 Adapter 3/4-16 UNF (AN-8)/ M16x1,5 |
| 5 Banjo bolt M16x1.5x28 | |

BRP-Rotax INSTALLATION MANUAL

Option 1	with slip-on connection	
	Hose nipple	10 DIN 7642
	Outside diameter	13.5 mm (0.53 in)
	Slip-on length	max. 24 mm (max. 0.94 in)
	Tightening torque of banjo bolt M16x1.5x28	30 Nm (22 ft lb)
Option 2	with adapter	
	Thread	3/4-16 UNF (AN-8)
	Tightening torque of oil return line	25 Nm (18.5 ft lb)
	Tightening torque of screw connection (2) M16x1.5	25 Nm (18.5 ft lb)
Option 3	with hose nipple	
	Thread	3/4-16 UNF (AN-8)
	Hose nipple	10 DIN 7642
	Tightening torque of oil return line	25 Nm (18.5 ft lb)
	Tightening torque of banjo bolt M16x1.5x28	30 Nm (22 ft lb)

BRP-Rotax
INSTALLATION MANUAL

OIL TANK

ATTENTION

Only use the oil tank provided in the scope of delivery, as its design has changed compared with older tanks.

NOTE

Optional extra:

Fitting with either straight or with 90° elbow. Metric M18x1.5 or UNF 3/4-16 thread.

ATTENTION

Check what type of thread or connection is on the supplied oil tank.

ATTENTION

The oil tank cover is also marked with the designations:*IN - oil return line from crankcase*
OUT- outlet to oil cooler/oil pump

BRP-Rotax INSTALLATION MANUAL

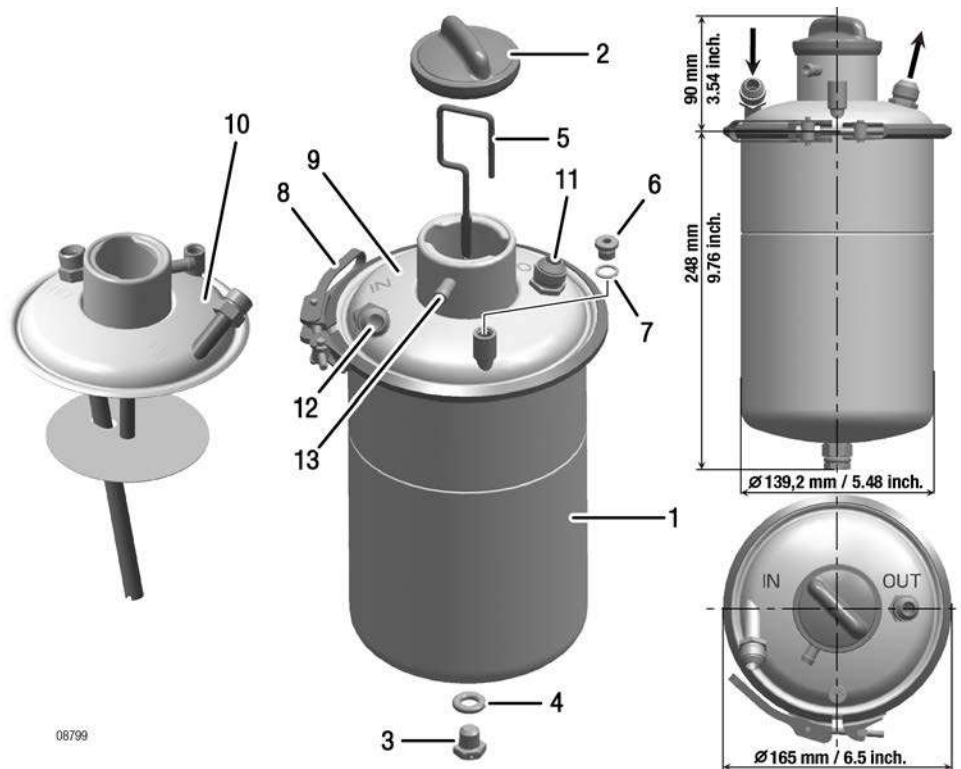

Figure 11.10: Oil tank

- | | |
|-------------------------------------|--|
| 1 Oil tank | 2 Bayonet cap |
| 3 Hex. screw M12x12 | 4 C12x18 gasket ring |
| 5 Oil dipstick | 6 M10x1 plug screw |
| 7 A10x14 gasket ring | 8 Profile clamp 163 |
| 9 Oil tank cover assy. (UNF 3/4-16) | 10 Oil tank cover assy. (metric M18x1.5) |
| 11 Oil outlet | 12 Oil feed line |
| 13 Vent nipple | |

BRP-Rotax
INSTALLATION MANUAL

CONNECTIONS FOR OIL CIRCUIT (ENGINE)

ATTENTION			
Engine damage may occur. If the lines are connected incorrectly, the engine will not be lubricated and it will be damaged very quickly.			

	Thread/ Outer dia.	Slip-on length	Tightening torque
UNF-thread optional (Screw connection) for oil feed line and outlet	3/4–16 UNF (AN-8)		25 Nm (18.5 ft.lb.)
Vent nipple (Metric)	8 mm (0.31 in.)	max. 15 mm (0.59 in.)	
Bent socket 90° optional with cap nut (M18x1,5)	12 mm (0.47 in.)	max. 24 mm (0.94 in.)	25 Nm (18.44 ft.lb.)
Nipple optional with cap nut / straight	12 mm (0.47 in.)	max. 24 mm (0.94 in.)	25 Nm (18.44 ft.lb.)

PERMISSIBLE POSITION AND LOCATION

⚠ WARNING
Non-compliance can result in serious injuries or death! At higher positioning of the oil tank, oil might leak through clearances at bearings back into crankcase. Oil tank will be empty and all oil will be in the crankcase. If fitted too low it might happen that the oil filter will be drained. In that case oil pressure will be too low for the first seconds after starting the engine.

BRP-Rotax INSTALLATION MANUAL

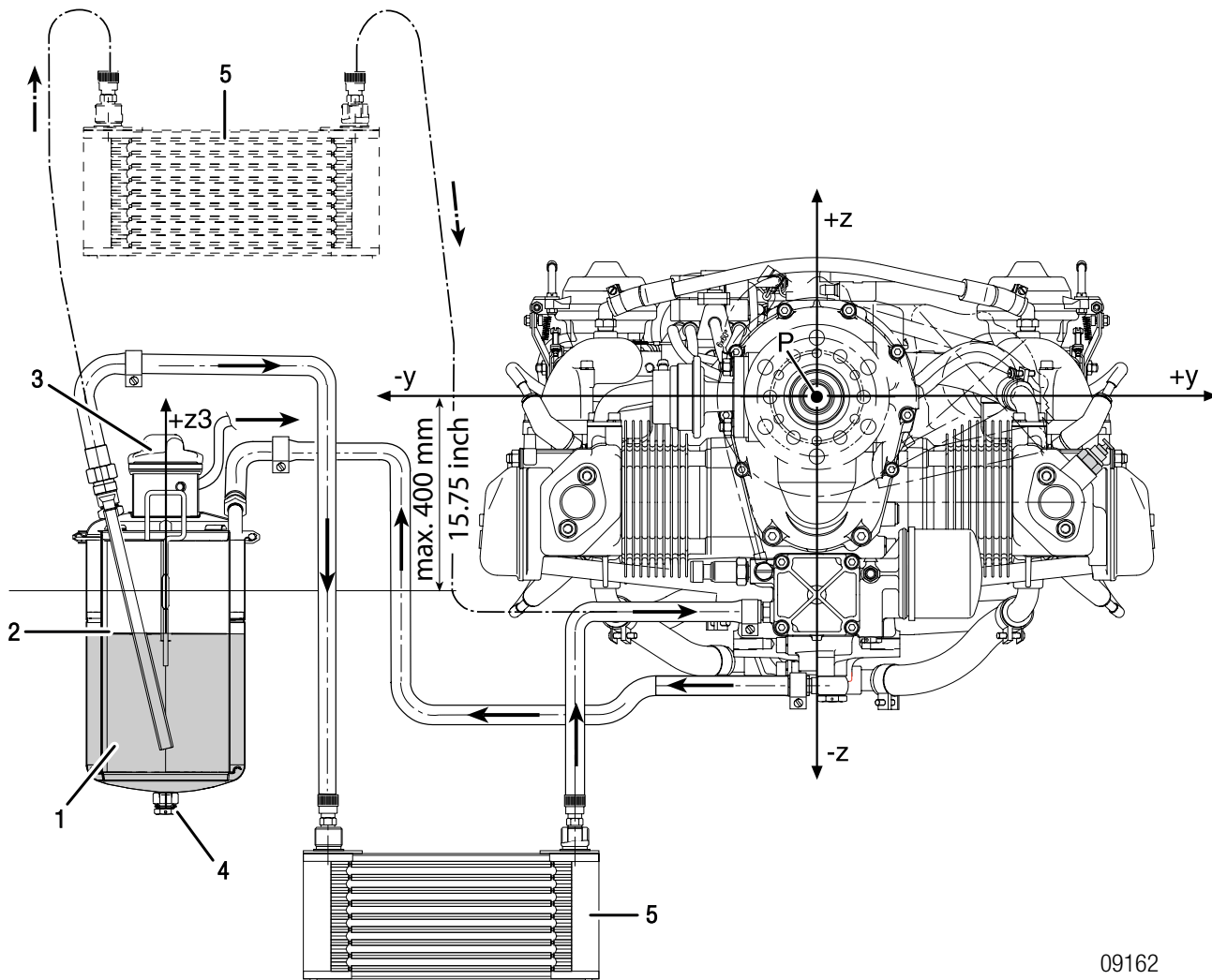

09162

Figure 11.11: Position and location of the oil tank

- | | |
|------------------|-------------------------------|
| 1 Oil tank | 2 Oil level |
| 3 Oil tank cover | 4 Oil drain screw, hex. screw |
| 5 Oil cooler | P Zero reference point |

- Longitudinal axis z3 must be parallel to z-axis of the system of coordinates.
The Permissible deviation from parallel: $\pm 10^\circ$

NOTE

This applies to both planes.

- The oil tank (1) has to be positioned such that the oil level (2) is always between 0 and -400 mm (-15.75 in.) on the z-axis.

BRP-Rotax

INSTALLATION MANUAL

NOTE

The profile clamp of oil tank should be between +40 mm (1.57 in) and -360 mm (-14.17 in.) on the z-axis.

- Install the oil tank free of vibrations and not directly on the engine.
- Bayonet cap and oil drain screw must be easily accessible.

CAPACITY

- Without oil cooler and connecting lines min. 3 l (0.8 US gal) depending on the respective installation.
- Volume of oil tank:
 - Up to the MIN. mark 2.5 l (0.66 US gal)
 - Up to the MAX. mark 3.0 l (0.79 US gal)
- Perform oil level check and add oil if necessary.

BRP-Rotax
INSTALLATION MANUAL

OIL RADIATOR (OPTIONAL)

Essential parts of the cooling system, such as radiator, etc., are available for this engine from BRP-Rotax. See also SI-PAC-014.

⚠ WARNING

Non-compliance can result in serious injuries or death!

The furnishing of proof in accordance to the latest FAR and EASA, has to be conducted by the aircraft manufacturer.

ATTENTION

The oil radiator must not restrict oil flow. Test system as per section “Checking the oil circuit”.

NOTE

Experience has shown that an oil radiator of at least 160 cm² (25 in²) is required, provided that airflow is adequate.

Weight

See [Chapter 72-00-00 section Weight](#).

PERMISSIBLE POSITION AND LOCATION

⚠ WARNING

Non-compliance can result in serious injuries or death!

The components must be designed and installed such that the permissible operating temperatures are maintained and the max. values are not exceeded. This must also apply to “Hot day conditions“!

The oil radiator should always be installed below the engine oil pump.

ATTENTION

Prevent unintentional draining of the oil radiator during longer periods of engine stop.

The oil radiator must be installed with the fittings pointing upwards i.e. in positive direction on the z-axis.

BRP-Rotax INSTALLATION MANUAL

VARIANTS OF CONNECTORS

General See the latest Illustrated Parts Catalog (IPC) of the respective engine type and Service Instruction SI-PAC-013.

BRP-Rotax
INSTALLATION MANUAL

REPLENISHING AND PURGING OF THE OIL SYSTEM

⚠ WARNING

Risk of burns and scalds. Hot engine parts.
Always allow engine to cool down to ambient temperature before starting work.

See also SI-912-018 "Purging of lubrication system for ROTAX® Engine Type 912 (Series), current issue.

NOTE

Perform oil level check and add oil if necessary. Verify that the oil tank is filled up to the maximum level (to the top of the flat portion of the dipstick). Additional oil (up to 0.5 liter (0.13 US gal)) may be added to the tank for the purpose of this procedure.

Work procedures

ATTENTION

Danger of severe engine damage.
Incorrectly connected oil lines to the oil tank or to the engine will result in severe engine damage.

1. Disconnect oil return line from the oil tank.
2. Place the free end of the return line into a suitable container below the engine.
3. Plug open connection on oil tank with suitable air tight cap.
4. Remove the spark plug connectors.
5. For easier rotation of engine remove one spark plug from each cylinder.

ATTENTION

Prevent any foreign objects entering through hole.

6. Using a compressed air line, pressurize the oil tank through its vent nipple connection (on the neck of the tank). Adjust the compressor outlet regulator so that the air line pressure is between 0.4 bar (5.8 psi) and 1 bar (14.5 psi). Do not exceed 1 bar (14.5 psi).

⚠ WARNING

Non-compliance can result in serious injuries or death!
Do not remove the oil tank cover before ensuring that air pressure has been completely released from the tank.

NOTE

The oil tank cover is not pressure-tight, some air can escape.

BRP-Rotax

INSTALLATION MANUAL

ATTENTION

The oil tank may empty and as a result introduce air into the oil system.
The pressure in the oil tank has to be maintained. Pay attention to the oil level and fill tank as required. Turn the engine by hand in direction of normal rotation until the first pressure indication appears on the oil pressure gauge. Do not use the starter.

7. Turn the engine by hand in direction of normal rotation until the **first pressure indication appears on the oil pressure gauge**. Normally this will take approx. 20 turns. Depending on installation it may take up to 60 turns.
8. Stop the pressurization.
9. Open the cap for the oil return line on the oil tank and reconnect the engine oil return line to the tank.
Ensure that the suction oil line and oil return lines are connected to the proper fittings on the oil tank.

ATTENTION

Carefully check all lubrication system connections, lines and clamps for leaks and tightness.

10. Re-fit the spark plugs. Restore aircraft to original operating condition.
11. Residual oil may have accumulated in the crankcase. Return it to the oil tank by following the oil level check procedure in the relevant Operators Manual.
12. Fill the oil in the tank up to the full mark on the dipstick.

ENVIRONMENTAL NOTE

Protect the environment.
Do not harm the environment by spilling oil. Dispose of oil in an environmentally friendly manner.

BRP-Rotax INSTALLATION MANUAL

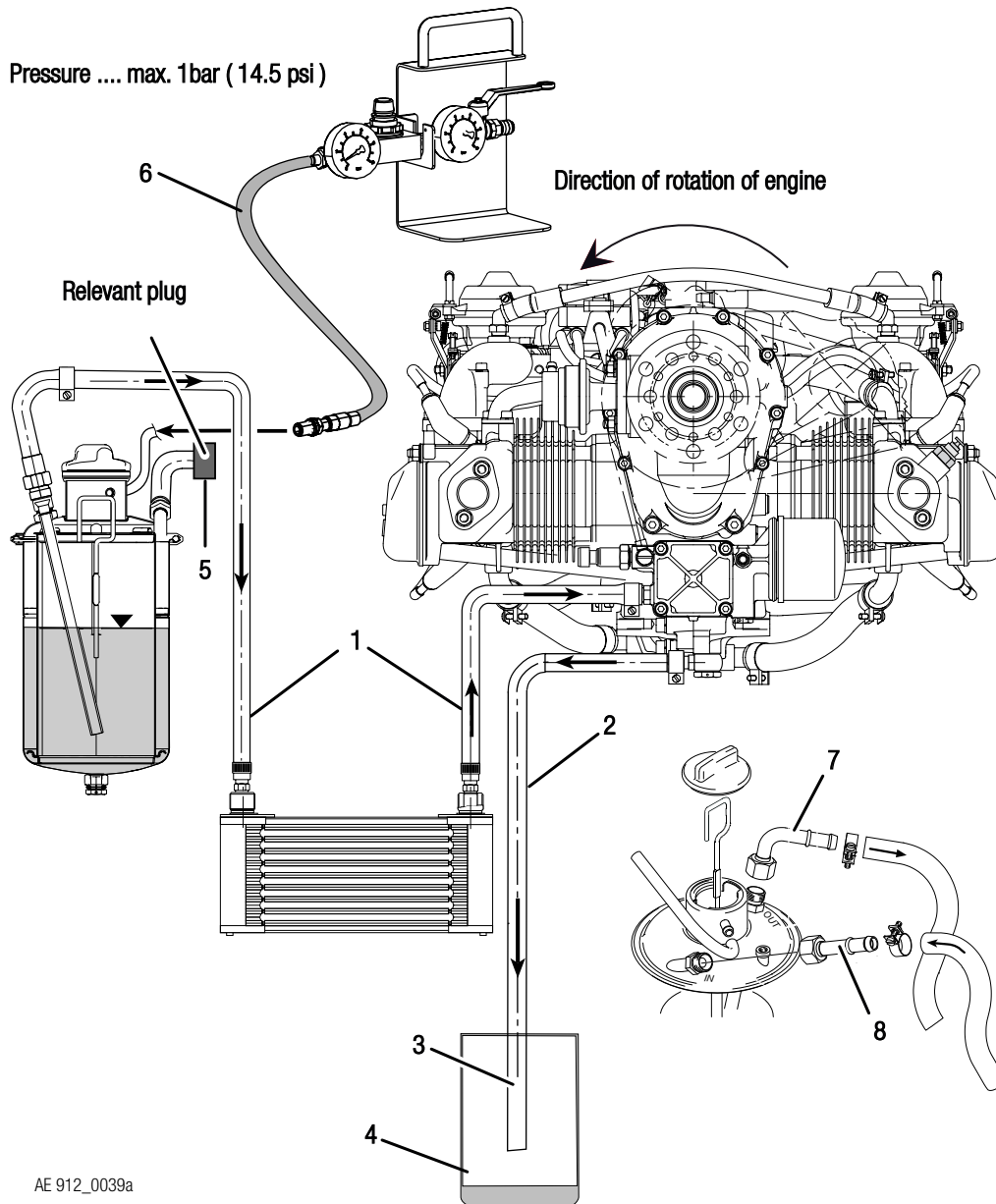

Figure 11.12: Purging the engine oil system

- | | |
|--|--|
| <p>1 Suction line</p> <p>3 Free end</p> <p>5 Plug</p> <p>7 To oil pump</p> | <p>2 Oil return line</p> <p>4 Tank</p> <p>6 Pressurized air connection</p> <p>8 Return from engine</p> |
|--|--|

BRP-Rotax INSTALLATION MANUAL

CHECKING THE HYDRAULIC VALVE TAPPET FOR CORRECT PURGING

⚠ WARNING

Risk of burns and scalds. Hot engine parts.
Always allow engine to cool down to ambient temperature before starting work.

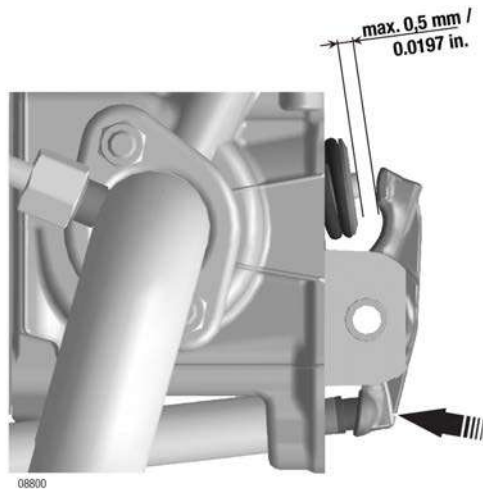

Figure 11.13: Hydraulic valve tappet

The following check procedure describes the correct method for purging the hydraulic valve tappet.

Instruction

The following work procedures must be carried out:

1. Remove valve cover on cylinder 1.
2. Turn crankshaft in direction of normal rotation so that cylinder 1 is set to top dead centre ignition (both valves are closed).
3. Push down the rocker arm on the push rod side with a force (F) of around 70 N (15.74 lb-force) for about 3 seconds.
You can use a fan belt tester, for example, to check approximately how much force is being exerted.
4. Check the size of the gap between the rocker arm and the valve contact surfaces.
Max. permitted gap 0.5 mm (0.02 in.).
5. Repeat on all other cylinders.

BRP-Rotax INSTALLATION MANUAL

ATTENTION

If it is possible to push the hydraulic valve tappet further than this limit, an additional engine run for about 5 min. at 3500 rpm, after refitting the valve covers, is required. In order to vent the hydraulic valve tappet, this process can be repeated another 2 times.

Replacement of components

If an hydraulic valve tappet still malfunctions after several engine runs, it must be replaced and the valve spring support must be inspected for wear.



All work must be performed in accordance with the relevant Maintenance Manual Heavy .

BRP-Rotax
INSTALLATION MANUAL

Chapter: 80-00-00
STARTING

TOPICS IN THIS CHAPTER

Interface overview2
Power supply wires from starter relay to the electric starter.....3
Starter relay assy. technical data4

BRP-Rotax
INSTALLATION MANUAL

INTERFACE OVERVIEW

⚠ WARNING

Non-compliance can result in serious injuries or death!

When working on the electric starter assy., there is a risk of short circuit and electrical fault. All installation work on the electric starter assy. must be carried out with engine switched off and the battery (negative terminal) disconnected. Ignition, main switches must be set to OFF.

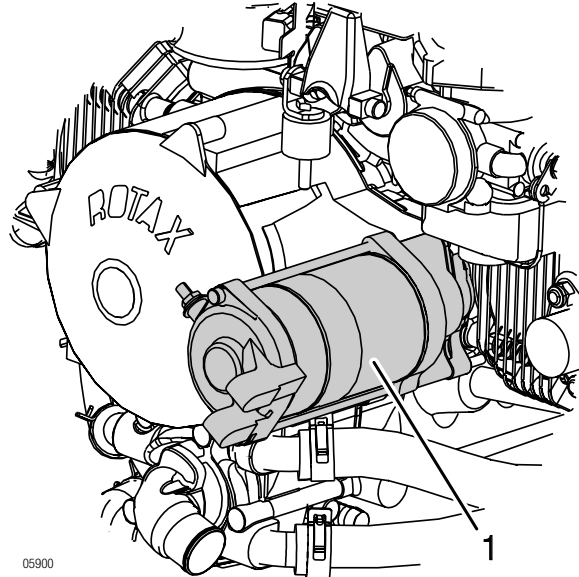

Figure 12.1: Electric starter

1 *Electric starter*

ATTENTION

Max. 80 °C (176 °F) ambient temperature by the electric starter housing. Activate starter for max. 10 sec. (without interruption), followed by a cooling period of 2 minutes.

BRP-Rotax
INSTALLATION MANUAL

POWER SUPPLY WIRES FROM STARTER RELAY TO THE ELECTRIC STARTER

Cross section	At least 16 mm ² (2.48 in ²)
Output	0.7 kW
Grounding cable	Grounding cable via engine block.
Positive terminal	M6 screw connection (tightening torque 4 Nm (36 in.lb)) suitable for cable terminals according to DIN 46225 (MILT7928; PIDG or equivalent).

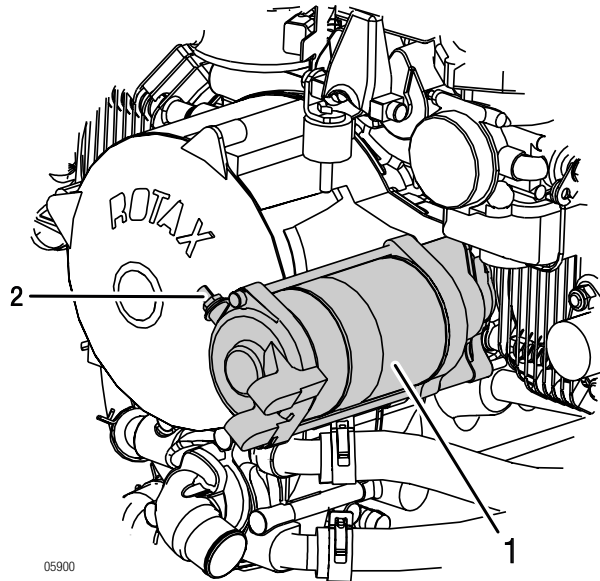

Figure 12.2: Positive terminal

1 *Electric starter*

2 *Positive terminal*

BRP-Rotax
INSTALLATION MANUAL

STARTER RELAY ASSY. TECHNICAL DATA

ATTENTION

Activation of starter relay limited to short duration. The duty cycle over an interval of 4 minutes is 25%.

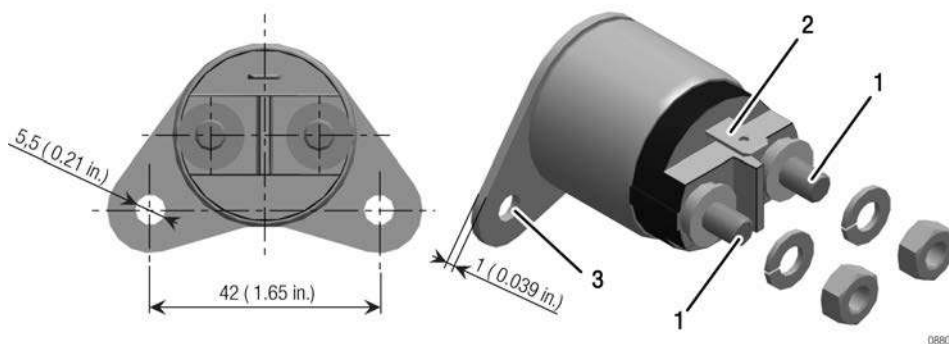

Figure 12.3: Starter relay

- 1 Main current connections
- 2 Control wiring
- 3 Ground

Nominal voltage	12 V/DC
Control voltage	min. 6 V / max. 18 V
Switching current	max. 75 A (permanent) max. 300 A/1 s (short duration)
Permissible ambient temperature	min. -40 °C (-40 °F) / max. +100 °C (212 °F)
Weight	See Chapter 72-00-00 section Weight
Main current connections	M6 screw connection (tightening torque 4 Nm (36 in.lb.)). suitable for cable terminals according to DIN 46225 (MIL-T-7928; PIDG or equivalent).
Control wiring	6.3x0.8 plug connector suitable for Faston connector (female) according to DIN 46247 (MIL-T-7928; (PIDG) or equivalent).
Grounding	Grounding cable via engine block.

BRP-Rotax

INSTALLATION MANUAL

Index

A

Abbreviations.....	6
Accessories, center of gravity.....	9
Air cooling interfaces.....	26
Air filter.....	7
Air intake system.....	2
Air intake system, Optional components.....	9
Air intake system, Requirements.....	4
Air intake system, System limits.....	2
Air temperature in the airbox.....	13
Airbox.....	8
Apparent perpendicular, Deviation.....	12
Approval EMC/EMI.....	3
Assembly flat pin terminal.....	11
Attaching the exhaust system.....	7

B

Battery.....	3
Bowden cable actuation, Requirements.....	21
Bowden cable actuation, Technical Data.....	19

C

Cable actuation, Connections.....	19
Cable actuation, Permissible load.....	19
Capacitor.....	18
Carburetor.....	15
Carburetor, requirements.....	15
Center of gravity.....	9
Checking the efficiency of the cooling system.....	8
Checking the oil circuit.....	7
Circuit wiring, Guidelines.....	2
Coarse filter.....	7
Conduit.....	2
Conversion table.....	11
Coolant capacity.....	21
Coolant exit temperature.....	4
Coolant hoses.....	14
Coolant temperature.....	4
Coolant type, Boiling point.....	5
Coolant types.....	5
Cooling system, Connecting size.....	15
Cooling system, general notes.....	20
Cooling system, Installation position.....	18
Cooling system, Operating limits.....	4, 12
Cooling system, Permissible location.....	18

Cooling system, Position of connection.....	15
Cooling system, System limitation.....	3
Crankcase pressure measurement.....	7
Cylinder designation.....	3

D

Deviation apparent perpendicular.....	12
Drainage line.....	13
Drainage lines, Airbox and drip trays.....	17
Drainage piping, Carburetor.....	18

E

Easy start function electronic module.....	9
Electric starter, Power supply wires.....	3
Electronic module.....	9
Engine installation, Preparations.....	2
Engine suspension.....	5
Engine suspension instructions.....	5
Engine views.....	3
Engine, Axes.....	3
Engine, center of gravity.....	9
Engine, Components.....	3
Engine, Handling.....	2
Engine, Installation dimensions.....	9
Engine, moments of inertia.....	10
Engine, Operating limits.....	11
Engine, Preservation.....	4
Engine, Storage.....	4
Engine, Technical data.....	8
Engine, Unpacking.....	2
Exhaust system, Notes.....	3
Exhaust system, optional components.....	10
Exhaust system, Requirements.....	5
Expansion tank, Installation position.....	18
External alternator.....	13

F

Filling and ventilation of the oil system.....	24
Fine filter.....	7
Fuel lines.....	6
Fuel manifold.....	11
Fuel pressure indicator.....	6
Fuel pump.....	9
Fuel pump, electrical.....	7

BRP-Rotax

INSTALLATION MANUAL

Fuel system, Requirements	5	Oil radiator, Permissible position and location	22
Fuel temperature	5	Oil radiator, Variants of connectors	23
G		Oil return	15
Gascolator	7	Oil system, Low ambient temperature	6
General	2	Oil tank	17
H		Oil tank, Capacity	21
Hydraulic governor for constant speed propeller	7	Oil tank, Connections	19
Hydraulic valve	27	Oil tank, Position and location	19
I		Oil thermostat	6
Ignition switches	10	Optional electric rev counter	16
Installation overview	19, 3, 2	Overflow bottle, Installation position	18
Installation position	5	Overflow bottle, optional	24
Instruction	15	Overview	2
Intake air ducting	6	P	
Interface description	2, 3	Permissible installation positions	9
interface overview	4	Propeller drive	2
Interface overview	4, 2	Propeller governor, hydraulic	7
Interface, Overview	2	Purging line, Requirements	11
Internal generator	5	R	
L		Radiator	22
Limits of operation	5	Radiator, Installation position	18
List of effective pages	1	Reading of EGT	9
M		Reading of EGT temperature	9
MAG switch	10	Rectifier regulator	6
Main oil pump, Connections	13	Rectifier regulator, integrated	14
Measuring of the vacuum	9	Rectifier regulator, requirements	7
Mechanical interfaces	6, 2	Rev counter	10
Mechanical rev counter	10	RTCA/DO-160C	3
Modification radiator installation	12	S	
Moments of inertia	10	Safety	12
Monitoring of the intake manifold pressure	11	Safety information	13
O		Scope of supply	4
Oil hose, Requirements	11	Select exhaust system	3
Oil inlet	13	Sensor for cylinder head temperature	2
Oil pressure sensor	7	Sensor for oil temperature	5
Oil radiator	22	Sensor, Coolant temperature (suffix -01)	3
		Starter relay, Technical data	4
		State of delivery	2
		System description	3
		System limitations	4

BRP-Rotax
INSTALLATION MANUAL

T

Table of amendments	1
Tach driver.....	10
Technical data.....	6
Technical documentation	16
Terms.....	6
Test run, Conduct.....	13
Throttle lever.....	22
Throttle lever for max. continuous power.....	13
Trial run.....	12
Trial run, Check.....	12
Type description 912 Series	3

V

Vacuum pump.....	5
Venting line, Requirements	12

W

Water trap.....	7
Weight.....	8
Wiring color codes.....	10

ROTAX®

Engine serial no.

Type of aircraft

Aircraft registration no.

Rotax® authorized distributor

FLYROTAX.COM

® and TM are trademarks of BRP-Rotax GmbH & Co KG.

© 2021 BRP-Rotax GmbH & Co KG. All rights reserved.

